

# Leeds Branch Dance 16 May 2015

Musician :David Oswald Duo MC: Claire Johnson

St Margaret's Church Hall,Horsforth, LS18 5LQ

## 1 THE HIGHLAND RAMBLER R40 · 3/4L

Roy Goldring: A Guide to Scottish Country Dancing · Crib: Eric Ferguson's SCD Cribs · Diagram: Keith Rose's Diagrams

- 1- 1c long cast to 2pl (2c up on [3-4] ; 1c+3c RHA (2,1,3)
- 9- 2c+1c LHA, 1W faces out ; 1W followed by 1M cast up round 2W and down the middle of set, 1W between 3c and 1M between 2c, all facing down
- 17- In lines of 3 down the middle (all swivel R) and up
- 25- 1M followed by 1W dance up, cast round 2W and into 2pl ; 1c turn RH
- 33- Circle6 and back

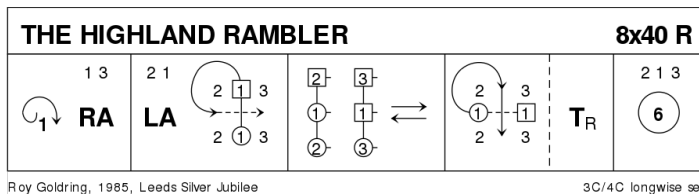

## 2 QUARRIES' JIG J32 · 3/4L

Kent W Smith: RSCDS XXXVI 3 · Crib: Eric Ferguson's SCD Cribs · Diagram: Keith Rose's Diagrams

- 1- 1c set | cast (2c up) ; ½ Fig8 Lsh round 1cnr (2,1x,3)
- 9- 1M+2c and 1W+3c Lsh Reels3 across, at end 1c LH turn to face 1cnrs
- 17- 1c+1cnrs change places RH while{2} 2cnrs set | centre dancers change places LH while{2} the others chase clw one position ; repeat from new positions
- 25- Repeat from new positions, but to finish 1c turn LH to 2pl ; 2c+1c+3c set | 1c cross RH.

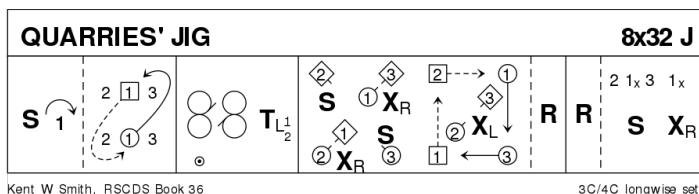

## 3 CITY OF BELFAST S32 · 3/3L

Lucy Mulholland: RSCDS XLVIII 6 · Crib: Eric Ferguson's SCD Cribs · Diagram: Keith Rose's Diagrams

- 1- 1c ½ Fig8 round 2c ; 1c turn 2c EH 1¼ into line across, 1c in the middle
- 9- 1c+2c Reel4, finish 2c in 1pl and 1c (last pass is Lsh) facing 1cnr
- 17- 1c set to 1cnr | set to 2cnr, dancing R into sideline (2,1x,3) ; All set | 1c cross RH
- 25- 1c+3c Espagnole (2,3,1)

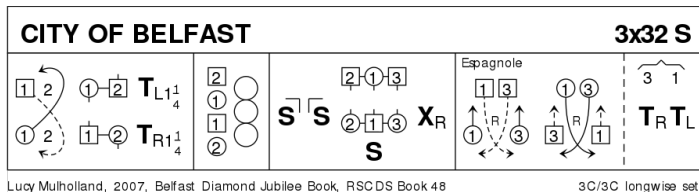

Espagnole: both W lead RHJ to M side, cross and cast back to exchanged places while Men cross to W side, lead RHJ back to M side crossing to exchanged places ; all turn P EH (2,1)

## 4 NEVER AT SEA R48 · 6/6L

J C Haddow · Crib: Eric Ferguson's SCD Cribs · Diagram: Keith Rose's Diagrams

On second chord, the bottom three couples cross to opposite side (1,2,3,4x,5x,6x)

This dance is centro-symmetric; both ends do identical figures

- 1- 1c+6c cross RH | cast inwards (2c+5c to end) ; cross LH | cast to middle (3c+4c to end) (2,3,1,6x,4x,5x)
- 9- 1M+6W & 6M+1W take promhold Lsh Reels3 across with 4c/3c resp. (2,3,1,6x,4x,5x)
- 17- 2c+3c+1c & 5c+4c+5c mirror Reels3 on the sides, 1c&6c start inwards towards own end (2,3,1,6x,4x,5x)
- 25- 1c+6c R&L
- 33- 2c&5c cross RH while{ } 3c+1c & 6c+4c ½ RHA | on sidelines change place LH between 1pl/2pl, 3pl/4pl and 5pl/6pl (1x,2x,4,3x,5,6) ; repeat {4}
- 41- repeat [33-36] ; All turn P RH (5,4,6,1,3,2)

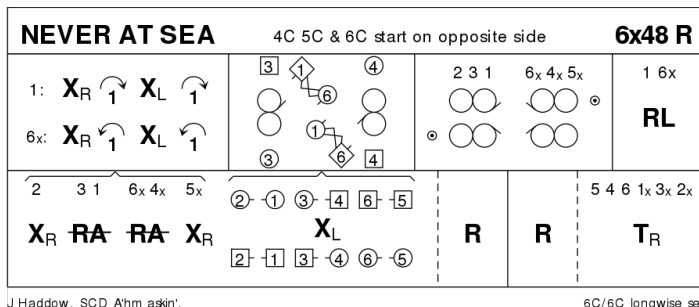

Dance 3 times to end 6 5 4 3 2 1 or 6 times to end 1 2 3 4 5 6

**5 NAPIER'S INDEX J40 · 3/4L**

Brian Charlton: RSCDS XLV 8 · Crib: Eric Ferguson's SCD Cribs · Diagram: Keith Rose's Diagrams

- 1- 1c set | cast off ; turn LH 1¼ into
- 9- 1c+1cnr BiL | 1c+1cnr turn RH {4} | repeat BiL
- 17- 1c+cnrs Reels3 on the sides, Lsh to 2cnr, 1c finish LHJ and RHJ with 2cnr
- 25- 1c+2cnr repeat [9-16]
- 33- Reels3 across, 1c Lsh to 3c, at end 1c cross RH as 2c+3c curve into place (2,1,3)

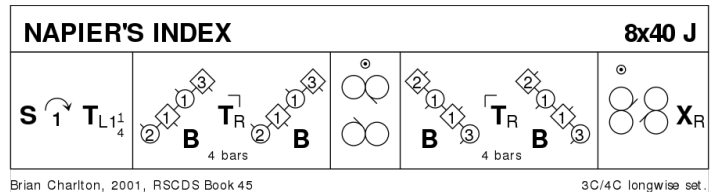

**6 THE SWAN AND THE TAY S32 · 3/3L**

Audrey Saunders: RSCDS Leaflets 2014 56 · Crib: Eric Ferguson's SCD Cribs · Diagram: Keith Rose's Diagrams

- 1- 1c (in and down) Fig8 on own sides (give hands) (1,2,3)
- 9- 1c cross into Reels3{6} on opp. sides | 2c dance up as 1c face 1cnr
- 17- 1c+cnrs Pass&Turn, pass Rsh ; repeat with 2cnr, finish (2,1,3)
- 25- All set | cross RH ; chase ½ clw to (3,1,2)

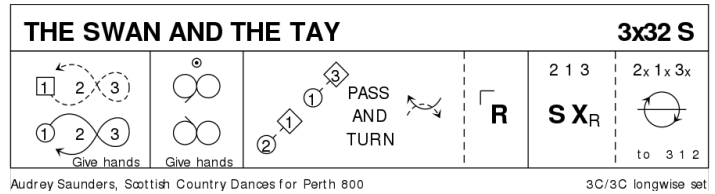

**7 SCOTT MEIKLE R32 · 4/4L**

Alice McLean: RSCDS XLVI 3 · Crib: Eric Ferguson's SCD Cribs · Diagram: Keith Rose's Diagrams

- 1- 1c cross RH | cast (2c up) ; ½ Fig8 up (2,1,3,4)
- 9- 1c+3c RHA, LHA (2,1,3,4)
- 17- Lsh opposing Reels3 across: (1W+3W behind dancing as one) with 2c and (3M+1M behind) with 4c (to 2,3,1,4)
- 25- 1c+4c ½ R&L ; turn RH 1½ (2,3,4,1)

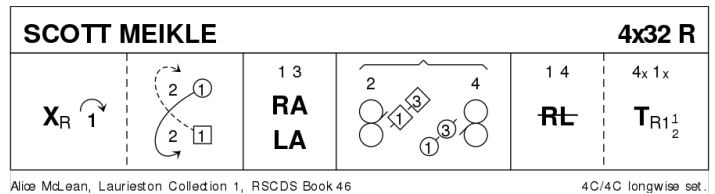

**8 RED RUM J32 · 3/4L**

Stephen Brown: The Ribble Valley Book of Scottish Country Dances · Crib: MiniCribs · Diagram: Keith Rose's Diagrams

- 1-8 1s set & cross RH, 1s set to 2s on sides & 1/2 turn LH
- 9-16 1s+2s dance Ladies Chain & end with 1s facing 1st corners
- 17-24 1s set to 1st corners & turn 2H, 1s set to 2nd corners & turn 2H
- 25-32 1s dance reels of 3 on opposite sides giving LSh to 1st corner cross to 2nd place own sides

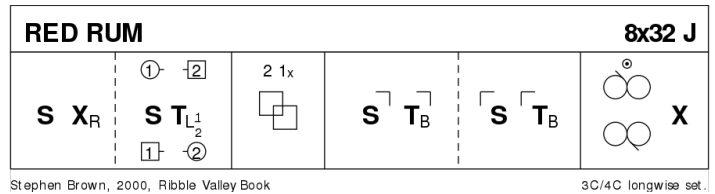

**9 PROGRAMME ITEM – Interval**

**10 THE MONTGOMERIES' RANT R32 · 3/4L**

Castle Menzies (18C): RSCDS X 1 · Crib: Eric Ferguson's SCD Cribs · Diagram: Keith Rose's Diagrams

- 1- 1c cross RH | cast off (2c up) ; cross LH | cast L (W up, M down)
- 9- 2c+1W & 1M+3c Rsh Reels3 across
- 17- 1c NHJ set to 2W (swivel ½ inwards), set to 3M (veer L together), set to 3W (swivel ½ inwards), set to 2M (and face own 2cnr)
- 25- Reels3{6} on the sides, Rsh to 2cnr | 1c cross RH to 2pl

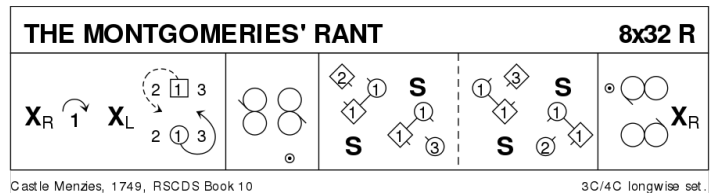

# 11 THE VALENTINE S32 · 3/4L

Linda C Gaul: Magazine Dances 2005-2009 · Crib: Eric Ferguson's SCD Cribs · Diagram: Keith Rose's Diagrams

- 1- 1c set | Turn BH and face down, NHJ ; dance to bottom and cast up (2c up) to (2,1,3)
- 9- 2c+1c DblFig8 (1c cross up), 1c finish facing 1cnr
- 17-20 1c+1cnrs set **while**{2} 2cnrs set diagonally | 1c dance round P by the R to face 1cnr position **while**{2} cnrs chase 1 place clw ;
- 21-24 1c+2cnrs set **while**{2} 1cnrs set diagonally | 1c dance round P by the R to 2plx **while**{2} cnrs chase 1 place clw (3x,1x,2x)
- 25- All C turn RH ½ and stay in middle facing P | set to P (join H) and face up NHJ ; all C dance to top, casting off or looping into (2,1,3)

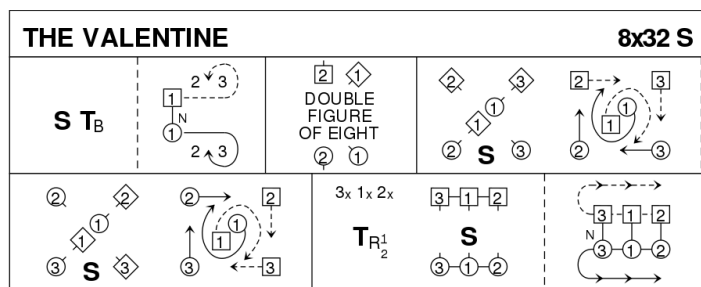

Linda Gaul, RSCDS 5/2009

3C/4C longwise set.

# 12 POLHARROW BURN R32 · 5/5L

Hugh Foss: Magazine Dances 2005-2009 · Crib: Eric Ferguson's SCD Cribs · Diagram: Keith Rose's Diagrams

- 1- 1c+3c cross | cast off (2c+4c up) ; ½ Fig8 up round 2c/4c (2,1,4,3,5)
- 9- 1c+3c turn P RH ; turn P LH to face 1cnrs **while**{8} 2c+5c cross RH and chase clw. to other end of set (2M & 5W leading P) (5,1,4,3,2)
- 17- diag. ½Reels4 with 1cnrs (1diags.) (pass Lsh) ; repeat on 2diags.
- 25- Repeat with 3cnrs (1diags) ; 1c+3c turn LH and cast off on own side (4c+5c up) (2,4,1,5,3)

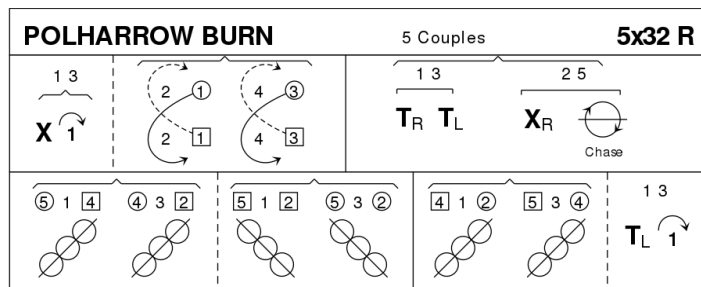

Hugh Foss, 1967, Glendarrloch S D Sheets, www.dancearchives.co.uk

5C/5C longwise set.

# 13 TRIBUTE TO THE BORDERS J32 · 3/4L

Roy Goldring: RSCDS Leaflets 2014 15 · Crib: Eric Ferguson's SCD Cribs · Diagram: Keith Rose's Diagrams

- 1- 1c cross RH | cast (2c up) ; turn 1¼ RH to promhold facing M side
- 9- 1c Rsh ½Reel3 with 2M+3M ; Rsh ½Reel3 with 3W+2W, 1c finish in centre facing 3W (now in 1W pl)
- 17- 1c set to 3W pulling Rsh back | set to 2W ; set to 2M | 1c set to 3M **while**{2} 3c+2c set advancing into
- 25- 3c+1c+2c Allemande

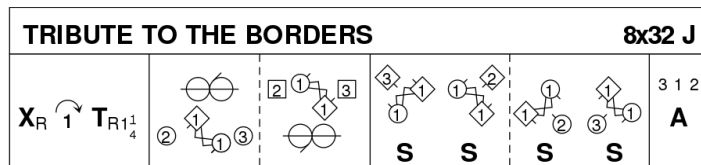

Roy Goldring, 1979, RSCDS Leaflet 11

3C/4C longwise set.

# 14 PEGGY'S STRATHSPEY S32 · 3/4L

Eric Finlay: RSCDS XLI 5 · Crib: Eric Ferguson's SCD Cribs · Diagram: Keith Rose's Diagrams

- 1- 1c cross down RH **while**{2} 2c cast up and 3c set | Mirror Reels3{6} on sidelines, 1c starting out and down (to 2,1x,3)
- 9- 3c cross up LH **while**{2} 1c cast off & 2c set | Mirror Reels3{6} on sidelines, 3c starting out and up (to 2,3x,1x)
- 17- 3c+1c ½ R&L ; 2c+1c ½ R&L (to 1x,2x,3)
- 25- 1c+2c Reversed Espagnole :[1M+2M lead RHJ to M side crossing 2M in front and cast back to exchanged places **while**{2} 1W+2W cross to W side, cast in and lead RHJ to M side crossing 2W in front, to exchanged places ; both C turn P EH 1½] (to 2,1,3)

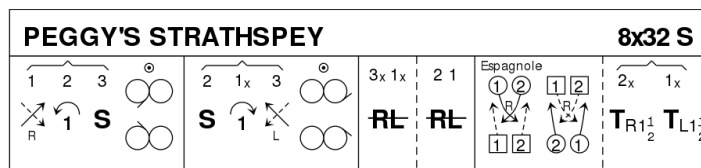

Eric Finlay, RSCDS Book 41

3C/4C longwise set.

For [16] Finley's original version says »... third couple ... in 2nd place on the opposite side, "having danced the long way into place", a phrase omitted in the RSCDS version.

# 15 THE MEETING OF THE WATERS R48 · 3/4L

Iain Boyd: The Strathtay Album · Crib: Eric Ferguson's SCD Cribs · Diagram: Keith Rose's Diagrams

- 1- 1c+2c Reel4 across, 1M+2W pass Lsh as 1W/2M cast down/up, finish in places
- 9- 1c parallel Rsh Fig8 on own side round 2c+3c
- 17- 1W, followed by 1M, cast off behind 2W, cross down between 3c (2c up), cast up round 3M, (to 2,1,3)
- 25- 1c+3c RHA ; 2c+1c LHA
- 33- 2c+1c+3c parallel Reels3 on the sides (1c Rsh to 3c)
- 41- All Circle6 and back

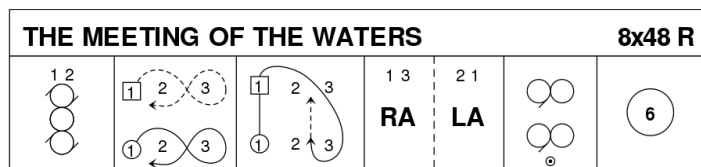

Iain Boyd, Strathtay Album

3C/4C longwise set.

**16 MACLEOD'S FANCY** J32 · 4/4L

John Drewry: RSCDS XXXIII 3 · Crib: Eric Ferguson's SCD Cribs · Diagram: Keith Rose's Diagrams

- 1- 1c+4c set facing diagonally | 1W+4M cast R round own sideline and meet with ¼ RH turn in the middle, to places **while{6}** 1M+4W make that turn and cast R round own sideline to places
- 9- All dance Reels4 on the sides to finish (1,2,3,4) facing up/dn
- 17- Middles (2c+3c) turn ends RH ½ way to form a St Andrew's Cross (1c+4c retain RH and give LHA in the middle) | all set ; continue turns once round RH, at the end 1c+4c pass Rsh on own side to end (2,4,1,3) (1M+4W with polite turn)
- 25- (Middle couples solo:) 4c+1c set, Women cross NHJ and face ends **while{2}** Men cross over outside them and turn inwards to join P ; 4c(1c) lead up RH (lead down LH) between 2c(3c), cross and cast to 2pl(3pl) (2,4,1,3)

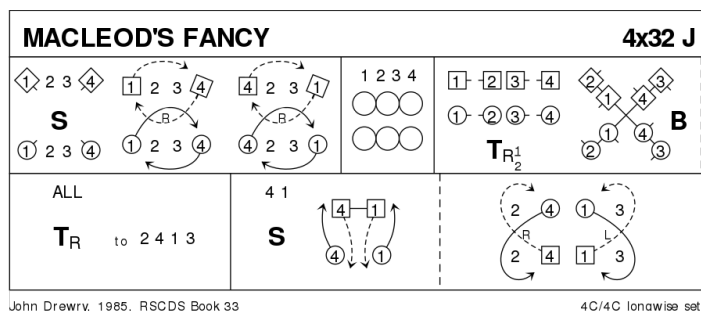

John Drewry, 1985, RSCDS Book 33

4C/4C longwise set.

**17 THE IRISH ROVER** R32 · 3/4L

James B Cosh: Twenty Two SCD and Two Others · Crib: Eric Ferguson's SCD Cribs · Diagram: Keith Rose's Diagrams

- 1- 1c lead through 3c (2c up) and cast up ; 1M+3c and 1W+2c RHA, finish facing 1cnrs.
- 9- 1c+1cnrs ½Reel4, pass Lsh ; ½Reel4 with 2cnrs, fast ½ LH turn in the centre
- 17- 1W+3c (at top) & 1M+2c Reels3 across (Lsh to 1cnp pos), (to 3x,1,2x)
- 25- diagonal R&L (1M down,1W up) (2,1,3)

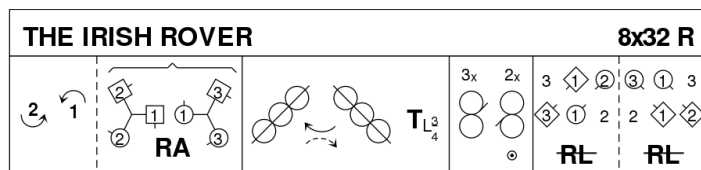

James B Cosh, 22 SCD & 1 other

3C/4C longwise set

**18 PROGRAMME ITEM – Extras**

**19 THE ROYAL DEESIDE RAILWAY** R32 · 3/4L

Ron Arrowsmith: RSCDS XL 9 · Crib: Eric Ferguson's SCD Cribs · Diagram: Keith Rose's Diagrams

- 1- 1c (no hands) dance down cross below 3c and (2c up) cast up to 2W ; 1c (1W leads)+2W RHA
- 9- 1c+2M LHA, finish facing up, 1M behind 1W ; dance up and cast off on own side to 3M
- 17- 1c+3M RHA ; 1c+3W LHA, 1c finish facing down, 1W leading
- 25- 1c dance down between 3c, cast up on own side to 2pl ; 2c+1c+3c turn RH

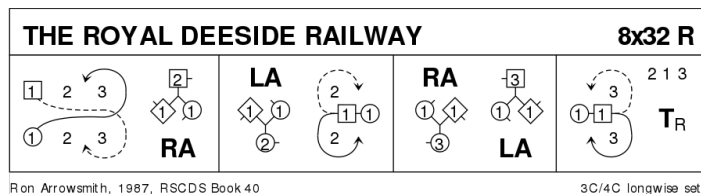

Ron Arrowsmith, 1987, RSCDS Book 40

3C/4C longwise set.

after 2nd turn new 3c step up on [1-2]

**20 THE FLIGHT OF THE FALCON** J32 · 3/4L

Barry Priddey: Anniversary Tensome · Crib: Eric Ferguson's SCD Cribs · Diagram: Keith Rose's Diagrams

- 1- 1c set and cast off one (2c up), 1¼ turn LH so 1M (with 1W behind) faces 3W
- 9- 1c lead-change diagonal Reel3 with 1cnrs (Rsh to 3W) (1M & 1W switch lead at each end of the reel), end facing 3M
- 17- Repeat with 2cnrs (start Rsh to 3M), finish facing 1cnrs
- 25- Turn 1cnp RH, pass P Rsh, repeat with 2cnp, cross to (2,1,3) (cnrs turn for 4 bars)

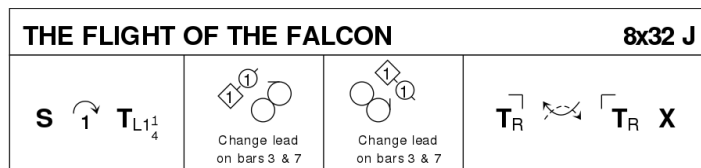

Barry Priddey, Anniversary Tensome

3C/4C longwise set

**21 CHERRYBANK GARDENS S32 · 3/3L**

*John Drewry: Bankhead Book Part 1 · Crib: Eric Ferguson's SCD Cribbs · Diagram: Keith Rose's Diagrams*

- 1- 1c+2c set | petronella in tandem ; repeat (2x,1x,3)
- 9- 2c+1c set | 2c cross RH **while(2)** 1c cross LH ;  
1W+2c & 1M+3c RHA (Teapots) to sidelines (2,1,3)
- 17- 1c+3c S&Link ; 3c+1c circle4 left, end 3c facing 1c for
- 25- G-Chain (2c cross to start) (2, 3, 1)

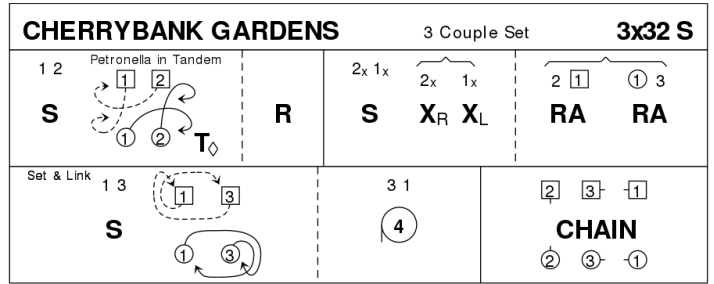

John Drewry, 1991, Bankhead 1

3C/3C longwise set..