

Leeds Branch Dance 17th June 2017

Corpus Christi Catholic College Neville Road, Halton Moor, Leeds LS9 0TT

Music: David Oswald Trio MC: Helen Freer

1 MAIRI'S WEDDING R40 · 3/4L

James B Cosh: *Twenty Two SCD · Crib*; Eric Ferguson's *SCD Crib*s · Diagram: Keith Rose's *Diagrams*

- 1– 1c turn RH | cast (2c up) ; turn LH to face 1cnrs
- 9– 1c ½ Reel4 with 1cnrs (pass P Lsh) ; Repeat with 2cnrs
- 17– Repeat with 3cnrs (1cnr person) ; Repeat with 4cnrs (2cnr person)
- 25– 1W+2c & 1M+3c Reels3 across, Lsh to 1cnr
- 33– 2c+1c+3c circle6 and back

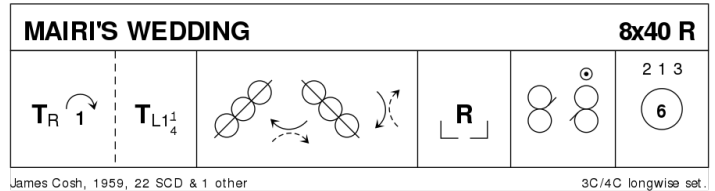

Note: Cosh explicitly tells 1c to pass Lsh in [9-24]; however the Rsh pass is quite common, and nicknamed »Mairi's Divorce«.

2 THE SINGING SANDS S32 · 3/3L

Barry Priddey: *The Silver Rose Book of Scottish Country Dances · Crib*; Eric Ferguson's *SCD Crib*s · Diagram: Keith Rose's *Diagrams*

- 1– 1c+2c Tourbillon (1c+2c turn P BH ½, opening out to one place clw in the square (1c to W side, 2c to M side) | 1c set to 2c ; repeat figure (to 2x,1x) | 2c+1c cross RH) (2,1,3)
- 9– 1c (M up, W down) dances ½ Fig8 Rsh round 2cnr ; 1M+3c & 1W+2c ½ Rsh reels3 across (2x,1,3x)
- 17– Diagonal R&L (to 3,1,2)
- 25– All set | 3c+1c ½ RHA **while** } 2c cross RH ; all chase clw ½ round (2,3,1)

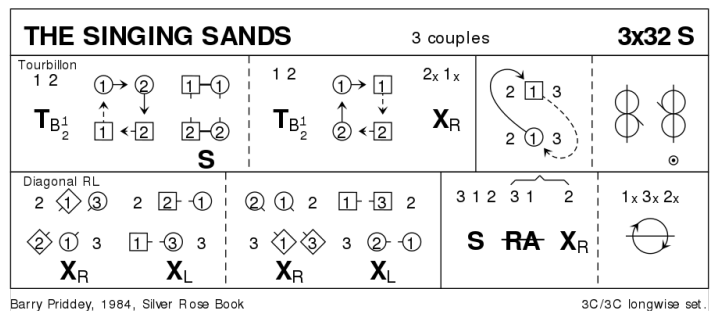

Note: The dry white sands on the north-west side of the Isle of Eigg are said to produce a musical sound when walked upon.

3 FOLLOW ME HOME J32 · 3/4L

Ellie Briscoe: RSCDS XXXVIII 3 · Crib: Eric Ferguson's SCD Cribbs · Diagram: Keith Rose's Diagrams

- 1- 1c set | cross RH ; cast off (2c up) | turn $\frac{3}{4}$ LH
- 9- BiL with 1cnrs, $\frac{1}{2}$ turn 1cnrs RH ; 1c followed by 1cnrs chase clw round 4cnry to leave 1cnrs in exchanged places, and join LH to 2cnr, RH to P
- 17- BiL with 2cnrs ; $\frac{1}{2}$ turn 2cnrs LH ; 1c followed by 2cnrs chase cclw, 1c crossing Lsh to 2plx facing out (3x,1x,2x)
- 25- $\frac{1}{2}$ Lsh Reels3 on the sidelines, All set and cross (2,1,3)

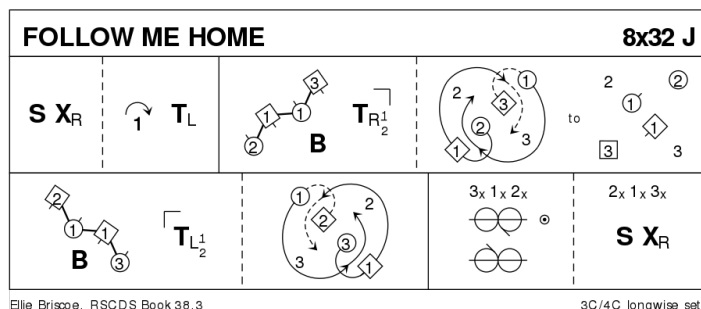

4 JOHN OF BON ACCORD R32 · 3/4L

Roy Goldring: RSCDS XXXIII 5 · Crib: Eric Ferguson's SCD Cribbs · Diagram: Keith Rose's Diagrams

- 1-16 4 progressive $\frac{1}{2}$ Reels3 across, as follows: 1c+2W (1c start Rsh) ; 1c+2M (start Lsh) ; 1c+3W (Rsh) ; 1c+3M (Lsh), 1c finish in 3pl a bit in from the sidelines (2c & 3c finish their reels in 1plx and 2plx)
- 17- 1c turn RH, cast up one place on own sides (3c down) ; 1c $\frac{1}{2}$ Fig8 round 2c (2x,1x,3x)
- 25- All turn P $\frac{3}{4}$ RH to face P along the midline | All Set retaining RHJ ; all turn P $\frac{3}{4}$ RH (to 2,1,3) | All Set.

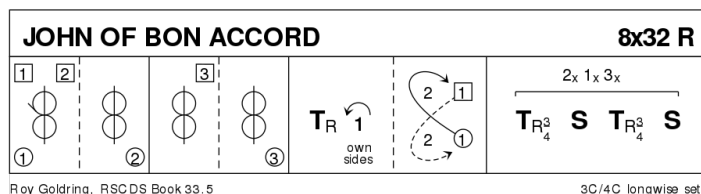

5 THE GENTLEMAN S32 · 3/4L

Roz Scott Huxley: RSCDS XXXV 5 · Crib: Eric Ferguson's SCD Cribbs · Diagram: Keith Rose's Diagrams

- 1- 2c step up as 1c turn BH to face P between them in line4 across | 1c+2c set, 1c advancing and passing on the second step ; $\frac{1}{2}$ Reel4, at end 1c pass LH to face down NHJ
- 9- 1c dance down to face P between 3c, repeat set and $\frac{1}{2}$ Reel4 with 3c, finish between 3c on own side LHJ
- 17- 1c lead to top, cross and cast to 2plx ; $\frac{1}{2}$ Reels3 across, Rsh to 4cnr (W up, M dn) (to 2,1,3)
- 25- 2c+1c Poussette.

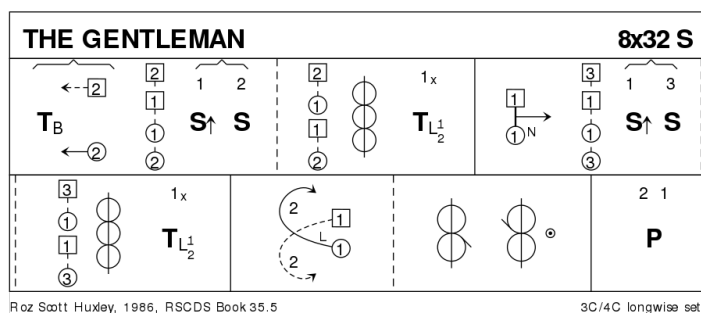

11 THE COOPER'S WIFE J40 · 3/4L

John W Mitchell: *Whetherly Book 16* · Crib: Eric Ferguson's *SCD Cribbs* · Diagram: Keith Rose's *Diagrams*

- 1-10 1c cast off one | full Fig8 around 2c & face 1cnrs (2c up [9-10])
- 11-20 1c+1cnr turn RH ½ | 1c dance ½ way clw round the set **while{4}** 1cnr turn LH 1½ | 1c+1cnr turn RH ½ | 1c turn LH ¾ to face 2cnrs. (Corners' Chain)
- 21-30 1c & 2cnrs repeat 11-20. 1c face 3cnr position.
- 31-40 1c ½Reel4 with 1cnrs & pass Lsh to face 4cnr pos ; 1c ½Reel4 with 2cnrs | 1c turn LH to 2pl, facing out to repeat (2,1,3)

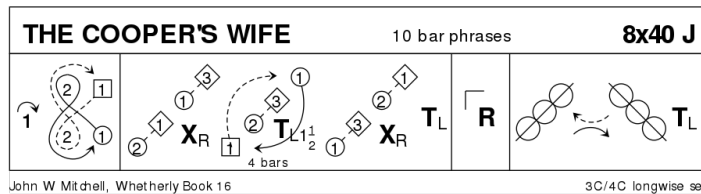

After 2nd turn the old 1c casts to 4pl on the new [1-2]

12 GANG THE SAME GATE S32 · 3/4L

Milton Levy: *RSCDS XXXVI 4* · Crib: Eric Ferguson's *SCD Cribbs* · Diagram: Keith Rose's *Diagrams*

- 1- 1c cross RH | cast off 2 (2c+3c up) ; 1c cross RH and cast up (3c down) to (2,1,3)
- 9- 1c set passing Lsh | turn 1cnrs BH ; ½Reel4 with 2cnrs, at end 1c curve R to between end cpl (M above facing W below)
- 17- 1c set passing Lsh, turn 4cnr (2cnr persons) BH ; ½Reel4 with 1cnrs, at end curve R to (3x,1x,2x)
- 25- All S&Link3 ; repeat (2,1,3)

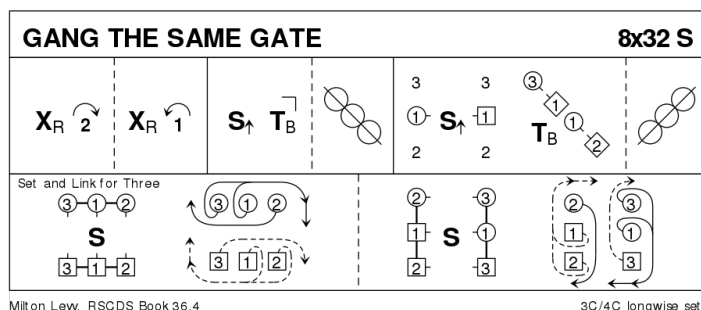

13 NOTTINGHAM LACE R96 · 4S

Jenny Bradley: *Nottingham Lace* · Crib: Eric Ferguson's *SCD Cribbs* · Diagram: Keith Rose's *Diagrams*

- 1- Half G-Chain ; all set to P | turn ¾ RH
- 9- All W ½LHA **while{2}** M dance clw one place | all turn new P RH ½ ; repeat (M ½LHA, W ¼ clw)
- 17- Repeat [9-16] to original places
- 25- 1c+3c dance in, change places RH, split and cast behind side C, pass RH to own place, forming a longwise set | All set
- 33- All A&R ; 1c+2W+4M & +3c+2M+4W, circle4 L and open into lines of 4 across with 1c & 3c in the middle
- 41- All A&R ; circle8 half way, finishing in square set opposite original places
- 49-72 Repeat [25-48] with 2c+4c as dancing couples
- 73-96 Repeat [1-24]

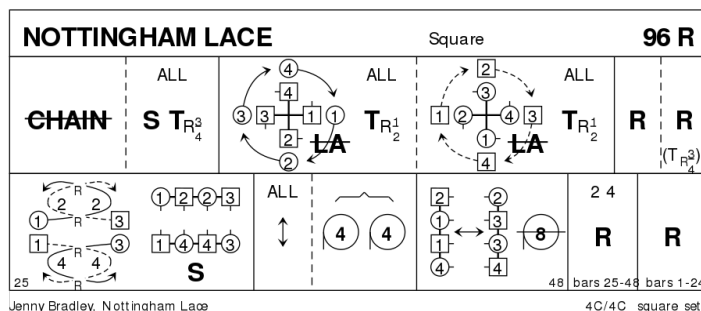

14 THE CHEQUERED COURT J32 · 3/4L

Duncan Brown: RSCDS XLII 3 · Crib: Eric Ferguson's SCD Cribbs · Diagram: Keith Rose's Diagrams

- 1- 1c cross RH | cast off (2c up) ; ½ Fig8 across to the R (1M up, 1W down) to face 1cnr
- 9- 1c+1cnrs pass and turn, at end 1c swivels R to be BtoB facing 4cnr ; 1c+4cnrs pass and turn, 1c swivels R to finish BtoB facing own side for
- 17- DTr, 1c finish between end couple facing own side
- 25- Reels3{6} across (Rsh to 4cnr) | 1c cross RH (2,1,3)

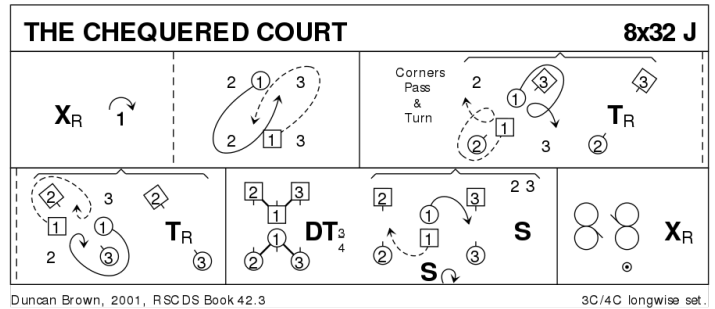

15 ALLTSHELLACH S32 · 2/4L

Elizabeth D Gilroy: RSCDS XXIII 2 · Crib: Eric Ferguson's SCD Cribbs · Diagram: Keith Rose's Diagrams

- 1- 1c+2c set | turn BH, into ; 1c+2c ½Poussette, finishing in the middle, facing down
- 9- 2c+1c lead down the middle ; (2c divides) 1c+2c lead up to (1,2)
- 17- Reel4 across the dance, 1W and 2M pass Lsh to begin, and finish with a loop on own side
- 25- Tournée

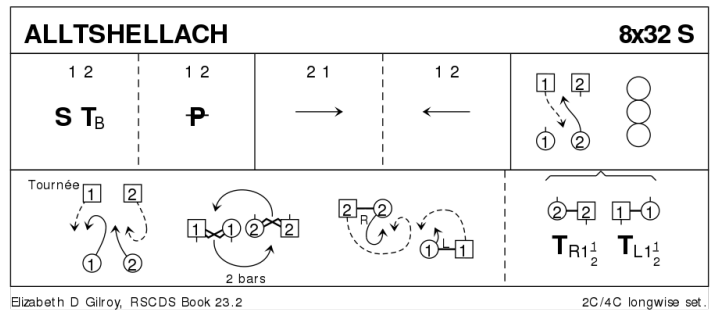

16 THE REEL OF THE ROYAL SCOTS R32 · 3/4L

Roy Goldring: The Leaflet Dances with Music · Crib: Eric Ferguson's SCD Cribbs · Diagram: Keith Rose's Diagrams

- 1- 1W+2W (1M+2M) turn LH (RH) ½, finishing 1c BtoB in 2pl | All set as in DTr ; 1W+3W (1M+3M) turn RH (LH) ½ | 2c+3c+1c set as in DTr
- 9- 1c followed by 3c dance up between 2c, cast off ; dance NHJ down through 3pl, cast up to face 1cnrs, 3c looping into 3pl
- 17- 1c turn 1cnrs RH, pass Rsh (cnrs dance for {4}) ; turn 2cnrs RH (same), and cross Rsh to (2,1,3)
- 25- All circle6 and back

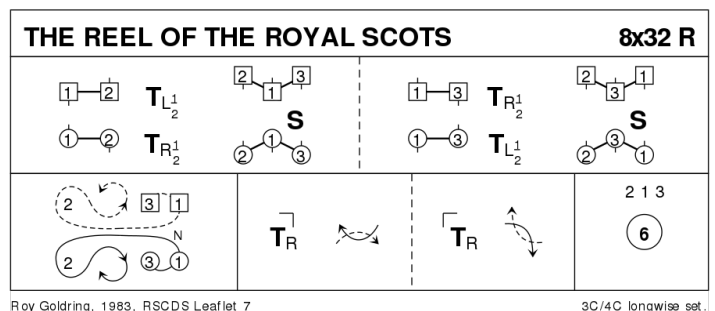

17 THE LAIRD OF MILTON'S DAUGHTER

J32 · 3/4L

Craigmyle: RSCDS XXII 10 · Crib: Eric Ferguson's SCD Cribs · Diagram: Keith Rose's Diagrams

- 1- 1c set, cross RH ; cast off (2c up), turn LH to 1cnrs
- 9- Corners' chain: 1c+1cnrs turn ½ RH | 1cnrs turn LH ; 1c+1cnrs turn back RH ½ | 1c turn LH 1¼ to 2cnrs
- 17- Repeat with 2cnrs, 1c crossing LH to 2pl
- 25- 2c+1c+3c circle6 and back

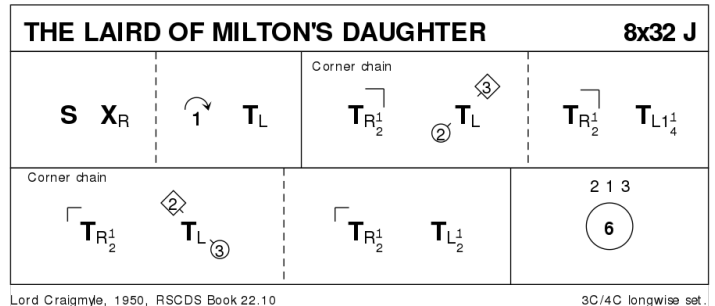

18 EXTRAS

19 BLOOMS OF BON ACCORD

R32 · 4/4L

John Drewry: Deeside Book Part 2 · Crib: Eric Ferguson's SCD Cribs · Diagram: Keith Rose's Diagrams

3c+4c cross on 2nd chord(1,2,3x,4x). This dance has top/bottom symmetry

- 1- All C set | 1c+2c & 3c+4c RHA | 1c & 4c cast in to 2pl/3pl **while**{2} 2c+3c lead out to end places
- 9- 1c+4c cross RH, cast to ends, meet in promhold and dance in between end couples, curve round the other couple Rsh to finish 1c / 4c on M/W side facing out and right
- 17- 1c & 4c (in promhold) Rsh Reels3 with the »corners« on M/W sides, at end meet in the centre
- 25- 4c+1c RHA, at end M swivels right so couples face ends of set (1c down, 4c up, W on P's left, RHJ) ; 4c&1c cross down between end couples and cast in to 3pl/2pl (to 2,4,1x,3x)

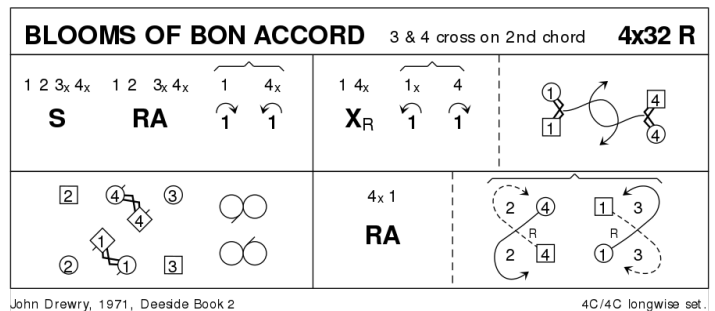

20 THE FIRST RAIN OF SPRING

J32 · 3/3L

Wouter Joubert: RSCDS XLIX 4 · Crib: SCDDDB Contributed Cribs & Diagrams · Diagram: Keith Rose's Diagrams

- 1-- 1c dance down below 3c | cast up 1 place ; dance up to 1pl facing out | 1c+2c ½ turn EH, 2c face out
- 9-- 2c+1c DbIFig8, 1c crossing up
- 17-20 1c+3c turn P RH ¾ and face P up/dn | set ;
- 21-28 (½ Celtic Reel) 1c+3c pass Rsh | "outers" chase ¼ way clw **while**{2} "inners" turn (no hands) ¾ Lsh to face same person ; repeat
- 29-32 1c+3c Turn P RH ¾ | all set

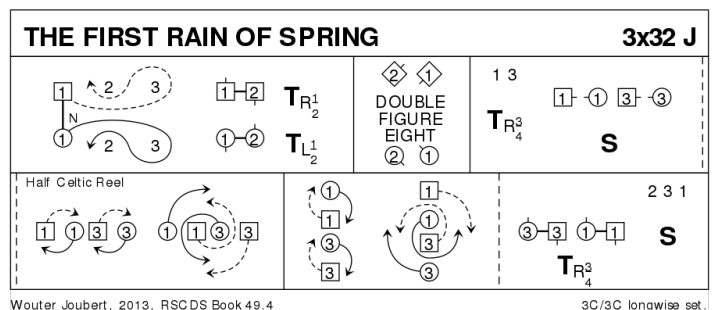

21 MAY YARKER'S STRATHSPEY S32 · 3/4L

Roy Goldring: RSCDS XLII 5 · Crib: Eric Ferguson's SCD Cribs · Diagram: Keith Rose's Diagrams

- 1- 1c cross RH and face out | 1c+3c $\frac{3}{4}$ of a double fig8 round 2c, 3c crossing up to start (to 3,2,1)
- 9- 2c+1c cross RH to sideline | $\frac{1}{2}$ RHA ; 3c+1c repeat (to 1,3,2)
- 17- 1c+3c circle4 L, finish 3c in the sidelines and 1c NHJ facing down ; 1c dance down between 3c+2c, and cast up to 2pl (3c up)
- 25- 3c+1c+2c the Knot (to 2,1,3)

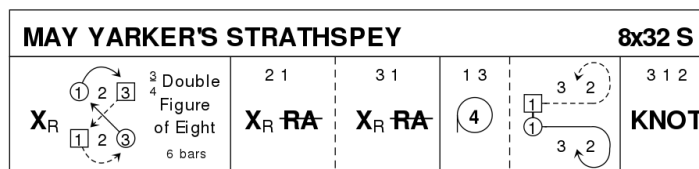

Roy Goldring, 1995, RSCDS Book 42.5

3C/4C longwise set.

Dedicated to May Yarker, awarded the RSCDS Scroll in 1995