

Leeds Club Dance 19 December 2014

Leeds Scottish Country Dance Club Dance

St Chad's Parish Centre, 19th December 2014 7.30

Dancing to Ian Slater MC - Patricia Lynch

1 TAMBOURINE R32 · 3/4L

Lawrie Bowlen: East Ivanhoe Book · Crib: MiniCribs · Diagram: Keith Rose's Diagrams

- 1-8 1s lead down the middle & back to 2nd place own side
- 9-16 1s dance 1/2 reels of 3 across (Lady with 2s & Man with 3s) & 1/2 reels of 3 on opposite sides
- 17-24 1s dance 1/2 reels of 3 across (Man up Lady down) & 1/2 reels on own sides
- 25-32 2s+1s+3s circle 6H round & back

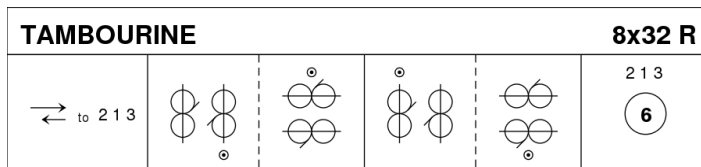

Lawrie Bowlen, East Ivanhoe Bk

3C/4C longwise set

2 THE ZOOLOGIST J32 · 3/4L

Duncan Brown: RSCDS XLVI 12 · Crib: MiniCribs · Diagram: Keith Rose's Diagrams

- 1-8 1s cross down between 2s+3s & cast to right to face 2L/3M, dance 1/2 LSh reel of 3 across (1L with 2s, 1M with 3s) & end facing 1st corner (pstn)
- 9-16 1s dance 1/2 diagonal reel of 4 & pass RSh to face 2nd corner (pstn), 1s dance 1/2 diagonal reel & end in double triangle positions (facing opp sides)
- 17-24 1s dance Double Triangles & end in middle facing opposite sides RSh to RSh
- 25-32 1s dance LH across (M with 3s at top & L with 2s), 1M followed by 3M+3L also 1L followed by 2L+2M pass RSh diagonally across to change ends & loop round to right to end on own sides. 2 1 3

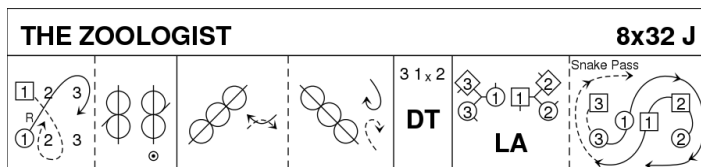

Duncan Brown, RSCDS Book 46

3C/4C longwise set.

3 ARGYLL STRATHSPEY S32 · 3/4L

Roy Goldring: RSCDS XXXV 3 · Crib: MiniCribs · Diagram: Keith Rose's Diagrams

- 1-8 1s+2s+3s 1/2 turn RH, twirl & dance out to opposite sides & repeat back to place
- 9-16 1s+2s+3s circle 6H round & back (1s end in centre facing down & 3s in centre facing up)
- 17-24 1s+3s dance R&L (up & down) & end back on own sides
- 25-32 1s+2s dance the Tournee:
1s+2s dance into prom hold (Men with prtner on right, 1s face M's side & 2s L's side), couples 1/2 wheel antic'lwise & Men turn Ladies into middle, both couples turn 1.1/2 times (2s RH, 1s LH) & dance out to places

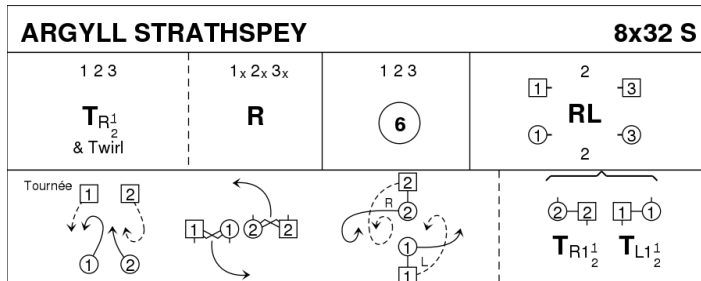

Goldring, 1985, RSCDS Book 35

3C/4C longwise set.

4 THE MONTGOMERIES' RANT R32 · 3/4L

Castle Menzies (18C): RSCDS X 1 · Crib: MiniCribs · Diagram: Keith Rose's Diagrams

- 1-8 1s cross RH & cast down to 2nd place, cross LH & 1L casts up **while** 1M casts down
- 9-16 1s dance reels of 3 across, 1L with 2s & 1M with 3s
- 17-24 1s with nearer hands joined (Lady on Mans left) set to 2L & turn inwards to set to 3M, set to 3L & turn inward & set to 2M
- 25-32 2s+1s+3s dance reels of 3 on opposite sides 1s giving RSh to 2nd corner, 1s cross RH to 2nd place own sides

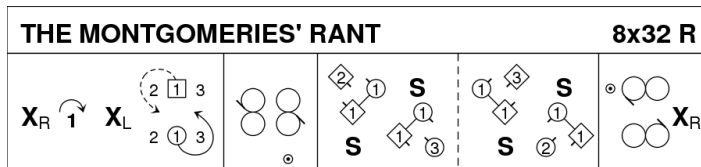

Castle Menzies, 1749, RSCDS Book 10

3C/4C longwise set.

5 THE BEES OF MAGGIEKNOCKATER J32 · 4/4L

John Drewry: A Guide to Scottish Country Dancing · Crib: MiniCribs · Diagram: Keith Rose's Diagrams

- 1-8 1s cross RH & cast 1 place, dance RH across with 3s & end 1M+3L also 1L+3M in prom hold facing out to pass corner person RSh
- 9-24 All dance 4x1/2 Reels of 3 on sides (to right to start, then left, right & left) with 1s+3s changing partners in centre at end of each 1/2 Reel to progress Men clockwise & Ladies anticlockwise. End in centre 1s facing down & 3s facing up
- 25-32 1s dance between 3s turning 3s with nearer hand 1.1/2 times, crossing over to own sides & turn 4th person 1.1/2 times (Men RH & Ladies LH)

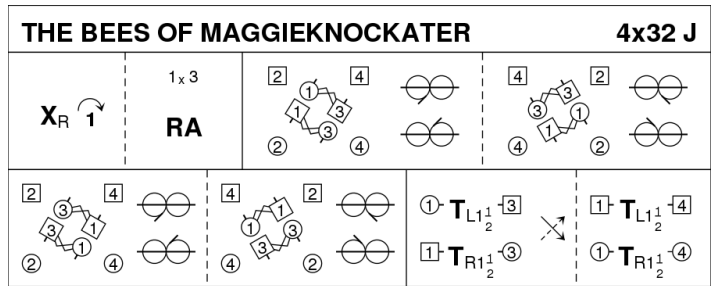

John Drewry, 1975, Canadian Book

4C/4C longwise set.

6 THE LAMMERMUIR HILLS S32 · 2/4L

Roy Goldring: Wells House and other strathspeys · Crib: MiniCribs · Diagram: Keith Rose's Diagrams

- 1-8 1s+2s dance DiamondPoussette
- 9-16 1L+2M cross RH & cast behind partners back to original places, 1s+2s dance RH across
- 17-24 1M+2L cross LH & cast behind partners back to original places, 1s+2s dance LH across
- 25-32 1s+2s dance the Knot

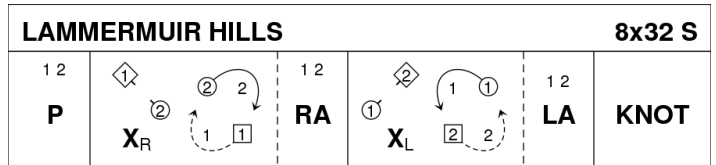

Roy Goldring, Wells House

2C/4C longwise set

7 THE ELEPHANT'S STAMPEDE J48 · 4S

Lorna Macdonald & Gillian Mackintosh: Aurora 10th Anniversary Book of SCD · Crib: MiniCribs · Diagram: Keith Rose's Diagrams

- 1-8 All circle 8H round & back
- 9-16 1s+3s advance & with free hand join with 2s & 4s & retire into longwise set across the dance, all dance 1/2 parallel reels of 4 across
- 17-24 All dance 1/2 R&L at each end of set, turn (person on Mans left) RH 1.1/2 times to form Sq.Set
- 25-32 All Ladies petronella turn to next Ladies place to right & set, repeat to meet partner (all have progressed 1 place to right)
- 33-48 All dance full Schiehallion Reel

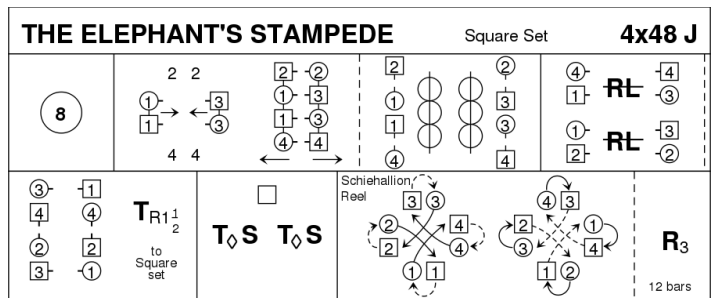

Lorna Macdonald & Gillian Mackintosh, 1995, Aurora 10th Anniversary Book

4C/4C square set

8 THE WIND ON THE HEATH R32 · 3/4L

Iain Boyd · Crib: MiniCribs

- 1-8 1s set, 1L followed by partner casts 2 places, 1L crosses (below 3s) & casts up on Men's side to partners place **while** 1M dances round 3L & up the middle to partners place facing out
- 9-16 1s dance reel of 3 on sides (RSh to 2s to start)
- 17-24 1M followed by partner casts 2 places, 1M crosses (below 3s) & casts up on Men's side to original place **while** 1L dances round 3L & up the middle to original place & 1s set
- 25-32 1s+2s dance the Chain Progression :
1s & 2s 3/4 turn RH, 1M+2L turn LH 1.1/2 times **while** partners chase clockwise 1/2 way, 2s & 1s 3/4 turn RH to end on sides in order 2 1

9 PROGRAMME ITEM – interval

10 FINDLATER CASTLE R32 · 3/4L

Bill Forbes: Jubilee Book 1929-2004 · Crib: MiniCribs

- 1-8 1s cross down RH to 2nd place & Bal-in-Line with 1st+2nd corners, turn 1st corner RH, partner LH to 2nd place own sides facing out
- 9-16 1s dance reels of 3 on own sides (LSh to 4th corner) & pass partner LH to...
- 17-24 1s dance RH across (1L with 2s, 1M with 3s) into 2nd place own sides & 2s+1s+3s chase clockwise 1/2 way
- 25-32 All Set+Link for 3 twice

11 MIDNIGHT OIL J48 · 5/5L

John Drewry: Bankhead Book Part 3 · Crib: MiniCribs · Diagram: Keith Rose's Diagrams

- 1-8** 1s & 3s lead down & 3/4 turn RH to L facing down & M up, retaining hold of RH set & L turns under ptrns Rt arm to dance up (Men follow ptrnr)
- 9-16** 1s & 3s dance RH across with 2L/4L, 1s & 3s dance LH across with 4M/5M to end facing 1st corners
- 17-24** 1s also 3s dance Pass+Turn with 1st corners & pass RSh to face 2nd corners, dance Pass+Turn with 2nd corners & into centre facing partner (L facing down M up)
- 25-32** 1s+3s dance reel of 4 up & down centre of dance & end in centre holding partners nearer hand (1s face Ladies side & 3s face Men's side)
- 33-40** 1s also 3s dance out sides & cast, dance in to meet ptrnr (1M & 3L pass LSh) to dance out other side & cast back to middle (1M & 3L pass RSh & face each other)
- 41-48** 1L also 3M set twice **while** 1M+3L turn RH, 1s & 3s turn partner LH & cast down 1 place on own sides

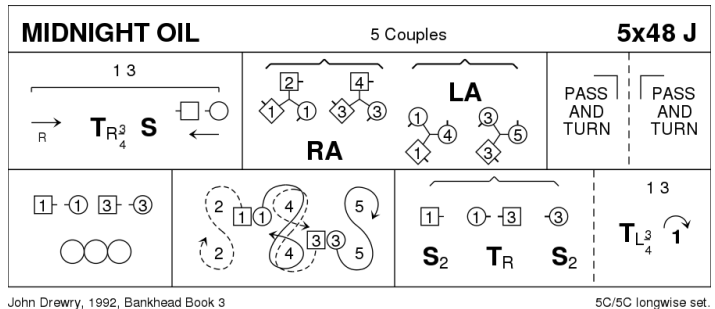

12 THE ROBERTSON RANT S80 · 4S

Mrs Douglas Winchester: RSCDS XXXIX 8 · Crib: MiniCribs · Diagram: Keith Rose's Diagrams

- 1-8** All circle 8H round & back
- 9-16** All Ladies dance RH across 1/2 way & turn opposite Man LH, all Ladies dance 1/2 RH across & turn partner LH
- 17-24** 1s+3s dance reel of 4 (Ladies start by passing LSh as Men set)
- 25-32** All set (HS) to corners, turn 2H twice
- 33-40** 2s+4s dance reel of 4 with Ladies starting by passing LSh
- 41-48** All set (HS) to corners, turn 2H twice
- 49-56** All Ladies circle left to face partners (Ladies BtoB), set to & turn partners 2H
- 57-64** All Men circle right to face partners (Men BtoB), set to & turn partners 2H
- 65-72** All dance Grand Chain
- 73-80** All Allemande anticlockwise

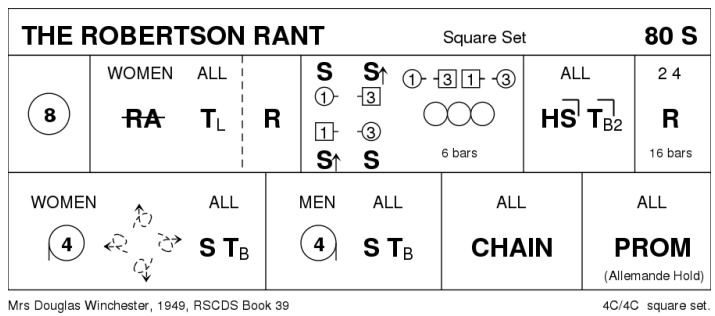

13 THE FALLS OF ROGIE R32 · 3/4L

Jean Attwood: Alexander Dances Book 1 · Crib: MiniCribs · Diagram: Keith Rose's Diagrams

- 1-8** 1s cross RH & cast 1 place, 1s cross RH & cast 1 place (Man up Lady down)
- 9-16** 1s dance 1/2 reels of 3 across (1M with 2s & 1L with 3s), set in lines across & change places RH with opposite person
- 17-24** 2s+1s+3s chase cl'wise 1/2 way, 1s dance in & turn RH to face 1st cnr ptns as 2s & 3s continue to chase on to places (as bar 16)
- 25-32** 1s dance 1/2 reel of 4 with 1st corners, passing RSh dance 1/2 reel with 2nd corners & cross passing RSh to 2nd place own sides

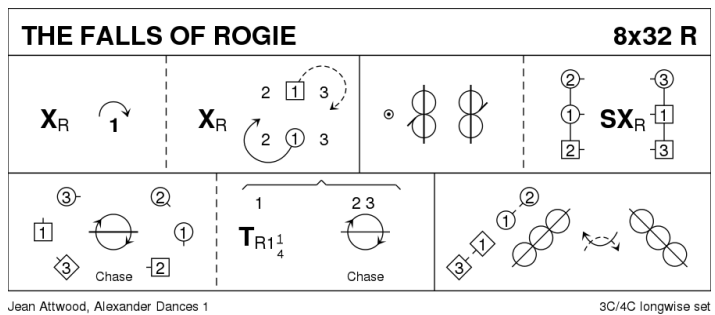

14 IAN POWRIE'S FAREWELL TO AUCHTERARDER

J128 · 4S

Bill Hamilton: 90 - Twelve anniversary dances celebrating ninety years of RSCDS Edinburgh Branch 13 · Crib: MiniCribbs · Diagram: Keith Rose's Diagrams

- 1-8 All circle 8H round to the left & back (popular variation - 8 hands all the way round to left)
- 9-24 Ladies dance in front of ptrn & behind next Man, into RH across, in front of Man opp own ptrn & behind next Man, into RH across & back to place
- 25-32 All Promenade clockwise
- 33-40 1s & 3s dance cl'wise behind next couple & Men dance past cple as Ladies dance in between cple & both turn R to face cple, all set & turn RH
- 41-48 All dance parallel reels of 4
- 49-56 1s & 3s dance a full Fig of 8 round the standing 2s/4s
- 57-64 1s & 3s dance LH across, 1s & 3s dance back to places (Men round & Ladies through the standing 2s & 4s)
- 65-96 2s & 4s repeat 33-64
- 97-104 All Promenade anticlockwise
- 105-120 Men dance in front of ptrn & behind next Lady, into LH across, dance in front of Lady opp own partner & behind next L into LH across & back to pl
- 121-128 All circle 8H round to the right & back (popular variation - 8 hands all the way round to right)

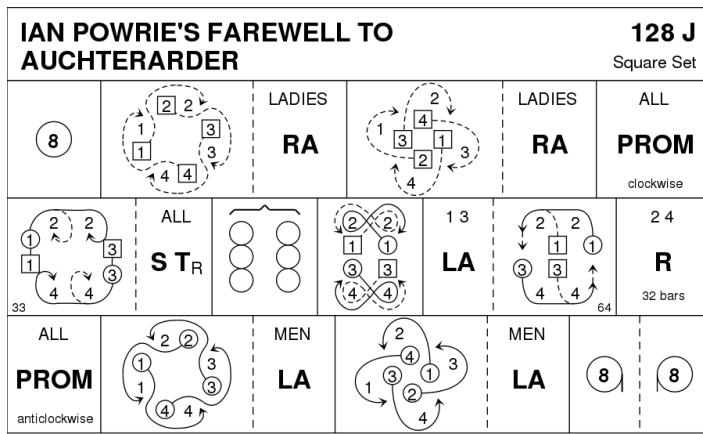

Bill Hamilton, Ian Powrie's Farewell to Auchterarder 4C/4C square set.

15 THE MORAY RANT S48 · 3/3L

John Drewry: Silver City Book of SCD · Crib: MiniCribbs · Diagram: Keith Rose's Diagrams

- 1-8 1s dance Inveran Reels with 2s+3s & 1s cross RH to opposite sides
- 9-16 1s set advancing & turn 2H, dance down & out between 2s & 3s then cast down behind 3s to turn in to face 3s
- 17-24 1s set & turn 3s (1s dancing out between 2s & 3s), dance up between 3s & out between 2s+3s then cast up behind 2s to turn in to face 2s
- 25-32 1s set & turn 2s (1s dancing out between 2s & 3s) into 1st place opp sides, 1s dance 1/2 Fig of 8 round 2s back to 1st place own sides
- 33-40 1s+2s circle 4H once round to Left, 1s facing 2s set & 1s cast to 2nd place as 2s lead up to 1st place
- 41-48 1s+3s circle 4H once round to Left, 1s facing 3s set & 1s cast to 3rd place as 3s lead up to 2nd place

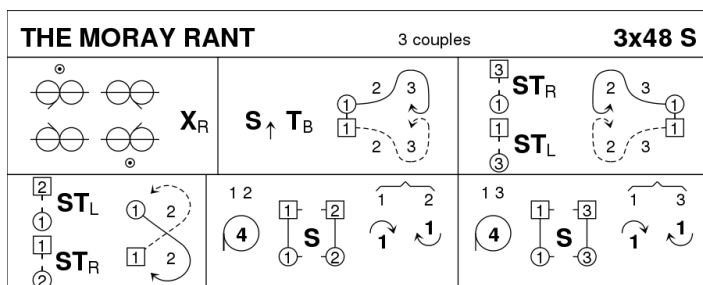

John Drewry, 1968, Silver City 3C/3C longwise set.

16 SWISS LASSIE R32 · 3/4L

Rosi Betsche: RSCDS XXXIX 1 · Crib: MiniCribbs · Diagram: Keith Rose's Diagrams

- 1-8 1s dance in & cast to 3rd place, 2s+1s turn partners RH 1.1/4 times to form a line up & down middle of set (Men facing down Ladies up)
- 9-16 2s+1s dance reel of 4 up & down middle of set ending with 2M facing Ladies side & 1L facing Men's side
- 17-24 2s+1s chase round clockwise 1/2 way, 1s+3s+2s Adv+Ret
- 25-32 3s+2s 1/2 turn partners RH, dance RH across 1/2 way, 1s+2s 1/2 turn partners RH & dance RH across 1/2 way

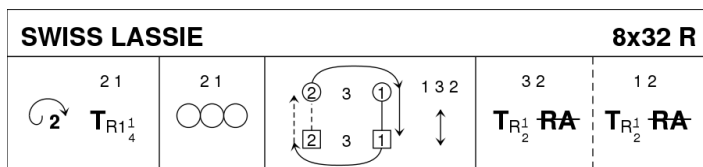

Rosi Betsche, RSCDS Book 39 3C/4C longwise set.

17 THE IRISH ROVER R32 · 3/4L

James B Cosh: Twenty Two SCD and Two Others · Crib: MiniCribbs · Diagram: Keith Rose's Diagrams

- 1-8 1s dance down below 3s & cast up to 2nd place own sides, 1L dances RH across with 2s while 1M dances RH across with 3s
- 9-16 1s dance 1/2 diagonal reel of 4 with 1st corners, 1/2 reel with 2nd corners & 1/2 turn LH in centre to face 1st corners
- 17-24 1s dance reels of 3 across giving LSh to 1st corners ending in 2nd place own sides
- 25-32 1s dance Diag R&L (1M crossing down & 1L crossing up to start)

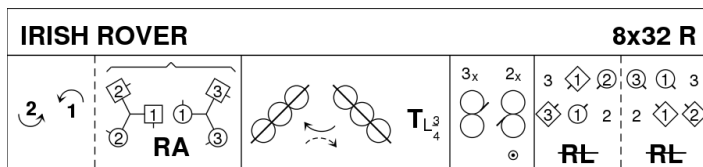

James Cosh, 22 SCD & 1 other 3C/4C longwise set

18 PROGRAMME ITEM – extras

19 INDIAN RIVER STRATHSPEY S32 · 3T

George Senyk: *Scottish Country Dances in Diagrams, Supplement to the 8th Edition · Crib: MiniCrib*s · Diagram: Keith Rose's Diagrams

- 1-8 1s+2s+3s in prom hold dance a reel of 3 across the set, 1s passing 3s RSh to start
- 9-16 1s (with Lady leading) dance RH across with 3s & dance LH across with 2s
- 17-24 2s+3s dance Ladies Chain across the set **while** 1s set & dance between 2s+3s & cast individually back to places
- 25-32 1s+3s dance 1/2 R&L, 1s+2s dance 1/2 R&L to end 3 1 2

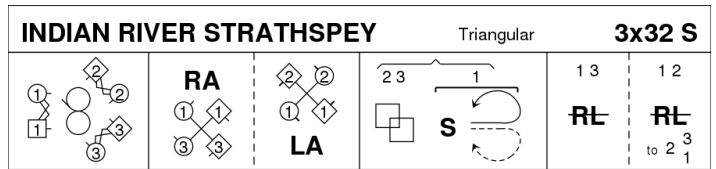

George Senyk, Strathspey 04.12.2000

3C/3C triangular set.

20 GENERAL STUART'S REEL R32 · 3/4L

Castle Menzies (18C): *RSCDS X 3 · Crib: MiniCrib*s · Diagram: Keith Rose's Diagrams

- 1-8 1M sets to 2L & casts 1 place, 1L sets to 2M & casts 1 place
- 9-16 1s turn 1st corner RH & pass partner RSh, turn 2nd corner LH pass partner RSh to face 1st corners
- 17-24 1s dance 'Hello-Goodbye' setting & end BtoB (1M facing up & 1L facing down)
- 25-32 1s give RSh to 2nd corner & dance reels of 3 on sides with 2s+3s & cross RH to 2nd place on own sides

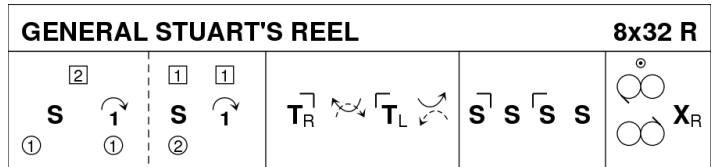

Castle Menzies, 1749, RSCDS Book 10

3C/4C longwise set.

21 BRATACH BANA R32 · 3/4L

John Drewry: *Bon Accord Book of Scottish Country Dances · Crib: MiniCrib*s · Diagram: Keith Rose's Diagrams

- 1-8 1s turn RH & cast 1 place, 1s dance LSh round 1st corners to 2nd place opposite side facing 2nd corners
- 9-16 1s dance 1/2 Reel of 3 on the sides & dance 1/2 Reel of 3 across (1M with 3s at top, 1L with the 2s)
- 17-24 1s turn LH, turn 3rd crnr RH (1st crnr person) & pass RSh to turn 4th crnr RH ending in 2nd pl own side in prom hold with 4th crnr
- 25-32 1s+4th crnr Prom diag across (pass RSh) to diag opp crnr & 1/2 turn to end 1s in 2nd pl opp side, 1s dance 1/2 Diag R&L (M up, L dn) to end in 2nd pl

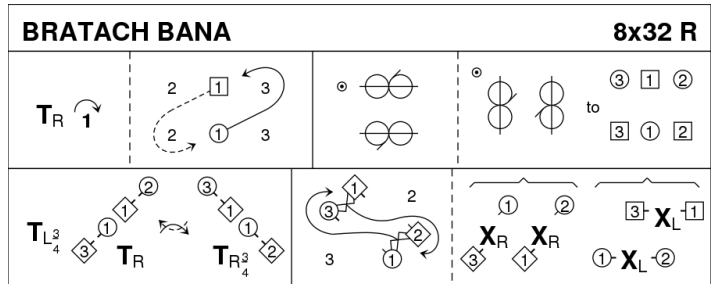

John Drewry, Bon Accord Book

3C/4C longwise set

22 POSTIE'S JIG J32 · 4/4L

Roy Clowes: *Commonwealth Ceilidh Dances · Crib: MiniCrib*s · Diagram: Keith Rose's Diagrams

- 1-8 1s & 4s set & cast in 1 place, 1s & 4s dance 1/2 Figs of 8 round new end couples
- 9-12 1M+4M & 1L+4L cross (men making an arch) & turn corners with free hand to face up/down
- 13-16 1s+4s dance down/up (couple dancing up make the arch) & turn corners
- 17-24 Repeat bars 9-16 from new pstns
- 25-32 1s+4s dance 1/2 R&L, turn partner RH

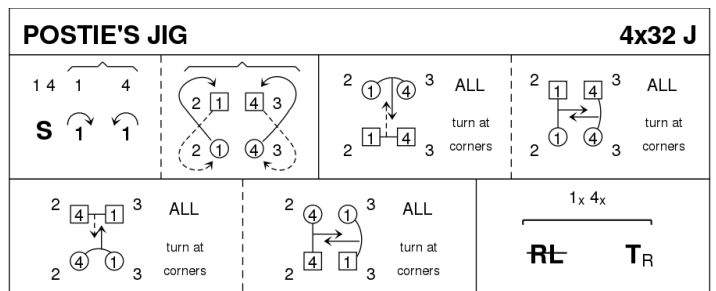

Roy Clowes, Ormskirk 5

4C/4C longwise set