

Leeds Branch 19 September 2015

Music: Alan Ross Duo MC: Veronica Hughes

St Chad's Parish Centre, Headingley

1 MAXWELL'S RANT R32 · 3/4L

Rutherford: RSCDS XVIII 10 · Crib: MiniCrib · Diagram: Keith Rose's Diagrams

- 1-8 1s cross down to dance reflection reels of 3 on opposite sides
- 9-16 1s cross down to dance reflection reels of 3 on own sides
- 17-24 1s cross RH, cast to 2nd place & dance 1/2 Fig of 8 round 2s
- 25-32 1s lead down between the 3s, cast up to 2nd place & 2s+1s+3s turn partners RH

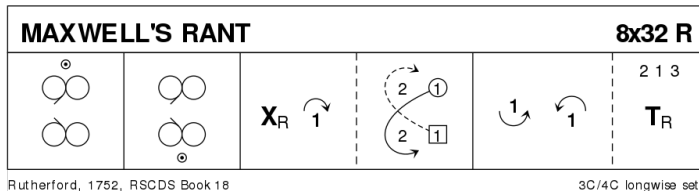

2 THE WILD GEESE J32 · 3/4L

RSCDS XXIV 3 · Crib: MiniCrib · Diagram: Keith Rose's Diagrams

- 1-8 1s+3s set advancing & Bal-in-Line, turn partners RH & 1s cast to 3rd place **while** 3s lead up to 1st place
- 9-16 3s+1s set advancing & Bal-in-Line, turn partners RH & 3s cast to 3rd place **while** 1s lead up to 1st place
- 17-24 1s lead down & back to 2nd place
- 25-32 2s+1s dance R&L

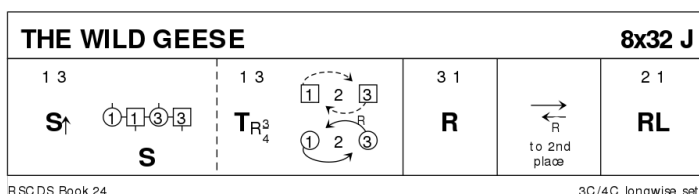

3 ALISON ROSE S32 · 4/4L

Derek Ivory: Imperial Book of Scottish Country Dances – Volumes 1–3 · Crib: MiniCrib · Diagram: Keith Rose's Diagrams

- 1-8 1s lead down to bottom, all set & circle 8H round to left 2 places (end with Men at top of dance & Ladies at bottom)
- 9-16 Men dance LH across & Ladies RH across once round, continue but change places with partner when passing thru middle in order 1 4 3 2
- 17-24 As 1s (+4s+3s+2s) meet again (Men drop RH) & leads his prtnr round to end 1s (followed by 4s+3s+2s) leading up to top, all 1/2 turning RH into...
- 25-32 All dance Allemande ending 2 3 4 1

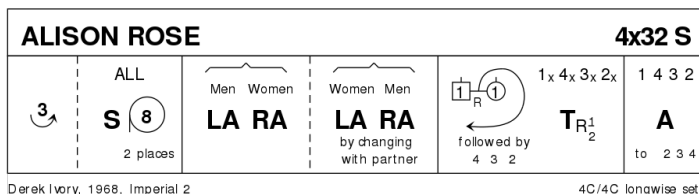

4 PROGRAMME ITEM – Tutor's Choice

5 THE BARMKIN R88 · 4S

Roy Goldring: A Second Book of Graded Scottish Country Dances · Crib: MiniCrib · Diagram: Keith Rose's Diagrams

- 1-8 1s+3s turn partners RH & Men followed by Ladies chase clockwise 1/2 way round set
- 9-16 1s+3s dance RH across in centre & LH back to "new" places
- 17-32 2s+4s repeat bars 1-16
- 33-40 1s+3s turn partners LH & Ladies followed by Men chase anticlockwise 1/2 way round set
- 41-48 1s+3s dance R&L
- 49-64 2s+4s repeat bars 33-48
- 65-72 All dance into centre & return with corners, Ladies dance round corners passing in front to begin & back to place
- 73-80 All with corners dance into centre & return with partners, Men dance round partners passing in front to begin & back to place
- 81-88 All circle 8H round & back

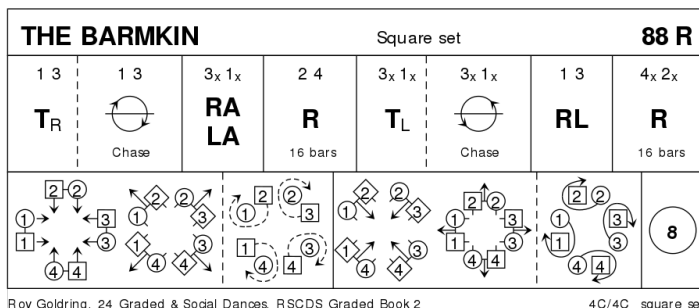

6 SUGAR CANDIE S32 · 3/4L

RSCDS XXVI 9 · Crib: MiniCribs · Diagram: Keith Rose's Diagrams

- 1-8 1s set & cast 1 place, cross passing LSh & cast RSh round their 1st corner into centre ending BtoB (Lady facing up, Man down)
- 9-16 1L circle left with 2s & 1M with 3s, turn to face partner & set, 3/4 turn partner 2H to end facing 1st corners
- 17-24 1s turn 1st corner RH, partner LH, 2nd corner RH, partner LH & end facing 1st corners
- 25-32 1s dance Reel of 3 on opposite sides passing 1st corner LSh & cross RH to 2nd place own sides

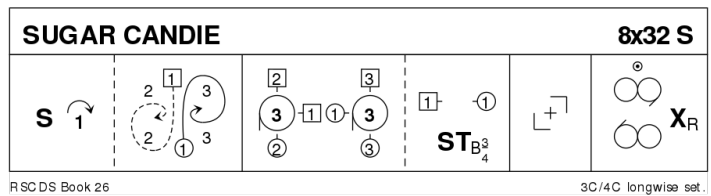

7 THE WEATHERCOCK J32 · 4/4L

Veronica Hughes: A Second Book of Graded Scottish Country Dances · Crib: MiniCribs · Diagram: Keith Rose's Diagrams

- 1-8 All dance RSh reels of 4 on own sides
- 9-16 1s & 3s set advancing into centre (give RH to partner) & Bal-in-Line, 1s+2s & 3s+4s dance RH across once round
- 17-24 Centre couple (1L+3M) 3/4 turn LH in centre while 1M & 3L dance round crrr to meet ptrnr in line across & set, repeat & set in line up/down dance
- 25-32 3s+2s & 1s+4s dance RH across once round, turn facing corner RH (2L+3L, 3M+2M, 1L+4L & 1M+4M) onto own sides (Ladies turn 1.1/2 while Men turn once round). 2 3 4 1

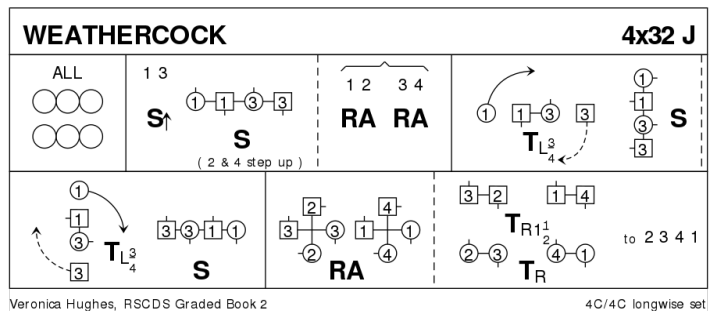

8 THE MONTGOMERIES' RANT R32 · 3/4L

Castle Menzies (18C): RSCDS X 1 · Crib: MiniCribs · Diagram: Keith Rose's Diagrams

- 1-8 1s cross RH & cast down to 2nd place, cross LH & 1L casts up while 1M casts down
- 9-16 1s dance reels of 3 across, 1L with 2s & 1M with 3s
- 17-24 1s with nearer hands joined (Lady on Mans left) set to 2L & turn inwards to set to 3M, set to 3L & turn inward & set to 2M
- 25-32 2s+1s+3s dance reels of 3 on opposite sides 1s giving RSh to 2nd corner, 1s cross RH to 2nd place own sides

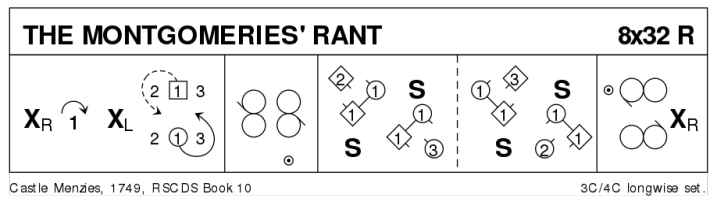

9 PROGRAMME ITEM – Interval

10 MAJOR IAN STEWART J32 · 3/4L

John Drewry: RSCDS XXXV 4 · Crib: MiniCribs · Diagram: Keith Rose's Diagrams

- 1-8 1s+2s 1/2 turn partners RH & dance RH across 1/2 way, 2s+1s full turn partner RH ending with 2s at top & 1s in 2nd place
- 9-16 2s+1s+3s dance reels of 3 on own sides (1L dances in & up as 1M dances in & down to start) & 1s end facing 1st corners
- 17-24 1s set to 1st corners then to each other across the dance, set to 2nd corners & Petronella turn to 2nd place own sides
- 25-32 2s+1s+3s circle 6H round to the left for 6 steps, pivot & chase back to places

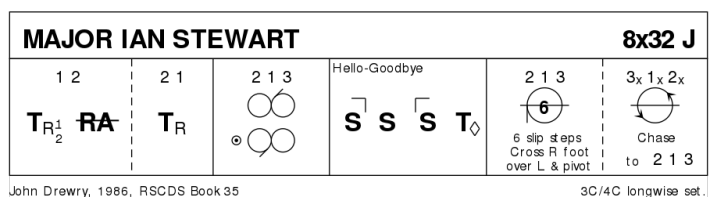

11 THE MILLER OF SESSNIE J32 · 5/5L

Roy Goldring: 15 Social Dances · Crib: MiniCribs · Diagram: Keith Rose's Diagrams

- 1-8 1s followed by 2s+3s+4s dance down & cast round 5s back to places
- 9-16 1s & 5s dance Figs of 8 on own sides (1s down between 2s & 5s up behind 4s to start)
- 17-24 1s+2s dance RH across, 1s cross down & 1/2 turn 3s (LH Men's side & RH Ladies side)
- 25-32 1s+4s dance LH across, 1s cross down & 1/2 turn 5s (LH Men's side & RH Ladies side). 2 3 4 5 1

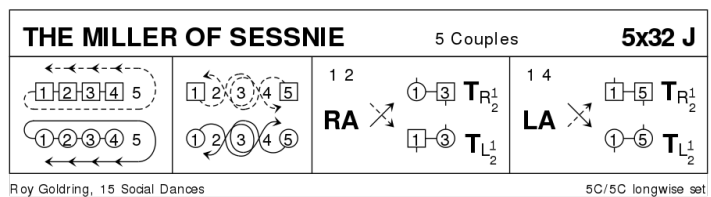

12 PROGRAMME ITEM – Tutor's choice

13 QUARRIES' JIG J32 · 3/4L

Kent W Smith: RSCDS XXXVI 3 · Crib: MiniCribs · Diagram: Keith Rose's Diagrams

- 1-8 1s set, cast 1 place & dance round 1st corners passing corners LSh
- 9-16 1s dance reels of 3 across (1st Man with 2s & 1st Lady with 3s), 1s turn LH to face 1st corners
- 17-18 Centre dancers change with 1st corners RH while 2nd corners set
- 19-20 1st corners (in centre) change places LH while new 1st & 2nd corners dance clockwise round to next corner place
- 21-24 Repeat the Fig in bars 17-20 from new places
- 25-32 Repeat 17-20 from new places, 1s end by turning LH to 2nd place on opposite sides, 2s+1s+3s set on sides & 1s cross back RH

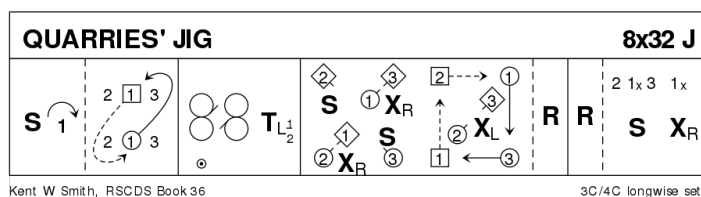

14 MRS MACPHERSON OF INVERAN R32 · 3/4L

John Drewry: A Guide to Scottish Country Dancing · Crib: MiniCribs · Diagram: Keith Rose's Diagrams

- 1-8 1s dance Inveran Reels with 2s+3s
- 9-16 1s turn RH 1.1/2 times moving down to 2nd places (opposite sides), 1s cast up behind 2s & cross down to 2nd place own side
- 17-24 2s+1s+3s dance Grand Chain
- 25-32 2s+1s+3s circle 6H round & back

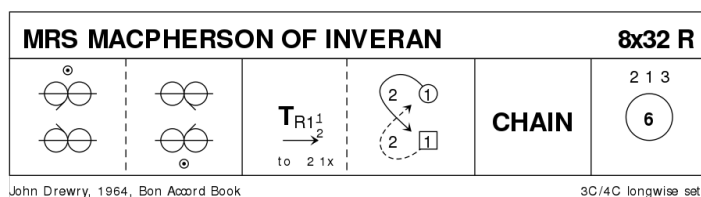

15 THE DREAM CATCHER S96 · 4S

Eileen Orr: RSCDS XLV 9 · Crib: MiniCribs · Diagram: Keith Rose's Diagrams

- 1-8 All circle 8H round & back
- 9-16 1s+3s dance the Swirl: Turn partner RH into Allemande hold & dance LSh round other couple 1/2 way, dance LH across & swirl to face side couples (BtoB with ptrn & Lady facing Man)
- 17-24 All dance reels of 4 across
- 25-32 All set & dancing couples dance out between side couples, cross & cast to change places RH with partner back into places
- 33-40 All set & advance with partners, retire diagonally with corners & set
- 41-48 1L+4M dance R&L with 3L+2M (on diagonal)
- 49-56 1M+2L dance R&L with 3M+4L (other diagonal)
- 57-64 All set with corners, Adv+Ret with partners & set
- 65-88 2s & 4s repeat bars 9-32
- 89-96 All circle 8H round & back

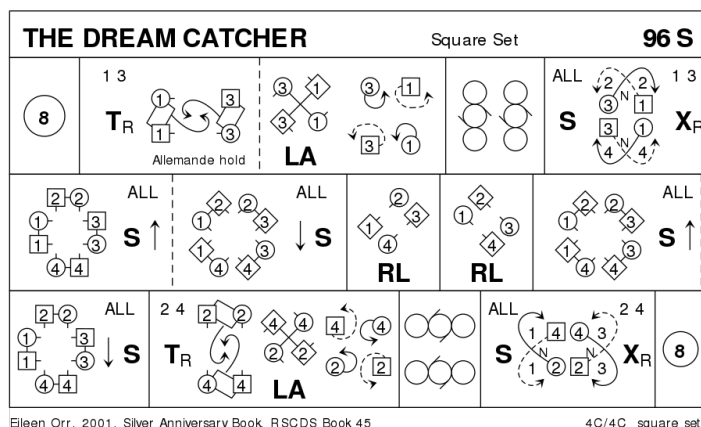

16 SETON'S CEILIDH BAND J64 · 4/4L

A Bruce Fordyce: The Bruce Fordyce Memorial Collection · Crib: MiniCribs · Diagram: Keith Rose's Diagrams

- 1-8 1s cross RH & cast 1 place, lead down between 3s & cast down behind 4s
- 9-16 1s dance reflection reels of 3 on opposite sides beginning by dancing up between 4s
- 17-24 1s cross RH & cast up 1 place, lead up between 3s & cast up behind 2s
- 25-32 1s dance reels of 3 on own sides beginning by dancing down between 2s
- 33-40 1s cross RH & cast down 1 place to give RH to partner & LH to 1st corners, Bal-in-Line & turn partner RH to give LH to 2nd corners
- 41-48 Bal-in-Line & 1s dance out & cast down behind 3s, lead up to top crossing to 1st place own sides
- 49-60 1L+2L & 1M+2M change places RH on sides & 2s+1s cross over LH, repeat with 3s & 4s until reaching the bottom of the set
- 61-64 All turn RH 1.1/2 times

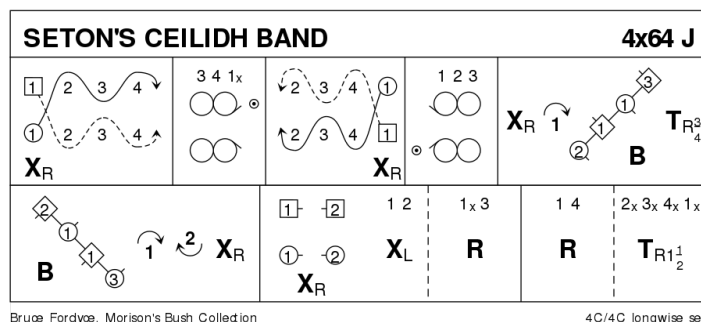

17 DUKE OF PERTH R32 · 3/4L

RSCDS I 8 · Crib: MiniCribbs · Diagram: Keith Rose's Diagrams

- 1-8 1s turn RH, cast to 2nd place, turn LH to face 1st corners
- 9-16 1s turn 1st corner, partner, 2nd corner, & partner to face 1st corners
- 17-24 1s set to & turn 1st corner 2H, set to & turn 2nd corner
- 25-32 1s dance Reel of 3 on opposite sides giving LSh to 1st corner & cross back to own sides

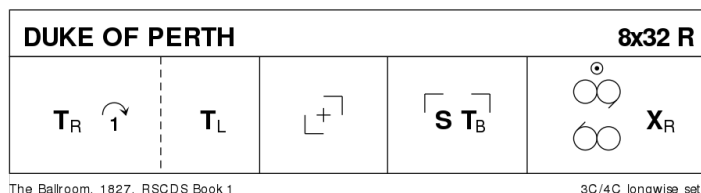

18 PROGRAMME ITEM – Extras

19 THE DEIL AMANG THE TAILORS R32 · 3/4L

RSCDS XIV 7 · Crib: MiniCribbs · Diagram: Keith Rose's Diagrams

- 1-8 1s+2s set & dance RH across 1/2 way, set & dance LH across 1/2 way back to place
- 9-16 1s lead down the middle & back to top
- 17-24 1s+2s dance Allemande
- 25-32 2s+1s+3s circle 6H round & back

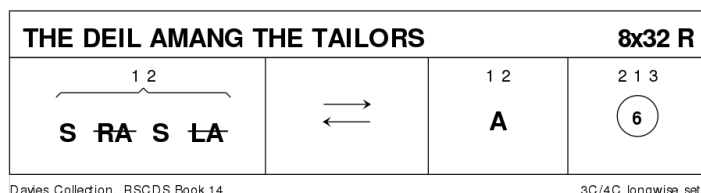

20 SCOTT MEIKLE R32 · 4/4L

Alice McLean: RSCDS XLVI 3 · Crib: MiniCribbs · Diagram: Keith Rose's Diagrams

- 1-8 1s cross RH & cast to 2nd place, 1s dance 1/2 Fig of 8 round 2s
- 9-16 1s+3s dance RH across, LH back
- 17-24 1L followed by 3L dance Tandem reel of 3 across with 2s (LSh to 2M) & 1s end 3rd pl **while** 3M followed by 1M dance reel of 3 with 4s (LSh to 4L & 3s end in 2nd pl 2 3 1 4
- 25-32 1s+4s dance 1/2 R&L, turn partners RH 1.1/2 times 2 3 4 1

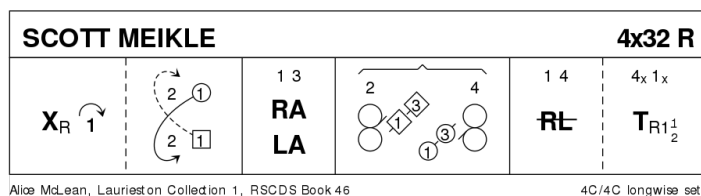

21 HOOPER'S JIG J32 · 3/4L

Miss Milligan's Miscellany of Scottish Country Dances · Crib: MiniCribbs · Diagram: Keith Rose's Diagrams

- 1-8 All clap & 1s cross passing RSh, cast to 2nd place & dance RH across with 3s
- 9-16 All clap & 1s cross passing RSh, cast to 1st place & dance LH across with 2s
- 17-24 1M+3L change places RH & 1L+3M change places RH (as 1M+3L loop round), 1M+3L change places RH (as 1L+3M loop round) & 1L+3M cross LH 1L ending in 2nd place (as 1M casts to 2nd pl)
- 25-32 2s+1s dance R&L

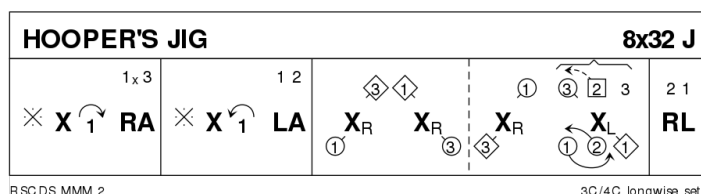

22 BUTTERSCOTCH AND HONEY S32 · 4/4L

Jean Attwood: Alexander Leaflets · Crib: MiniCribbs · Diagram: Keith Rose's Diagrams

- 1-8 1s set & 1/2 turn RH into prom hold, 1s dance 1/2 RSh reel of 3 with 2s (2s end on opposite sides)
- 9-16 1s dance 1/2 LSh Reel of 3 with 3s & 1/2 RSh reel of 3 with 4s
- 17-24 1s followed by 4s+3s+2s cast up on opposite sides to top, cross over to own sides each Lady passing in front of partner & down own side
- 25-32 All set to partners & turn 2H into 4H round (2s with 3s & 4s with 1s)

