

Leeds Branch Dance 20th May 2017

St Edmund's Parish Church 15 North Park Avenue, Leeds, LS8 1EJ

Music: Ian Muir MC: Betty Hagart

1 ECCLEFECHAN FELINE J32 · 3/4L

Bob McMurtry: *Le Petit Chat Celtique* · Crib: Eric Ferguson's *SCD Cribs* · Diagram: Keith Rose's Diagrams

- 1- 1c Fig8 on own side (start in and down ; take NH where possible).
- 9- 1c+2c+3c Mirror Reels3 on own sides (2c start out & up)
- 17- 1c dance down middle {3}, up {3}, and cast off (2c up)
- 25- Teapots R ; and L (1M+3c & 1W+2c RHA, 1c pass Rsh ; 1M+2c & 1W+3c LHA) (2,1,3)

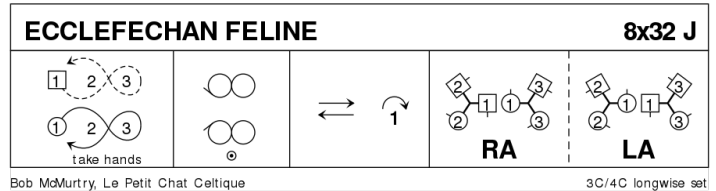

2 PORTNACRAIG R32 · 3/4L

Linda C Gaul: *RSCDS XXXVI 1* · Crib: Eric Ferguson's *SCD Cribs* · Diagram: Keith Rose's Diagrams

- 1- 1c set (no advance), turn BH ½ into the middle NHJ facing 2c diagonally (drop hands) ; 1c set to 2c and face out | turn 2c EH ½ (2,1x,3)
- 9- All A&R ; ½circle6 L (3x,1,2x)
- 17- 1c pass Lsh into ½ Rsh Reel4 with 1cnrs, pass Lsh into ; ½ Rsh Reel4 with 2cnrs (to 2,1x,3)
- 25- 1c ½Fig8 round 3c ; All turn RH (2,1,3)

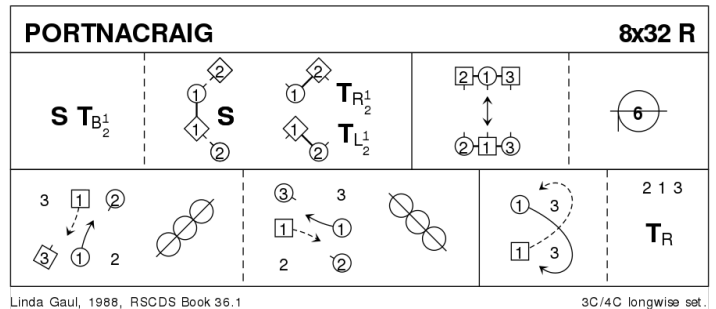

3 MOMENT OF TRUTH S32 · 3/4L

Claudette Sigg: *RSCDS XXXVII 2* · Crib: Eric Ferguson's *SCD Cribs* · Diagram: Keith Rose's Diagrams

- 1- 1c turn BH, cast off (2c up) ; dance NHJ between 3c, cast up to 1cnrs
- 9- Turn CPCP to finish between end cpl facing 1cnrs, 1W above, 1M below
- 17- Lsh Reels3{6} across (to 2,1,3) | All C turn BH
- 25- »Cnrs Pass and Turn«: 1c pass Rsh and loop Rsh round 1cnr positions **while{4}** 1cnrs turn each other BH, to places ; 1c pass Rsh in the middle and repeat with 2cnrs, 1c pass each other Rsh to (2,1,3)

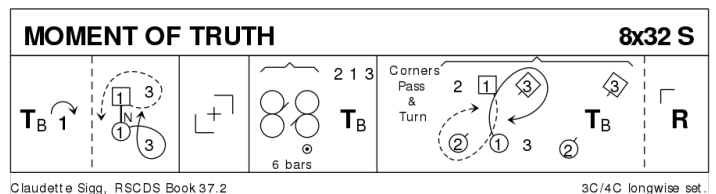

4 SHADOW J32 · 3/3L

Lucy Thompson: RSCDS L 9 · Crib: SCDDDB Contributed Cribbs & Diagrams · Diagram: Keith Rose's Diagrams

- 1-- 1c 1¼ turn LH, moving down to 2pl on midline facing M side, W above M (2c up on [3-4]) ; 1W+2c RHA **while{4}** 1M+3c LHA, all cpls finish in middle, M behind P, 1c facing M side, 2c+3c facing W side
- 9-- Tandem Reel3 on midline, 1c+2c Rsh to start, finish on the sides (2,1x,3) (1W face out)
- 17-- ½ Reels3 on sides, 1c Rsh to 2c ; all set | 1c cross RH (3,1,2)
- 25-- Circle6 and back (3,1,2)

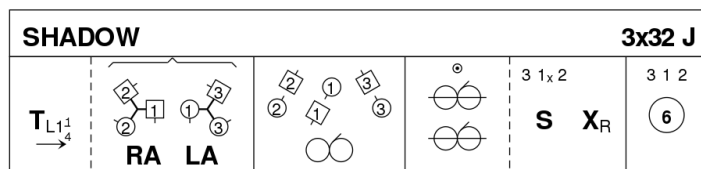

Lucy Thompson, 2014, RSCDS Book 50.9

3C/3C longwise set.

5 GLASTONBURY TOR R32 · 3/4L

Duncan Brown: RSCDS XLVII 11 · Crib: Eric Ferguson's SCD Cribbs · Diagram: Keith Rose's Diagrams

- 1-- 1c+2c set | ½ RHA ; 1c+3c set | ½ LHA (2x,3x,1)
- 9-- 1c set | cross RH ; cast up one (3c down) | turn LH to face 1cnr (pos)
- 17-- ½ diag Reel4 with 1cnrs, pass Lsh ; ½ diag Reel4 with 2cnrs, 1c curve R into facing lines of 3 across, 1M at top, 1W at bottom
- 25-- All S&Link3 ; 1c turn RH 1½ **while{4}** cnrs chase clw ½ round (2,1,3)

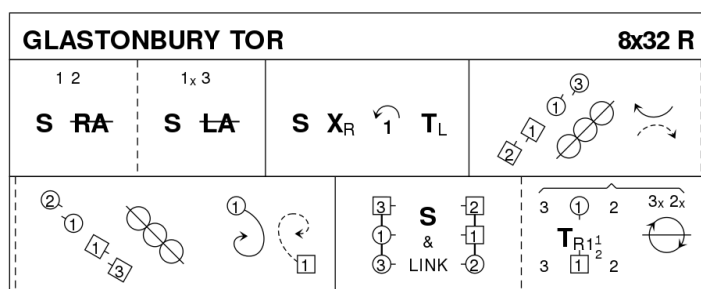

Duncan Brown, 2001, RSCDS Book 47.11

3C/4C longwise set.

6 THE RING OF BRODGAR S32 · 4S

Derek Haynes: Carnforth Collection of SC Dances 5 · Crib: Eric Ferguson's SCD Cribbs

- 1-- 1c Turn BH | dance NHJ into middle ; 1M+2c LHA **while{}** 1W+4c RHA
- 9-- 2c+1c+4c in promhold Rsh Reel3 across.
- 17-- 1c dance out between 3c, divide and cast back to middle ; Turn RH | 1W /1M dance out between 4c / 2c and cast to original place.
- 25-- G-Chain, one step per hand.

Repeat with 2c, 3c, 4c leading.

7 JOIE DE VIVRE J32 · 3/4L

Irene van Maarseveen: RSCDS XXXIX 2 · Crib: Eric Ferguson's SCD Cribbs · Diagram: Keith Rose's Diagrams

- 1-- 1c set | cast (2c up) ; dance between 3c and cast up to (2,1,3)
- 9-- All turn P RH to sidelines ; all chase clw half round (to 3x,1x,2x)
- 17-- All dance BtoB ; all set | all ½ RH turn into
- 25-- 3c+1c+2c Allemande (2,1,3)

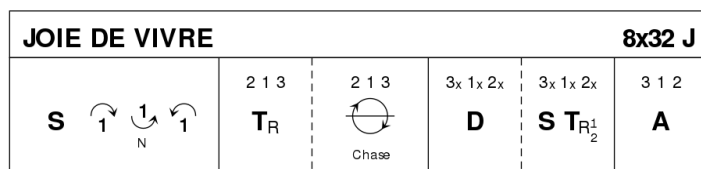

Irene van Maarseveen, 1996, RSCDS Book 39.2

3C/4C longwise set.

8 AIRDRIE LASSIES J48 · 4/4L

RSCDS XXVI 1 · Crib: Eric Ferguson's SCD Cribbs · Diagram: Keith Rose's Diagrams

- 1- All 4 couples NHJ A&R ; all cross Rsh, M making arches
- 9- Repeat, again M making arches
- 17-32 1c & 4c RH tulloch swing, to face down/up, W on the right ; R&L up/down, inside the set {8} ; LH tulloch swing
- 33- 1c+4c L-Chain up/down, 1c finish with full LH turn to own side and face out (1,2,3,4)
- 41- 1c followed by 2c+3c+4c cast off behind own sides, 1c in 4pl make arch ; the others dance up under it, all retire (to 2,3,4,1)

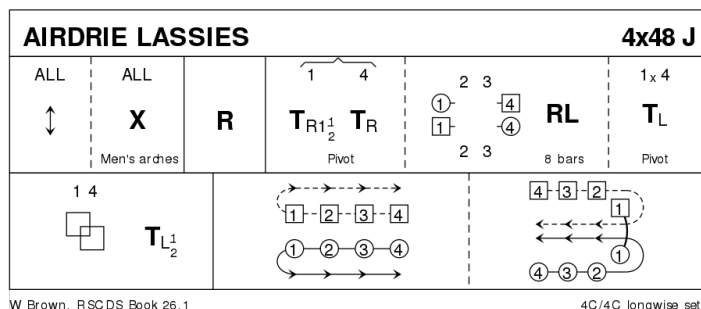

9 INTERVAL

10 BILL CLEMENT MBE J32 · 3/4L

John Wilkinson: RSCDS XLVII 1 · Crib: Eric Ferguson's SCD Cribbs · Diagram: Keith Rose's Diagrams

- 1- 1c set | dance between 3c (2c up) and cast up to finish side by side LHJ facing 1cnr
- 9- Set to 1cnr and turn inwards and join RH | set to 3cnr ; turn 3cnr LH to face 2cnr RHJ
- 17- Set to 2cnr and turn inwards and join LH | set to 4cnr ; turn 4cnr RH to (2,1,3)
- 25- Circle6 and back

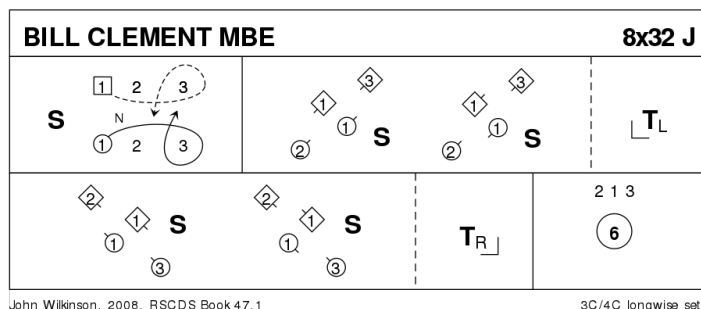

11 THE FALLS OF ROGIE R32 · 3/4L

Jean Attwood: Alexander Dances Book 1 · Crib: Eric Ferguson's SCD Cribbs · Diagram: Keith Rose's Diagrams

- 1- 1c cross RH | cast (2c up) ; cross RH | cast R (M up, W down)
- 9- ½ Reels3 across (Lsh to 2cnr) ; set in lines across | all cross up/down RH
- 17- Corners chase once clw **while{8}** 1c chase half way clw and turn RH ¼ to face 1cnr positions
- 25- ½ diag. Reel4 with 1cnrs, 1c pass Rsh ; ½ diag. Reel4 with 2cnrs, 1c passing Rsh to 2pl.

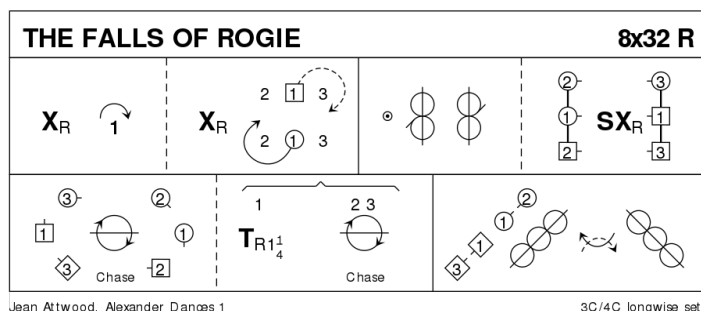

12 MISS GIBSON'S STRATHSPEY S32 · 3/4L

Derek Haynes: *The Leaflet Dances with Music* · Crib: Eric Ferguson's *SCD Crib*s · Diagram: Keith Rose's *Diagrams*

- 1- 1c+2c set | turn BH ; circle4 L
- 9- 1c+2c Knot, 1c finish facing 1cnrs
- 17- Turn CPCP, with final wide $\frac{3}{4}$ LH turn into
- 25- Teapots R and L (1M+3c & 1W+2c RHA, 1c pass Rsh, cnrs not to sidelines ; 1M+2c & 1W+3c LHA) (2,1,3)

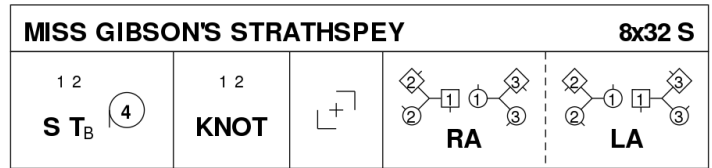

Derek Haynes, 1979, RSCDS Leaflet 10

3C/4C longwise set.

13 A CAPITAL JIG J32 · 3/4L

Tine E MacKay: *Magazine Dances 2005-2009* · Crib: Eric Ferguson's *SCD Crib*s · Diagram: Keith Rose's *Diagrams*

- 1- 1c+2c Set&Rotate, finish 1c facing 2c (2,1,3)
- 9- Rsh Reels3 on the sides
- 17- 1c set | turn $\frac{3}{4}$ RH ; 2c+1W & 1M+3c LHA (to 2,1x,3)
- 25- 1c set | turn $\frac{3}{4}$ RH ; 2c+1M & 1W+3c LHA (2,1,3)

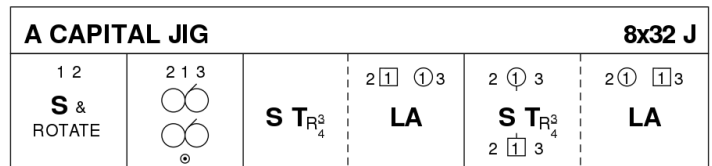

Tine Mackay, RSCDS 5/2009

3C/4C longwise set.

14 THE CUMBRAE REEL R32 · 3/4L

RSCDS XXVIII 8 · Crib: Eric Ferguson's *SCD Crib*s · Diagram: Keith Rose's *Diagrams*

- 1- 1c+2c half R&L ; 2c cross RH to own side **while**{4} 1c dance up to between 2c, all facing up NHJ | set in line across and pivot R the second PdB to face down
- 9- In line of 4 dance down the middle (turn R about) ; and up, finishing with 1c BtoB between 2c
- 17- 1c+2c Reel4 across the dance, 1c finishing facing corners
- 25- 1c turn corner, P, corner, cross over to own sides (2,1,3)

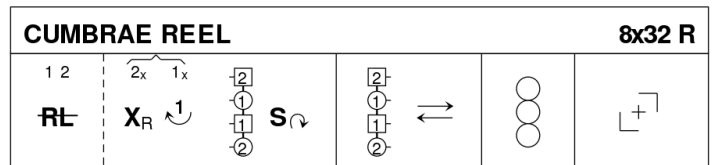

RSCDS Book 28.8

3C/4C longwise set.

15 THE ROSE OF THE NORTH S32 · 3/4L

Roy Goldring: *Silver Jubilee 25 - Leeds Branch* · Crib: Eric Ferguson's *SCD Crib*s · Diagram: Keith Rose's *Diagrams*

- 1-4 1c lead down, cross below 3c and cast up into 2plx (2c up)
- 5-16 2c+1c+3c R&L for 3 couples
- 17- 1c set to and turn corners, to finish BtoB in the centre, 1M facing up, 1W facing down
- 25- 1M+2c & 1W+3c Circle3 L (at end 1c pull Rsh back to face P) ; 1c set, petronella to 2pl

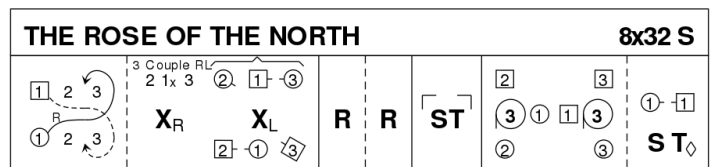

Roy Goldring, 1986, Leeds Silver Jubilee

3C/4C longwise set.

16 FLIGHT TO MELBOURNE R32 · 4S

Shirley Campbell: RSCDS XLVII 3 · Crib: Eric Ferguson's SCD Cribs · Diagram: Keith Rose's Diagrams

- 1- 1M+3W (and 1W+3M) Fig 8 round 2c (4c) (W crossing in front of M), to own places
- 9- 1c & 3c in promhold Rsh Reels3 across with the nearest members of 2c & 4c, to places.
- 17- All C S&Link (to face P) ; turn RH ½ | chase 1 place clw. (4,1,2,3)
- 25- All Circle8 and back (4,1,2,3)

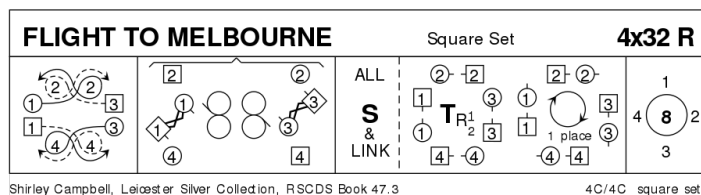

17 THE REEL OF THE ROYAL SCOTS R32 · 3/4L

Roy Goldring: The Leaflet Dances with Music · Crib: Eric Ferguson's SCD Cribs · Diagram: Keith Rose's Diagrams

- 1- 1W+2W (1M+2M) turn LH (RH) ½, finishing 1c BtoB in 2pl | All set as in DTr ; 1W+3W (1M+3M) turn RH (LH) ½ | 2c+3c+1c set as in DTr
- 9- 1c followed by 3c dance up between 2c, cast off ; dance NHJ down through 3pl, cast up to face 1cnrs, 3c looping into 3pl
- 17- 1c turn 1cnrs RH, pass Rsh (cnrs dance for {4}) ; turn 2cnrs RH (same), and cross Rsh to (2,1,3)
- 25- All circle6 and back

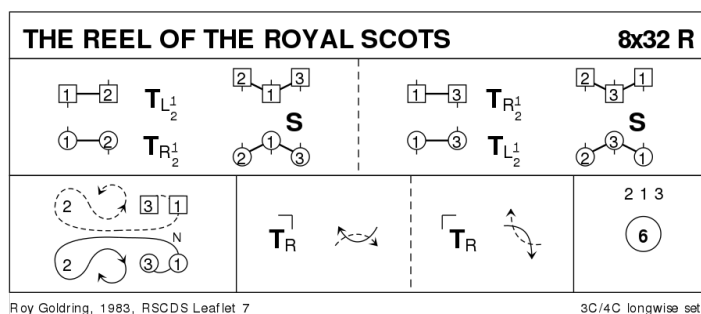

18 EXTRAS

19 ALL THE EIGHTS J32 · 3/4L

Brenda Burnell: The Leeds Golden Collection · Crib: SCDDDB Contributed Cribs & Diagrams · Diagram: Keith Rose's Diagrams

- 1-6 Reel of three on the sides, 1s crossing
- 7-8 1s dance down to face 3m, promenade hold, 2c dance to 1st place
- 9-16 1s dance R Sh reel of three with 2nd corners
- 17-24 1s dance L Sh reel of three with 1st corners
- 24-32 1s cross down between 3s, cast up to 2nd place, dance up between 2s, cast to 2nd place own sides

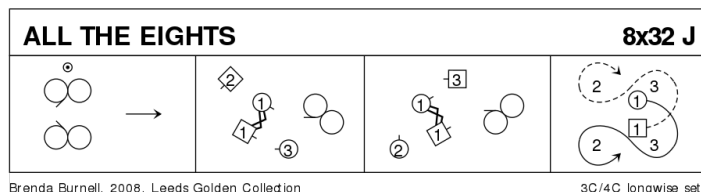

20 CITY OF BELFAST S32 · 3/3L

Lucy Mulholland: RSCDS XLVIII 6 · Crib: Eric Ferguson's SCD Cribs · Diagram: Keith Rose's Diagrams

- 1- 1c ½ Fig8 round 2c ; 1c turn 2c EH 1¼ into line across, 1c in the middle
- 9- 1c+2c Reel4, finish 2c in 1pl and 1c (last pass is Lsh) facing 1cnr
- 17- 1c set to 1cnr | set to 2cnr, dancing R into sideline (2,1x,3) ; All set | 1c cross RH
- 25- 1c+3c Espagnole (2,3,1)

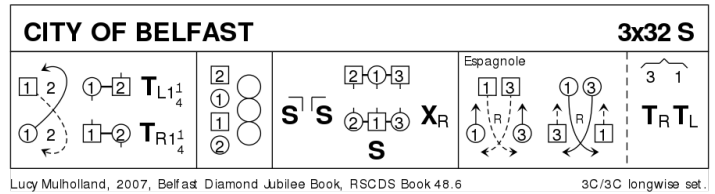

Espagnole: both W lead RHJ to M side, cross and cast back to exchanged places while Men cross to W side, lead RHJ back to M side crossing to exchanged places ; all turn P EH (2,1)

21 THE LADIES OF DUNSE R40 · 3/4L

RSCDS XXVI 11 · Crib: Eric Ferguson's SCD Cribs · Diagram: Keith Rose's Diagrams

- 1- 1c lead down the middle and up {6}, cast off (2c up)
- 9- 2c repeat (1,2,3)
- 17- 2c (1c following) cross down into a Fig8 round 3c, to finish (2,1,3)
- 25- 1c+3c R&L, finish facing 1cnrs (1M has no polite turn)
- 33- 1c set to 1cnr, to 2cnr, pulling Rsh back to sideline facing P ; turn RH 1½ to (2,1,3).

