

Leeds club Dance 24 January 2015

Leeds Scottish Country Dance Club Dance

Cookridge Village Hall 24 January 2015 7.00pm

Music: Recorded MC: Irene Dracup

1 PELORUS JACK J32 · 3/4L

Barry Skelton: RSCDS XLI 1 · Crib: MiniCrib · Diagram: Keith Rose's Diagrams

- 1-8 1s cross RH & cast 1 place, dance RH across with 3s & 1s end with Man facing his 1st corner with his partner behind him
- 9-16 1s dance Alternating Tandem 1/2 reel of 3 with 1st corners, 1s dance Alternating Tandem 1/2 reel with 2nd corners
- 17-24 1s dance Alternating Tandem 1/2 reels of 3 with Ladies 1st corner (pstn), 1s dance Alternating Tandem 1/2 reel with Ladies 2nd corner (pstn)
- 25-32 1M followed by partner dance into LH across with 2s, 1s retain LH & 1/2 turn to own sides & 2s+1s+3s set

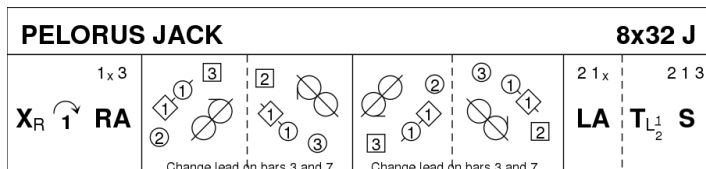

Barry Skelton, 1993, Dolphin Book, RSCDS Book 41

3C/4C longwise set.

2 SWISS LASSIE R32 · 3/4L

Rosi Betsche: RSCDS XXXIX 1 · Crib: MiniCrib · Diagram: Keith Rose's Diagrams

- 1-8 1s dance in & cast to 3rd place, 2s+1s turn partners RH 1.1/4 times to form a line up & down middle of set (Men facing down Ladies up)
- 9-16 2s+1s dance reel of 4 up & down middle of set ending with 2M facing Ladies side & 1L facing Men's side
- 17-24 2s+1s chase round clockwise 1/2 way, 1s+3s+2s Adv+Ret
- 25-32 3s+2s 1/2 turn partners RH, dance RH across 1/2 way, 1s+2s 1/2 turn partners RH & dance RH across 1/2 way

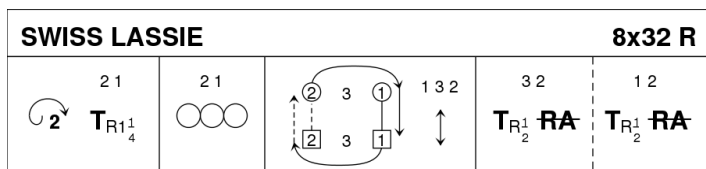

Rosi Betsche, RSCDS Book 39

3C/4C longwise set.

3 SUGAR CANDIE S32 · 3/4L

RSCDS XXVI 9 · Crib: MiniCrib · Diagram: Keith Rose's Diagrams

- 1-8 1s set & cast 1 place, cross passing LSh & cast RSh round their 1st corner into centre ending BtoB (Lady facing up, Man down)
- 9-16 1L circle left with 2s & 1M with 3s, turn to face partner & set, 3/4 turn partner 2H to end facing 1st corners
- 17-24 1s turn 1st corner RH, partner LH, 2nd corner RH, partner LH & end facing 1st corners
- 25-32 1s dance Reel of 3 on opposite sides passing 1st corner LSh & cross RH to 2nd place own sides

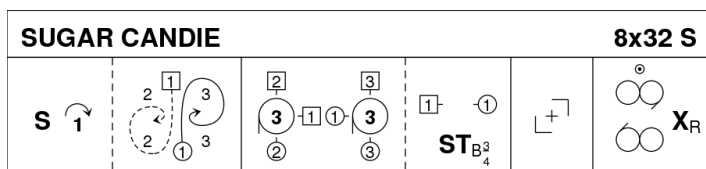

RSCDS Book 26

3C/4C longwise set.

4 INCHMICKERY J32 · 5/5L

Roy Goldring: 14 Social Dances for 2000 · Crib: MiniCrib · Diagram: Keith Rose's Diagrams

- 1-8 1s+2s circle 4H round to left, 1s dance in & cast to 3rd place
- 9-16 1s dance RH across (Lady with 3s & Man with 4s), pass RSh & dance LH across with other couple
- 17-24 1L+2M also 1M+5L turn RH, 1L+5M also 1M+2L turn LH (1s end 3rd place own side)
- 25-32 1s dance in & cast to 5th place, 5s+1s circle 4H round to right. 2 3 4 5 1

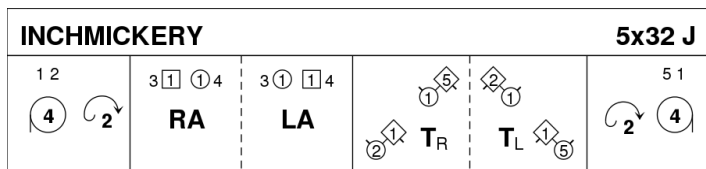

Roy Goldring, 2000, 14 Social Dances

5C/5C longwise set

5 BLOOMS OF BON ACCORD R32 · 4/4L

John Drewry: A Guide to Scottish Country Dancing · Crib: MiniCribs · Diagram: Keith Rose's Diagrams

- 1-8 All set & 1s+2s also 3s+4s dance RH across once round, 1s & 4s cast in 1 place to 2 1 (4)(3)
- 9-12 1s & 4s cross RH & cast to ends of set to meet partners in prom hold & dance into centre of dance
- 13-16 1s+4s dance round passing RSh & to end 1s in the middle on Men's side facing up & 4s in the middle on Ladies side facing down
- 17-24 All (1s & 4s in prom hold) dance reels of 3 on sides
- 25-28 4s+1s dance RH across in centre once round to end 4s facing up & 1s facing down
- 29-32 4s & 1s lead out of ends crossing & cast in 1 place to end 2 4 (1)(3)

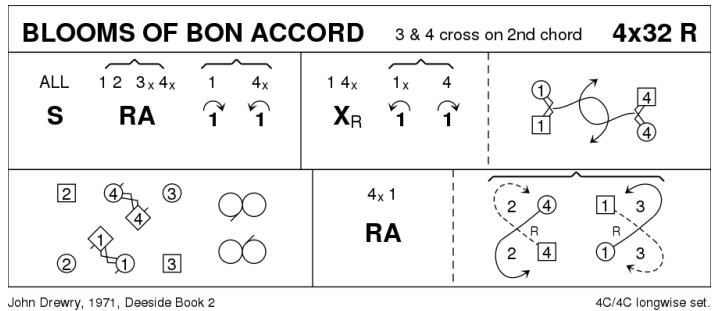

6 SANDS OF MORAR S32 · 3/4L

Barry Priddey: RSCDS XLV 6 · Crib: MiniCribs · Diagram: Keith Rose's Diagrams

- 1-8 1s dance Fig of 8 round 2s giving hands when possible
- 9-16 1s dance reflection reels of 3 on own sides (1s dance down between 2s to begin)
- 17-24 1s turn 2H & dance down middle to 3rd pl as 2s+3s continue reel & dance down behind 1s, all set & 1s followed by 2s+3s cast up to orig pls
- 25-32 1s+2s dance the Tourbillon :
1s & 2s turn partners 2H 1/2 way, 1M & 2L lead partners on 1 place clockwise to end 1s on Ladies side & 2s on Men's side, 1s set to 2s
1s & 2s 1/2 turn partners 2H, 1L & 2M lead partners on 1 place to end 2s in 1st pl & 1s in 2nd pl & 2s+1s cross RH to own sides

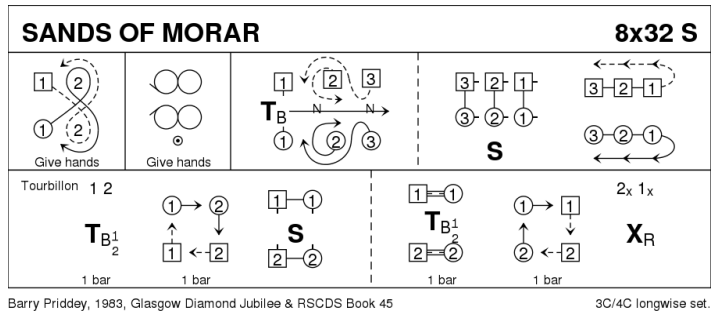

7 THE ROSELATH CROSS J32 · 3/4L

Henrietta Vosper: RSCDS XLI 10 · Crib: MiniCribs · Diagram: Keith Rose's Diagrams

- 1-8 1s+2s+3s dance reflection reels of 3 on sides (1s dance in & down to start) & end with 1s in 2nd pl BtoB facing own sides & 2s in 1st pl
- 9-16 2s+1s+3s set, 1s 1/4 turn to right & set with 2s+3s (as Crown Triangles), 1s dance RSh round RH crnr into middle BtoB facing opp sides
- 17-24 Repeat from new positions 1s ending in 2nd place own sides
- 25-32 1s dance reels of 3 across (Lady with 2s & Man with 3s)

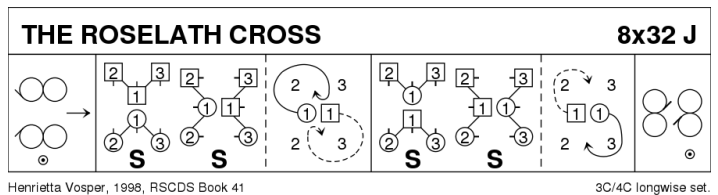

8 GLASTONBURY TOR R32 · 3/4L

Duncan Brown: RSCDS XLVII 11 · Crib: MiniCribs · Diagram: Keith Rose's Diagrams

- 1-8 1s+2s set & dance 1/2 RH across, 1s+3s set & dance 1/2 LH across
- 9-16 1s set & cross RH, 1s cast up 1 place & turn LH turn to face 1st corners
- 17-24 1s dance 1/2 reel of 4 with 1st crnr & pass left to face 2nd crnr, 1s dance 1/2 reel of 4 with 2nd crnr & curve right to end 1M between 3s & 1L btwn 2s
- 25-32 1M+3s also 1L +2s Set+Link for 3 once, 1s turn RH 1.1/2 times to 2nd place as 2s & 3s dance clockwise 1/2 way to places 2 1 3

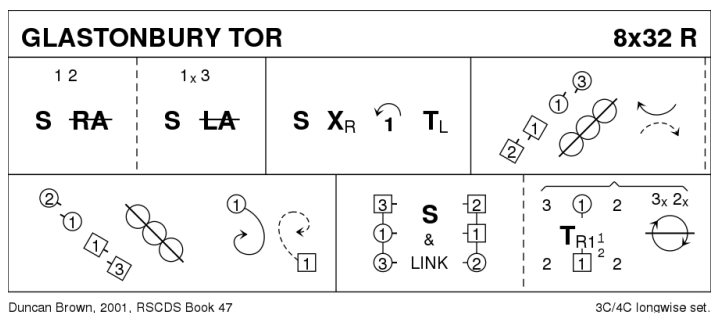

9 PROGRAMME ITEM – interval

10 SOUTH FROM OBAN J40 · 3/4L

Shirley M Shields: Leeds Branch Anniversary Book · Crib: MiniCrib

- 1-8** 1L+2L lead thru partners, cast back to place & pass RSh to change places & cross RH with opposite partner
- 9-16** 1M+2M repeat (2s at top)
- 17-24** 2s+1s dance RH across, 1s lead up & cast **while** 2s cast & lead up
- 25-32** 1s+3s dance LH across, 1s cast & lead up **while** 3s lead up & cast
- 33-40** 2s+1s+3s dance reel of 3 on sides (1s dancing out & up to begin)

11 THE SAILOR R32 · 3/4L

RSCDS XXIV 4 · Crib: MiniCrib · Diagram: Keith Rose's Diagrams

- 1-8** 1s cross down RH to face out between 2s & 3s giving hands to each corner & set, 1s cast round 1st corner to form lines of 3 across with 2s/3s & 2s+1s+3s set
- 9-16** 1s (turning to right) dance RSh reels of 3 across & 1s end passing LSh to 2nd place on opposite sides
- 17-24** 1s lead down for 2 bars & lead up, cross at the top & cast to 2nd place on own sides
- 25-32** 2s+1s dance R&L

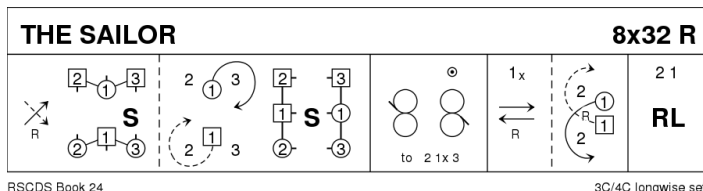

12 S-LOCOMOTION S32 · 4/4L

Ken Jones: RSCDS XLI 8 · Crib: MiniCrib · Diagram: Keith Rose's Diagrams

- 1-8** 1L+2L cross passing partner LSh & cast down 2 places as 3M+4M cross & cast up 2 places, top 4 Men also bottom 4 Ladies dance LH across.
- 9-16** 1M+2M cross passing opp dancer RSh & cast down 2 places as 3L+4L cross & cast up 2 places, top 2 cpls also bottom 2 cpls dance RH across.
- 17-24** 3s+4s+1s+2s dance 1/2 RSh reels of 4 on sides, 1s+4s+3s (bottom 3 couples) dance 1/2 reels of 3 on sides.
- 25-32** All set, cross RH, 2s+3s also 4s+1s circle 4H round to left.

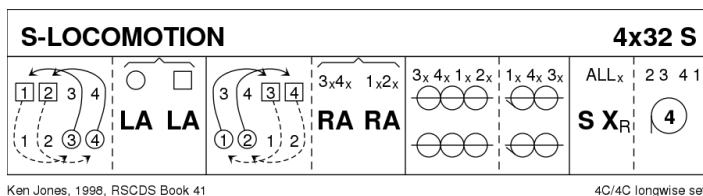

13 LINKS WITH ST PETERSBURG J32 · 3/4L

Malcolm Brown: RSCDS XLVI 10 · Crib: MiniCrib · Diagram: Keith Rose's Diagrams

- 1-8** 1s & 2s Set+Link ending 2s facing 1s NHJ, 2s & 1s Set+Link with partners to opposite sides. (2)(1)3
- 9-16** 1s followed by 2s dance down for 3 bars & change places with Lady dancing under Mans arm, 2s+1s dance up to 1st & 2nd places
- 17-24** 2M+1M turn LH as 2L+1L turn RH, 1M+3M turn RH as 1L+3L turn LH & 1s end facing 1st corners
- 25-32** 1s dance 'Hello-Goodbye' setting & petronella turn to 2nd place own sides

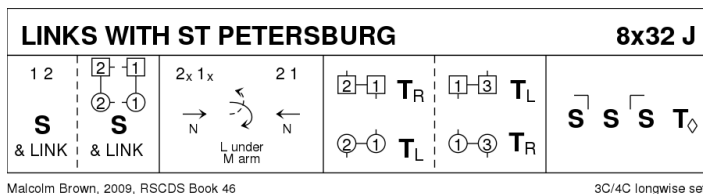

14 SHIFTIN' BOBBINS R32 · 3/4L

Roy Clowes: A Guide to Scottish Country Dancing · Crib: MiniCrib · Diagram: Keith Rose's Diagrams

- 1-8** 1s cross RH to double triangle position with 2s+3s & set, 1s cast up to top & dance down until they are between 2s & 3s
- 9-16** 1L dances RH across with 2M+3M **while** 1M dances LH across with 2L+3L, 1s followed by 2s+3s dance down centre
- 17-24** 3s followed by 2s+1s dance up & 3s+2s cast down to places, 1L dances LH across with 2M+3M **while** 1M dances RH across with 2L+3L
- 25-32** 1s dance up to top & cast down to 2nd place opposite side, 1s dance 1/2 Fig of 8 around 2s to end in 2nd place on own sides

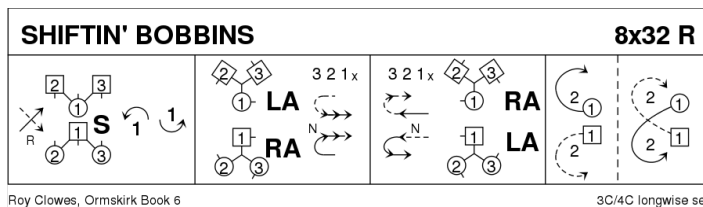

15 JACQUI WATSON'S STRATHSPEY S32 · 3/3L

Noel Watson: *The Leeds Golden Collection · Crib: MiniCribbs*

- 1-8** 1s+2s+3s set & 1s+2s dance RH across 1/2 way **while** 3s cross RH, all chase clockwise 1/2 way. 3 1 2
- 9-16** 2s dance reels of 3 across (2M up, 2L down) to end with 1s dancing to top **while** 3s cast to 2nd place
- 17-24** 1s dance reels of 3 on own sides casting to start. 1 3 2
- 25-34** 3 couple Set & Rotate:
25-28 1s+2s+3s Set & Rotate singly & chase clockwise to form lines of 3 across (Men facing down & Ladies up)
29-32 All change places with partner & chase clockwise to own sides to end 2 3 1

16 JOIE DE VIVRE J32 · 3/4L

Irene van Maarseveen: *RSCDS XXXIX 2 · Crib: MiniCribbs · Diagram: Keith Rose's Diagrams*

- 1-8** 1s set, cast 1 place, 1s dance down between 3s & cast back to 2nd place on own sides
- 9-16** 2s+1s+3s turn RH & chase 1/2 way round clockwise
- 17-24** 3s+1s+2s dance DoSiDo, set & 1/2 turn partners RH for Allemande
- 25-32** 3s+1s+2s dance Allemande

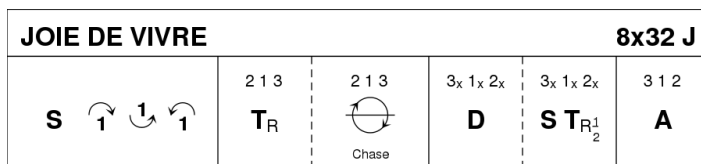

Irene van Maarseveen, 1996, RSCDS Book 39

3C/4C longwise set.

17 THE HIGHLAND RAMBLER R40 · 3/4L

Roy Goldring: *A Guide to Scottish Country Dancing · Crib: MiniCribbs · Diagram: Keith Rose's Diagrams*

- 1-8** 1s dance in & cast to 2nd place, dance RH across with 3s
- 9-16** 2s+1s dance LH across, 1L followed by partner cast up round 2L & dance down middle to 1L between 3s & 1M between 2s
- 17-24** 1s+2s+3s dance down the middle & back
- 25-32** 1M followed by partner cast down round 2L to 2nd places on own side & turn RH
- 33-40** 2s+1s+3s circle 6H round & back

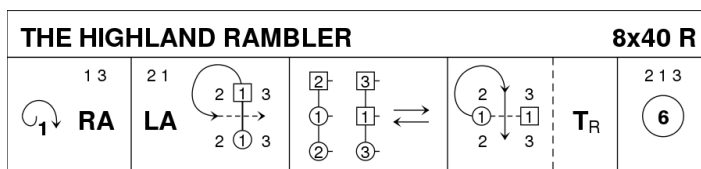

Roy Goldring, 1985, Leeds Silver Jubilee

3C/4C longwise set

18 PROGRAMME ITEM – extras

19 ROSNOR ABBEY J40 · 2/4L

Miss Milligan's *Miscellany of Scottish Country Dances · Crib: MiniCribbs · Diagram: SCDDDB Contributed Cribbs & Diagrams*

- 1-8** 1L+2M ¾ turn RH & set to each other (Man facing up & Lady down), 1L+2M turn 1/2 LH back to places & set
- 9-16** 1M+2L repeat above Fig
- 17-24** 1s lead down the middle & back ready for Allemande
- 25-32** 1s+2s dance Allemande
- 33-40** 2s+1s dance R&L

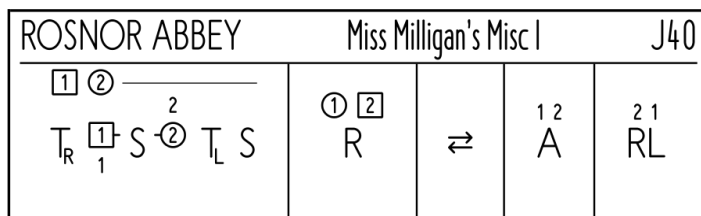

20 THE MINISTER ON THE LOCH S32 · 3/3L

Roy Goldring: *Magazine Dances 2005-2009 · Crib: MiniCribbs · Diagram: Keith Rose's Diagrams*

- 1-8** 1s+2s dance Diamond Poussette
- 9-16** 1s dance down for 2 steps, turn 2H, dance up to top & turn 2H
- 17-24** 1s+3s dance double Fig of 8 round 2s with 1s casting to start
- 25-32** 1M+2M turn LH 1.1/2 times **while** 1L+2L turn RH 1.1/2 times, 1M+3M turn RH 1.1/2 times **while** 1L+3L turn LH 1.1/2 times

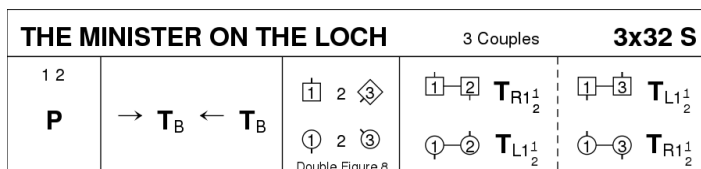

Roy Goldring, 24 Graded & Social Dances, RSCDS 4/2008

3C/3C longwise set.

21 SCOTT MEIKLE R32 · 4/4L

Alice McLean: RSCDS XLVI 3 · Crib: MiniCribs · Diagram: Keith Rose's Diagrams

- 1-8** 1s cross RH & cast to 2nd place, 1s dance 1/2 Fig of 8 round 2s
- 9-16** 1s+3s dance RH across, LH back
- 17-24** 1L followed by 3L dance Tandem reel of 3 across with 2s (LSh to 2M) & 1s end 3rd pl **while** 3M followed by 1M dance reel of 3 with 4s (LSh to 4L & 3s end in 2nd pl 2 3 1 4
- 25-32** 1s+4s dance 1/2 R&L, turn partners RH 1.1/2 times 2 3 4 1

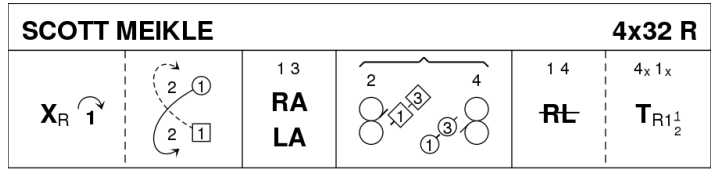

Alice McLean, Laurieston Collection 1, RSCDS Book 46

4C/4C longwise set.