

Leeds Club Dance 25 April 2015

LeedsClub Dance

St Chad's Parish Centre, 25th April 2015 at 7.30

Dancing to Phill Jones MC - Gerry Yates Members £10, Non members £11, Students £3

1 ROARING JELLY J32 · 3/4L

Hugh Foss: Glendarroch Scottish Dance Sheets · Crib: Eric Ferguson's SCD Cribs · Diagram: Keith Rose's Diagrams

- 1- 1c cross RH | cast off (2c up) ; cross RH, 1c casts R round 3c to finish in line across between 2c and 3c
- 9- Circle6 and back
- 17- 1c change places up/dn RH | Fig8 round 4c and 1c, start Rsh), finish on sideline facing 2c
- 25- 1c Reels3{6} on opposite sides (Rsh to 2c) | cross RH

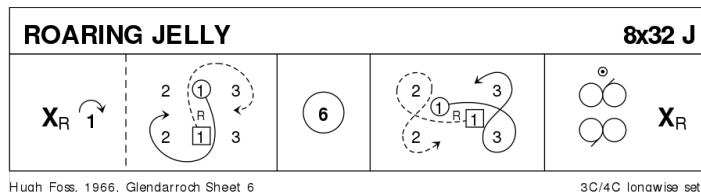

2 THE ROYAL YACHT BRITANNIA R40 · 3/4L

John Drewry: RSCDS XLIII 3 · Crib: Eric Ferguson's SCD Cribs · Diagram: Keith Rose's Diagrams

- 1- 1c set | dance (touch NH) out through 2pl (2c up) ; cast L round 4c into the middle for
- 9- Teapots R ; and L on the sides (1c+1c+2c RHA ; 1c+3c+4c LHA), face 1c
- 17- set to 1c | 1c dance (Sk-Ch) ¾ R round P to face 2c ; set to 2c | dance (Sk-Ch) R round P to face out in 2pl
- 25- Rsh Reels3 on the sides
- 33- 2c+1c+3c circle6 and back.

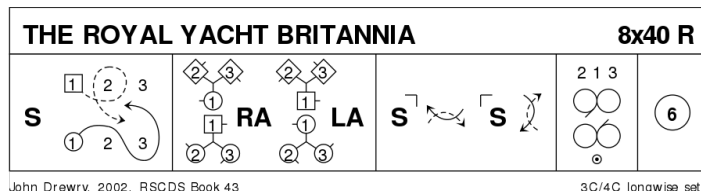

3 SUGAR CANDIE S32 · 3/4L

RSCDS XXVI 9 · Crib: Eric Ferguson's SCD Cribs · Diagram: Keith Rose's Diagrams

- 1- 1c set | cast off (2c up), pass Lsh and cast R round 1c, to finish BtoB in the centre, M facing down, W up
- 9- 1W+2c & 1M+3c circle3, at end 1c swivels R to face P ; 1c set, turn ¾ BH to face 1c (open out with 1M using RH to assist P)
- 17- Turn CPCP
- 25- Reels3{6} with corners, Lsh to 1c, 1c cross RH to (2,1,3)

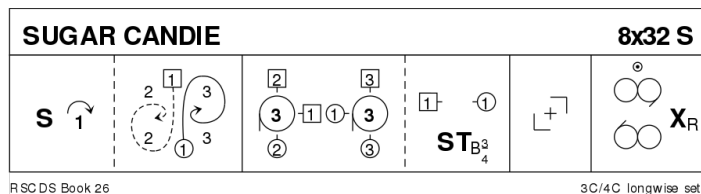

4 THE DANCING MAN R32 · 3/4L

Roy Goldring: A Second Book of Graded Scottish Country Dances · Crib: Eric Ferguson's SCD Cribs · Diagram: Keith Rose's Diagrams

- 1- 1c+2c turn RH to places ; 1c+2c RHA (1,2,3)
- 9- Parallel RshReels3 on the sides, but 1c+2c extend reel to form line across (2M, 1M, 2W, 1W), 3c ends in 3pl
- 17- 1c+2c ¾ Reel4 across (2W,2M,1W,1M)| pass P Rsh to own side (2,1,3)
- 25- Circle6 and back

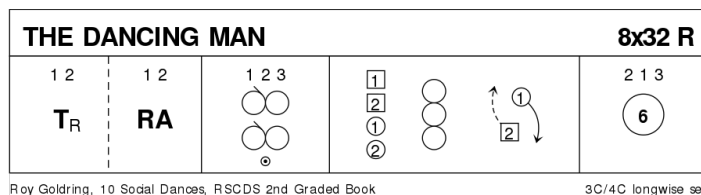

5 JOHNNIE WALKER M128 · 4S

Norman & Helen Robson: *The Whisky Collection* · Crib: Eric Ferguson's *SCD Cribs* · Diagram: Keith Rose's *Diagrams*

Strathspey

- 1- Circle8 and back
- 9- Set to and turn corners RH ; set to and turn P LH
- 17- 1c+3c advance & meet opposite person {1}, lead out between side couple, cross and dance to opposite place ; turn P 1½ RH (3,2,1,4)
- 25- 2c+4c repeat (to 3,4,1,2)
- 33- All W Petronella Turn into next W place to the R | All set ; repeat to W in original places
- 41- All M repeat Petronella Turns and setting back to original places
- 49- G-Chain (one step per hand)
- 57- Promenade (Allemande hold) cclw round the set, to places

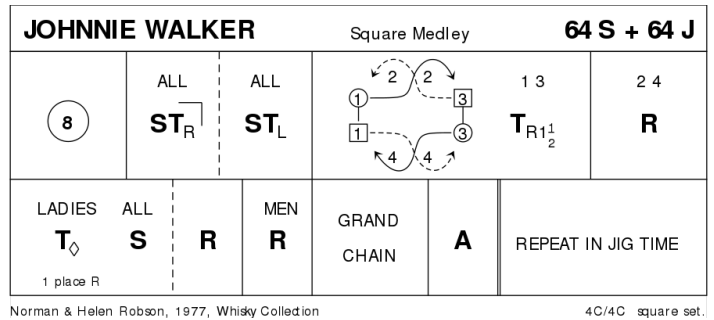

Jig

- 65-128 Repeat all, end with women in the centre facing P for bow/curtsey.

6 JOE MACDIARMID'S JIG J32 · 4/4L

Joan Richards: *RSCDS Leaflets 2014 44* · Crib: Eric Ferguson's *SCD Cribs* · Diagram: Keith Rose's *Diagrams*

- 1- All A&R ; turn P RH, finish with 1c facing 4c in the middle NHJ
- 9- 1c+4c A&R up/down, finish as started ; 1c turn 2c & 4c turn 3c on the sides EH (start between them) (to 1,2,3,4)
- 17- 1c lead down the centre, cross below 3c, cast behind 4c ; ½ Fig8 up round 4c (2c+3c+4c up) (2,3,4,1)
- 25- All Circle8 and back

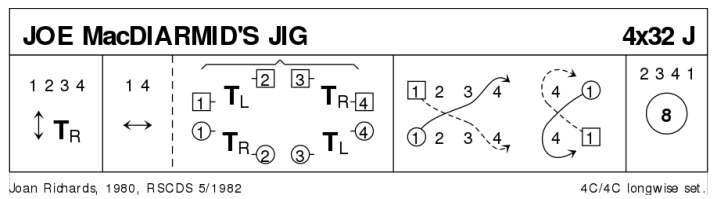

7 THE NEW RIGGED SHIP J48 · 3/4L

RSCDS IX 7 · Crib: Eric Ferguson's *SCD Cribs* · Diagram: Keith Rose's *Diagrams*

- 1- 1c+2c circle4 and back
- 9- 1c+2c+3c Rsh Reels3 on the sides
- 17- 1c lead down the middle and up (1,2,3)
- 25- 1c cross RH, cast off {3}, cross LH, cast off {3} | lead up
- 33- 1c cast off to face 1cnr (2c up) | set to 1cnr | to 2cnr
- 41- 2c+1c+3c Reels3{6} (Rsh to 2cnr) on the sides | 1c cross (2,1,3)

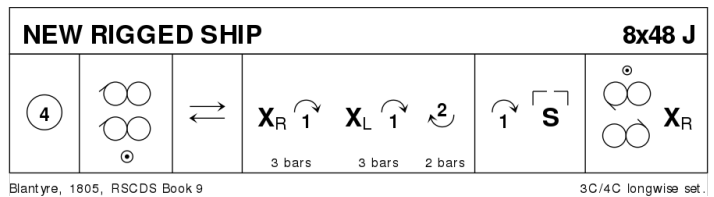

Note on 9-16: TACnotes says Rsh reels ; Foss in »Sundry writings anent SCD« says historically they were mirror reels

8 THE SINGING SANDS S32 · 3/3L

Barry Priddey: *The Silver Rose Book of Scottish Country Dances* · Crib: Eric Ferguson's *SCD Cribs* · Diagram: Keith Rose's *Diagrams*

- 1- 1c+2c Tourbillon (1c+2c turn P BH ½, opening out to one place clw in the square (1c to W side, 2c to M side) | 1c set to 2c ; repeat figure (to 2x,1x) | 2c+1c cross RH) (2,1,3)
- 9- 1c (M up, W down) dances ½ Fig8 Rsh round 2cnr ; 1M+3c & 1W+2c ½ Rsh reels3 across (2x,1,3x)
- 17- Diagonal R&L (to 3,1,2)
- 25- All set | 3c+1c ½ RHA while{} 2c cross RH ; all chase clw ½ round (2,3,1)

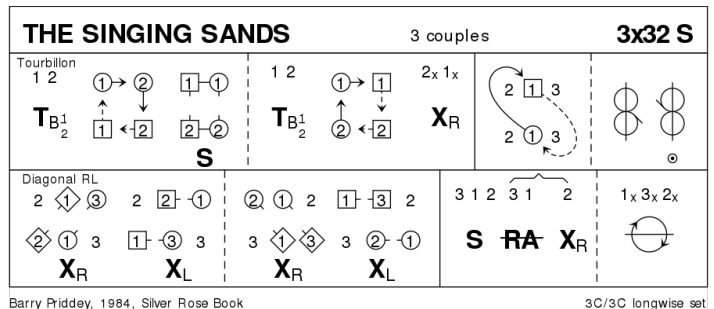

Note: The dry white sands on the north-west side of the Isle of Eigg are said to produce a musical sound when walked upon.

9 BACK TO THE FIRESIDE R32 · 3/4L

Roy Goldring: RSCDS XXXVIII 4 · Crib: Eric Ferguson's SCD Crib · Diagram: Keith Rose's Diagrams

- 1- 3c followed by 1c dance down the middle | set ; dance up the middle, 1c cast off to 3pl **while**{2} 3c dance up to 1pl (3,2,1)
- 9- »pick-up chain«, from below: 1c cross RH, 1c+2c change places LH ; 1c+3c change places RH **while** {2} 2c cross RH ; 1c cross LH **while**{2} 3c+2c change places LH (to 1, 2x, 3)
- 17- 1c+2c set advancing to join NH in a circle | releasing hands, 1c+2c Petronella one place R ; Set NHJ | repeat petronella, to sidelines (2,1x,3)
- 25- 1c ½ Fig8 L (W up, M down) ; All turn RH (2,1,3)

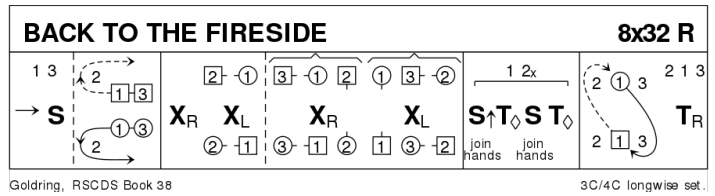

10 PROGRAMME ITEM – interval

11 WELCOME TO AYR J32 · 3/4L

Jill Hendricksen/Kathy Stewart: RSCDS XLVII 8 · Crib: Eric Ferguson's SCD Crib · Diagram: Keith Rose's Diagrams

- 1- 1c+2c DbIFig8, 1c crossing down to start, at end 2c face out
- 9- 1c+2c turn EH 1¼ on side (2c to 1pl) and 1c face down NHJ ; 1c dance down and turn 3c EH, 3c finish in 3pl and 1c facing 1cnr
- 17- 1c+1cnrs ½ diag. Reel4 and pass Rsh ; repeat with 2cnrs, 1c finish on midline Lsh to Lsh facing own side
- 25- 3c+1M & 1W+2c RHA (3x,1x,2x) ; All chase clw ½ round (2,1,3)

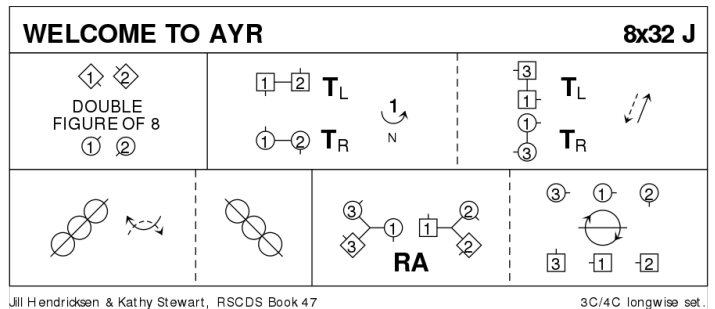

12 PROGRAMME ITEM – Golden Eccles Cake

13 JAMES SENIOR OF ST ANDREWS S32 · 4/4L

Jenny Bradley: RSCDS XLII 8 · Crib: Eric Ferguson's SCD Crib · Diagram: Keith Rose's Diagrams

On 2nd chord, 3c+4c cross to opposite side (1,2,3x,4x)

- 1- 1c+4c turn RH | cast to middle (2c & 3c step to end) ; 1c+4c ½ Fig8 round end couple (2,1x,4,3x)
- 9- 1W+4M & 1M+4W, in promhold (W on the L) ½Reels3 across with the end C on their R (Lsh to 2M & 3M) ; continue into ½ Lsh Reels3 with the other end couple (to 2,1x,4,3x)
- 17- 2W+1W & 4W+3W turn RH ½ to face each other, twirl R and dance to exchanged places **while**{2} 2M+1M & 4M+3M dance clw round them to exchanged places ; 1M+2M & 3M+4M turn RH ½ to face each other | twirl R and dance to exchanged places **while**{2} 1W+2W & 3W+4W dance clw round them to exchanged places (2,1x,4,3x)
- 25- 1c+4c S&Link ; circle4 L (to 2,4,1x,3x)

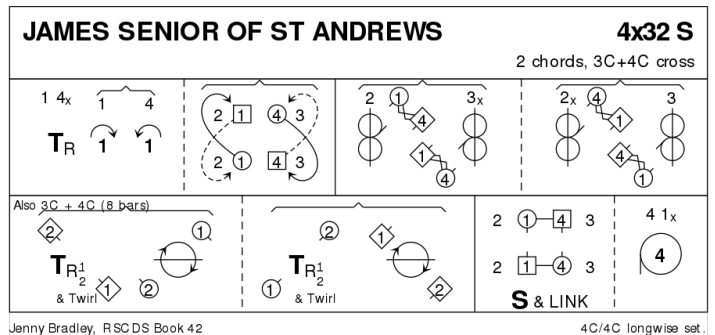

14 THE BLACK BLACK OIL R32 · 5/5L

John Drewry: Deeside Book Part 2 · Crib: Eric Ferguson's SCD Crib · Diagram: Keith Rose's Diagrams

- 1- 1c & 3c ½ RH turn moving down 1 place (2c & 4c up) and set ; cross LH and cast left 1 place to face 1cnr (1M & 3W passing Lsh between 4c)
- 9- 1W+2c & 1M+4c+3W Rsh & 3M+5c Rsh Reels3/4/3 across (1M+3W finish Rsh), at end 1c+3c join RH to 1cnr and LH to P
- 17- BiL | ½ turn 1cnr RH ; BiL | ½ turn 1cnr RH and face 2cnr
- 25- '2cnrs pass & turn' (pass 2cnr no hands, corners Turn RH, pass back) ; 1c & 3c 1½ RH turn to own side and cast off 1 place (4c+5c up) (2,4,1,5,3)

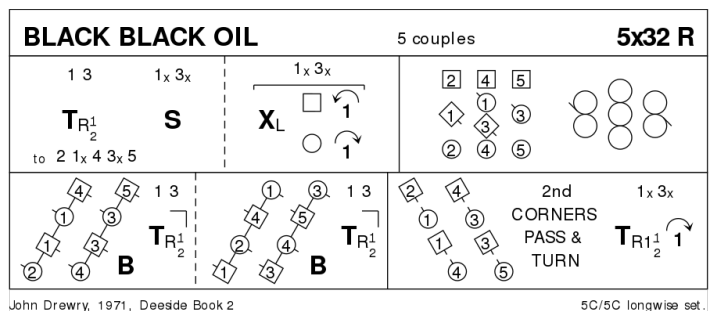

Can also be danced as a 3C or 7C or .. dance, always reels of 3 at both ends, reels of 4 in the middle

15 LIQUID ASSETS J32 · 3/4L

John Drewry: *Stoneywood Collection Volume 2 · Crib: Eric Ferguson's SCD Cribbs*

- 1-- 1c cross down into Mirror Reels3 on opposite side (1x,2,3), 2c facing out
- 9-- 1c turn 2c on sideline EH 1½ (2,1x,3) ; 1c+3c repeat (2,3,1x), 3c facing out
- 17-- 1c cross up into Mirror Reels3 on own side (2,3,1), 3c facing out
- 25-- 1c turn 3c on sideline EH 1½ (2,1,3) ; 1c dance up between 2c and cast off to (2,1,3)

16 ALISON ROSE S32 · 4/4L

Derek Ivory: *Imperial Book of Scottish Country Dances – Volumes 1–3 · Crib: Eric Ferguson's SCD Cribbs · Diagram: Keith Rose's Diagrams*

- 1-- 1c lead down the middle and loop up into 4pl (2c+3c+4c up) ; all set | Circle8 L for two places
- 9-- all M (at top) LHA **while**{4} all W (below) RHA ; Continue both HA, but as each couple meets (order 1,4,3,2) they cross to the other wheel (W pass in front)
- 17-- As couples meet again the W join RH with P, the M dancing as if still in RHA, and (1c leading) unwind and lead up the middle and out to opposite sidelines {6} | all turn P RH ½ into
- 25-- 1c+4c+3c+2c Allemande (to 2,3,4,1)

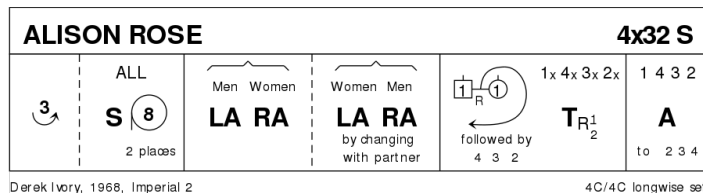

»Easier version« for [17-20]: As couples meet the W join NH with P who maintain RHA (continue as described)

17 QUARRIES' JIG J32 · 3/4L

Kent W Smith: *RSCDS XXXVI 3 · Crib: Eric Ferguson's SCD Cribbs · Diagram: Keith Rose's Diagrams*

- 1-- 1c set | cast (2c up) ; ½ Fig8 Lsh round 1cnr (2,1x,3)
- 9-- 1M+2c and 1W+3c Lsh Reels3 across, at end 1c LH turn to face 1cnr
- 17-- 1c+1cnrs change places RH **while**{2} 2cnrs set | centre dancers change places LH **while**{2} the others chase clw one position ; repeat from new positions
- 25-- Repeat from new positions, but to finish 1c turn LH to 2plx ; 2c+1c+3c set | 1c cross RH.

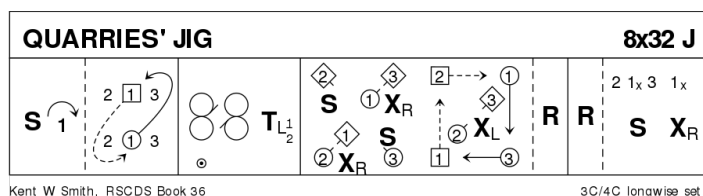

18 THE PEAT FIRE FLAME R40 · 3/4L

John Drewry: *Dances Of An Island Clan · Crib: Eric Ferguson's SCD Cribbs · Diagram: Keith Rose's Diagrams*

- 1-- 1c cast off (2c up) | 1c ½Fig8 between 2c | 1c turn LH to 1cnr.
- 9-- 1c turn 1cnr RH | pass Rsh ; turn 2cnr LH | pass Lsh to face 1cnr.
- 17-- ½Reel4 with 1cnrs, pass Lsh ; ½Reel4 with 2cnrs, finishing facing 3cnr (1cnr person)
- 25-- 1c set to 3cnr, 1c spiral Rsh round each other (skip change !) ; 1c set to 4cnr (2cnr person) spiral Rsh as before to face out in 2plx.
- 33-- 1c cast R and meet in the middle **while**{4} corners ½R&L (no polite turns) ; all turn RH (1c remains facing out on 1st turn) (2,1,3)

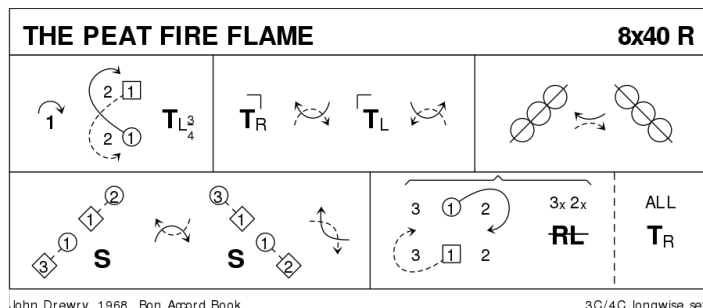

19 PROGRAMME ITEM – extras

20 THE SAILOR R32 · 3/4L

RSCDS XXIV 4 · Crib: Eric Ferguson's SCD Cribbs · Diagram: Keith Rose's Diagrams

- 1-- 1c cross down RH (2c up) to 2plx and BiL with cnrs ; 1c cast R into lines across | all set
- 9-- All Reels3 across,Rsh to 1cnr, finishing (2,1x,3)
- 17-- 1c lead down | lead to the top ; cross and cast to (2,1,3)
- 25-- 2c+1c R&L.

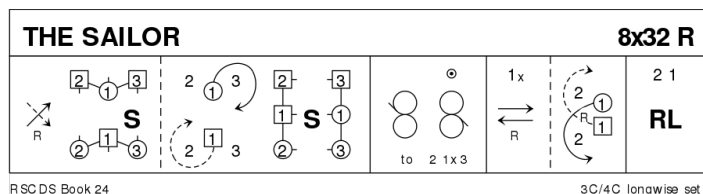

Note: [3-4] is NOT in DTr position.

21 MRS STEWART'S JIG J32 · 3/4L

Frans Ligtmans: RSCDS XXXV 1 · Crib: Eric Ferguson's SCD Cribbs · Diagram: Keith Rose's Diagrams

- 1- 1c set | 1W casts, 1M following, round 3W, 1W dances up round 3M and 1M dances up the middle, 1c face 3c (2c up on 7-8) (2,1x,3)
- 9- 2c+1c+3c G-Chain (2c cross), 2M+1M finish facing out
- 17- 2c+1c L-Chain
- 25- 2c+1c+3c A&R ; 1c turn RH 1½ to (2,1,3)

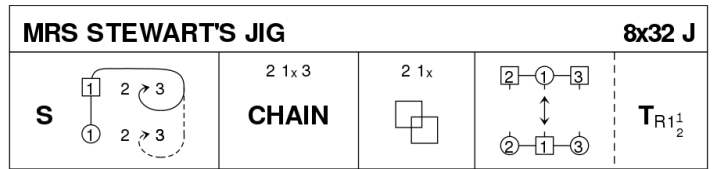

Frans Ligtmans, 1986, RSCDS Book 35

3C/4C longwise set.

22 THE BYRON STRATHSPEY S32 · 3/3L

John Drewry: Deeside Book Part 2 · Crib: Eric Ferguson's SCD Cribbs · Diagram: Keith Rose's Diagrams

- 1- 1c+2c+3c Petronella Turn into midline, set ; all turn P BH 1¼ to (1,2,3)
- 9- "Teapots": 1c+2W & 2M+3c RHA ; 1c+2M & 2W+3c LHA , to (1,2,3) with 1c facing out and 2c facing up in promhold
- 17- 2c (promhold) +1W+1M Reel3 across (Rsh to 1W), at end all dance in for
- 25- 2c+1c+3c Allemande (to 3,1,2).

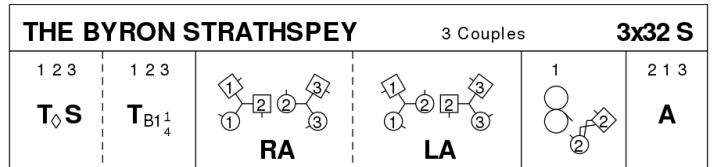

John Drewry, 1975, Deeside Book 2

3C/3C longwise set.