

Leeds Club Dance 27th Sept 2014

Leeds Scottish Country Dance Club Dance

Cookridge Village Hall, 27th September 2014 7.00

Dancing to CDs MC - Gerry Yates A Tribute to John Drewry

1 LIQUID ASSETS J32 · 3/4L

John Drewry: *Stoneywood Collection Volume 2 · Crib: Eric Ferguson's SCD Cribs*

- 1-- 1c cross down into Mirror Reels3 on opposite side (1x,2,3), 2c facing out
- 9-- 1c turn 2c on sideline EH 1½ (2,1x,3) ; 1c+3c repeat (2,3,1x), 3c facing out
- 17-- 1c cross up into Mirror Reels3 on own side (2,3,1), 3c facing out
- 25-- 1c turn 3c on sideline EH 1½ (2,1,3) ; 1c dance up between 2c and cast off to (2,1,3)

2 THE EARL OF MANSFIELD R48 · 4/4L

John Drewry: *The Leaflet Dances with Music · Crib: Eric Ferguson's SCD Cribs · Diagram: Keith Rose's Diagrams*

- 1- 1c+2c circle4 and back
- 9- 1c face 2c & 3c face 4c, all set | change places RH ; all set | change back RH (2M+4M face out and up) (1,2,3,4)
- 17- 1M+2c & 3M+4c Lsh Reels3 across, the M taking P in promhold on [20] ; 1c+3c finish on M side in promhold facing in and down
- 25- 3c with 1c following dance between 4c, divide & cast up ; 3c cross up between 2c and cast to 3pl (2c up) **while**{4} 1c dance on up and turn LH to face 1cnr
- 33- 1c turn 1cnrs RH, pass Rsh (cnrs dance 4 bars) ; 1c turn 2cnrs LH, to 2pl facing up NHJ (2,13,4)
- 41- 1M+2M+3M LHA **while**{ 1W+2W+3W RHA ; 1c breaks to dance down NHJ and 3c follows into ; 1M+3M+4M RHA **while**{ 1W+3W+4W LHA (to 2,3,4,1)

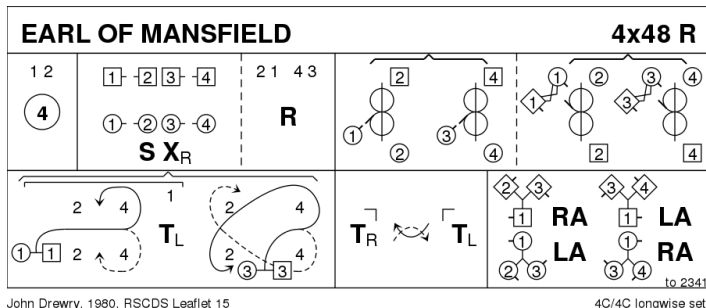

John Drewry, 1980, RSCDS Leaflet 15

4C/4C longwise set.

3 FOXHILL COURT S32 · 3/4L

John Drewry: *The Canadian Book of Scottish Country Dances · Crib: Eric Ferguson's SCD Cribs · Diagram: Keith Rose's Diagrams*

- 1- 1c & 2c Espagnole, 1c end facing 1cnr (2,1,3)
- 9-20 Dance to Each Corner and Set (»Free« cnrs set **while**{ Centre couple change place Rsh with the cnrs, who then pass each other Rsh to face next cnr on R | repeat this five times (on alternating diagonals) to finish 1c facing 3cnr position)
- 21-24 1c+1cnr {3cnr pos} turn ¾ BH, opening up to face diagonally across the set with 1cnr on the R, and set **while**{ 2cnrs set diagonally and cross RH
- 25- 1c+1cnr A&R diagonally ; 1c+1cnrs ¾ RHA (to 2,1,3)

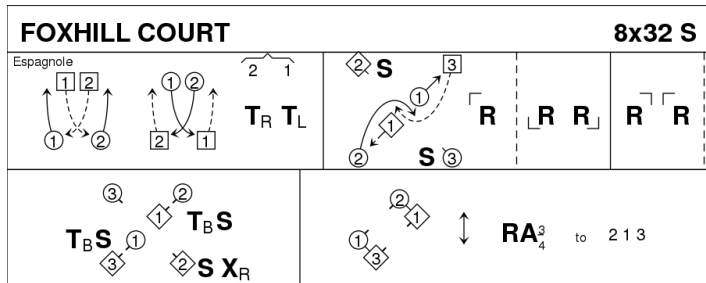

John Drewry, Canadian Collection

3C/4C longwise set.

4 RAMADAN-CE R32 · 3/4L

John Drewry: *The Turkish Set · Crib: Eric Ferguson's SCD Cribs · Diagram: Keith Rose's Diagrams*

- 1- 1c+2c+3c Inveran Reels (1,2,3)
- 9- 1c cross RH | cast (2c up) ; Turn RH to face 1cnr
- 17- 1c cast R round 1cnr, pass Rsh in the middle ; cast Rsh round 2cnr to 2plx **while**{8} 1cnrs turn RH ½, twirl R and dance out to exchanged places ; 2cnr repeat (3x,1x,2x)
- 25- ½ Reels3 across, 1c Lsh to 3cnr ; ½ Reels3 on the sides, 1c Rsh to 4cnr (2,1,3)

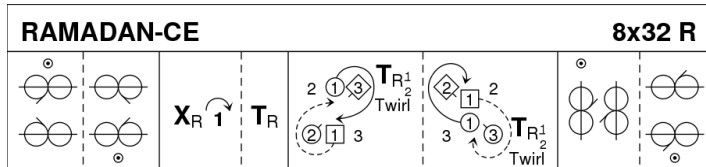

John Drewry, 2000, Turkish Set

3C/4C longwise set

5 ANNA HOLDEN'S STRATHSPEY S32 · 2/4L

John Drewry: RSCDS XLII 2 · Crib: Eric Ferguson's SCD Cribs · Diagram: Keith Rose's Diagrams

- 1- 1c+2c RHA (2c face out) ; 1c cross down, **while**{2} 2c cast up | 1M+2W & 2M+1W Turn ¾ easy hand to line4 across facing down (1c between 2c)
- 9- All dance down, on [12] 1c turns in and 2c meets, all NHJ ; 1c+2c dance up | 1c cast off to 2plx, **while**{2} 2c dance to 1pl (loop is usual)
- 17- All set | »petronella in tandem« ; repeat (to 1,2x)
- 25- All set | ½ Circle4 Left ; 1c turn BH 1½ to 2pl.

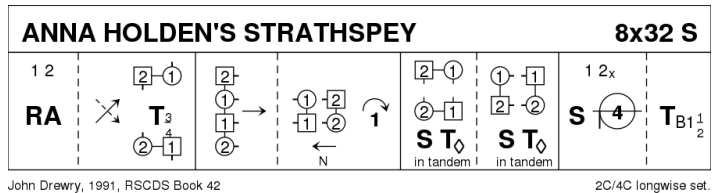

6 MIDNIGHT OIL J48 · 5/5L

John Drewry: Bankhead Book Part 3 · Crib: Eric Ferguson's SCD Cribs · Diagram: Keith Rose's Diagrams

- 1- 1c+3c lead down | turn ¾ RH and face P, retaining hands (2c+4c up) ; set, W turning under M's arm | 1c+3c dance up (W leading)
- 9- 1c+2W & 3c+4W RHA ; 1c+4M & 3c+5M LHA, 1c+3c finish facing 1cnrs
- 17- 1c+3c with 1cnrs pass and turn ; then with 2cnrs, at end pass Rsh onto midline, W above and facing M
- 25- Reel4 on midline, at end pass Rsh to finish 1c/3c facing out to W/M side
- 33- 1c dance out between 2W & 4W, split, cast round them, meet in middle, repeat through M side **while**{3c do the same, starting between 4M & 5M. All finish where they started the reel, but 1M faces 3W
- 41- 1W+3M set twice facing up and down **while**{1M+3W turn RH to face P ; 1c+3c turn P LH ¾ | cast off on own side (4c+5c up) (2,4,1,5,3)}

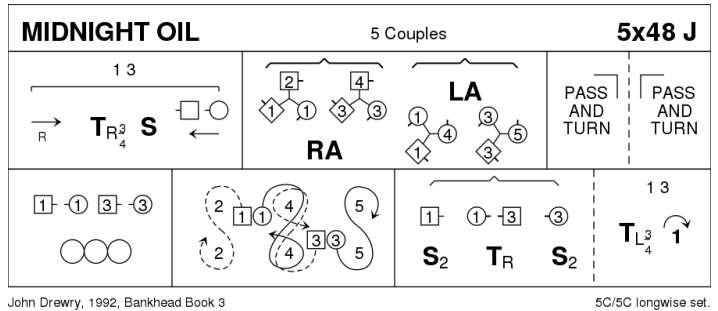

7 MRS MACPHERSON OF INVERAN R32 · 3/4L

John Drewry: A Guide to Scottish Country Dancing · Crib: Eric Ferguson's SCD Cribs · Diagram: Keith Rose's Diagrams

- 1- 1c+2c+3c Inveran Reels3 (1c crossing top and bottom)
- 9- 1c turn RH 1½ into 2plx facing out (2c up) ; 1c cast up round 2c and cross down to (2,1,3)
- 17- G-Chain (2c cross)
- 25- circle6 and back

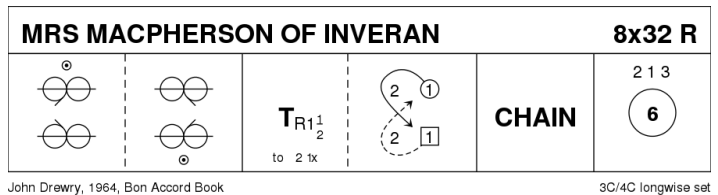

8 INTERVAL

9 MAJOR IAN STEWART J32 · 3/4L

John Drewry: RSCDS XXXV 4 · Crib: Eric Ferguson's SCD Cribs · Diagram: Keith Rose's Diagrams

- 1- 1c+2c turn RH ½ into | ½ RHA into ; 2c+1c turn RH, 2c finish facing out (2,1,3)
- 9- Opposing Reels3 on own sides (1c inwards, Rsh to 4cnr) 1c finish facing 1cnr, 2c+3c finish with loops
- 17- SetH&G to (2,1,3)
- 25- Circle6 L {3}, cross R foot over L and chase back cclw to (2,1,3)

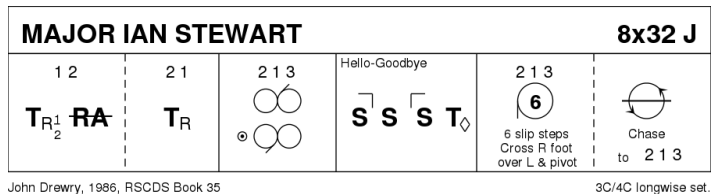

10 BRATACH BANA R32 · 3/4L

John Drewry: *Bon Accord Book of Scottish Country Dances · Crib: Eric Ferguson's SCD Cribbs · Diagram: Keith Rose's Diagrams*

- 1- 1c turn RH | cast off (2c up) ; ½ Fig8 to R around 1cnr (to 2,1x,3)
- 9- ½Reel3 on sides (Rsh to 2cnr) ; ½Reel3 across (Lsh to 3cnr position), finish on sides (3x,1,2x)
- 17- 1c turn ¾ LH, Turn 1cnr person (3cnr position) RH ; pass Rsh, turn 2cnr person (4cnr position) ¾ RH to promhold (cnr on the right)
- 25- These pairs change places Rsh | drop left hand and turn RH ½ to sidelines ; half diagonal R&L (1st diagonal direction)

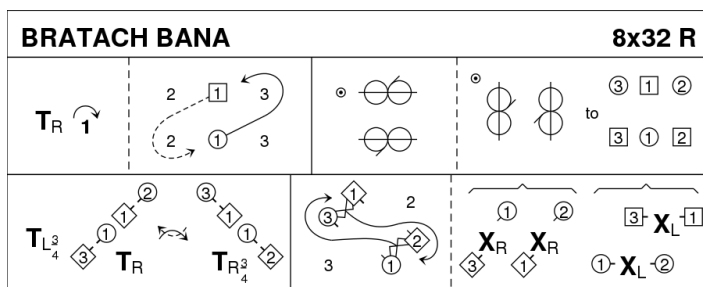

John Drewry, *Bon Accord Book*

3C/4C longwise set

Note on [27-28]: originally 2 PdB. modified by Drewry to SkCh. O. Otto says best variant is corners in PdB, 1c in SkCh

11 THE BELLE OF BON ACCORD S32 · 4/4L

John Drewry: *A Guide to Scottish Country Dancing · Crib: Eric Ferguson's SCD Cribbs · Diagram: Keith Rose's Diagrams*

- 1- 1M cross, cast off round 2W to finish in the middle facing up while{4} 1W crosses between 2M and 3M, casts up to the middle facing down while{4} 3c do the same round 4c (2c & 4c step up ½ place) ; 1c+2c & 3c+4c RHA
- 9- 1c+3c Reel4 in the centre of the dance
- 17- 1c+3c turn ¾ RH to finish facing up NHJ while{2} 2c & 4c dance up one place and in to face down NHJ. All set ; 2c+1c & 4c+3c circle4 L (to sidelines 2,1x,4,3x)
- 25- 1c/3c lead up & cross between 2c/4c and cast off one ; 1c+3c turn BH, opening to face down | 1c dance to 4pl while{2} 3c cast up to 2pl. (2,3,4,1)

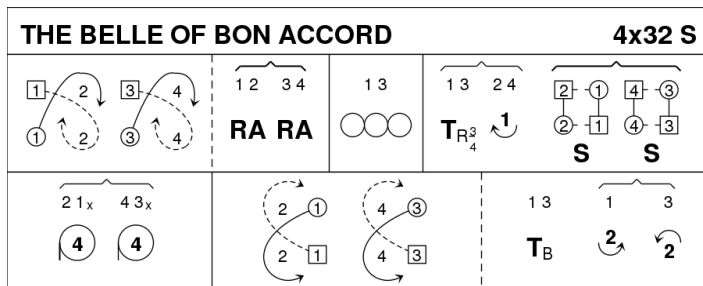

John Drewry, 1981, *Deeside Book 2*

4C/4C longwise set.

12 THE BLACK BLACK OIL R32 · 5/5L

John Drewry: *Deeside Book Part 2 · Crib: Eric Ferguson's SCD Cribbs · Diagram: Keith Rose's Diagrams*

- 1- 1c & 3c ½ RH turn moving down 1 place (2c & 4c up) and set ; cross LH and cast left 1 place to face 1cnr (1M & 3W passing Lsh between 4c)
- 9- 1W+2c & 1M+4c+3W Rsh & 3M+5c Rsh Reels3/4/3 across (1M+3W finish Rsh), at end 1c+3c join RH to 1cnr and LH to P
- 17- BiL | ½ turn 1cnr RH ; BiL | ½ turn 1cnr RH and face 2cnr
- 25- '2cnrs pass & turn' (pass 2cnr no hands, corners Turn RH, pass back) ; 1c & 3c 1½ RH turn to own side and cast off 1 place (4c+5c up) (2,4,1,5,3)

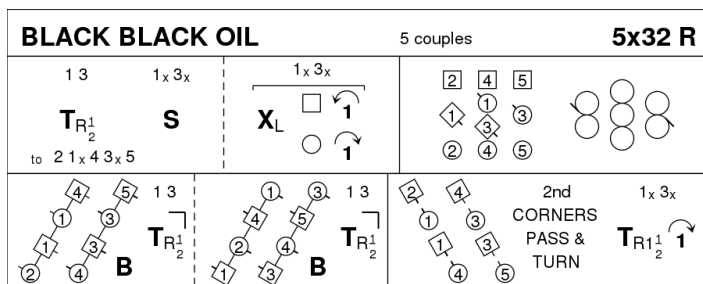

John Drewry, 1971, *Deeside Book 2*

5C/5C longwise set.

Can also be danced as a 3C or 7C or .. dance, always reels of 3 at both ends, reels of 4 in the middle

13 THE MORAY RANT S48 · 3/3L

John Drewry: *Silver City Book of SCD · Crib: Eric Ferguson's SCD Cribbs · Diagram: Keith Rose's Diagrams*

- 1- Inveran reels{6} (1c cross down from top, cross up from bottom) | 1c cross RH to (1x,2,3)
- 9- 1c set advancing | turn BH ; dance down between 2c, cast behind 3c, finish BtoB between 3c facing opp. side
- 17- 1M+3W & 1W+3M set & turn EH ¾ (1c start out between 2c and 3c) ; 1c dance up, cast up behind 2c, finish BtoB between 2c facing opp. side
- 25- 1M+2W & 1W+2M set & turn EH ¾ (1c start out between 2c and 3c) ; 1c ½Fig8 round 2c to (1,2,3)
- 33- 1c+2c Circle4 L ; 1c facing 2c NHJ set and 1c face up | 1c cast off while{2} 2c lead up (2,1,3)
- 41- 1c+3c repeat [33-40] to (2,3,1)

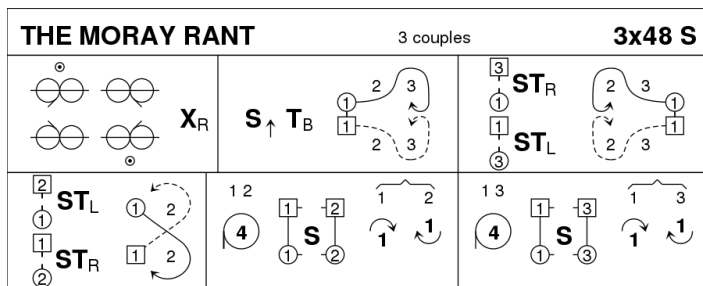

John Drewry, 1968, *Silver City*

3C/3C longwise set.

14 BLOOMS OF BON ACCORD R32 · 4/4L

John Drewry: A Guide to Scottish Country Dancing · Crib: Eric Ferguson's SCD Cribbs · Diagram: Keith Rose's Diagrams

3c+4c cross on 2nd chord(1,2,3x,4x). This dance has top/bottom symmetry

- 1- All C set | 1c+2c & 3c+4c RHA | 1c & 4c cast in to 2pl/3pl **while**{2} 2c+3c lead out to end places
- 9- 1c+4c cross RH, cast to ends, meet in promhold and dance in between end couples, curve round the other couple Rsh to finish 1c / 4c on M/W side facing out and right
- 17- 1c & 4c (in promhold) Rsh Reels3 with the »corners« on M/W sides, at end meet in the centre
- 25- 4c+1c RHA, at end M swivels right so couples face ends of set (1c down, 4c up, W on P's left, RHJ) ; 4c&1c cross down between end couples and cast in to 3pl/2pl (to 2,4,1x,3x)

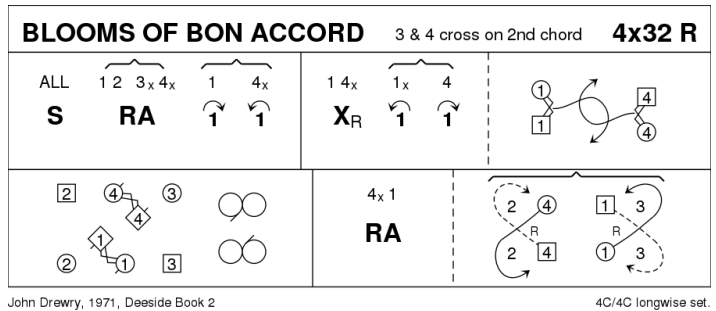

15 THE HAZEL TREE J32 · 3/4L

John Drewry: Summer Collection, Set 5 · Crib: Eric Ferguson's SCD Cribbs · Diagram: Keith Rose's Diagrams

- 1- 1c+2c Espagnole, 1c finishing facing 1cnr
- 9- 1c turn 1cnr RH, pass Rsh ; turn 3cnr LH, pass Lsh (cnrs dance for {4})
- 17- Turn 2cnr RH, pass Rsh ; turn 4cnr LH, pass Lsh to 2plx side by side facing down
- 25- Lead LHJ between 3c, cross and cast to 2pl ; All C turn RH

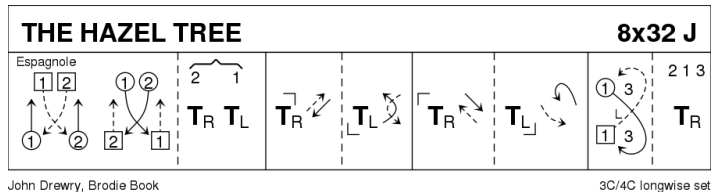

Espagnole: both W lead RHJ to M side, cross and cast back to exchanged places while{} Men cross to W side, lead RHJ back to M side and cross to exchanged places ; all turn P EH (2,1)

16 INVERNEILL HOUSE R32 · 3/4L

John Drewry: RSCDS XXXV 2 · Crib: Eric Ferguson's SCD Cribbs · Diagram: Keith Rose's Diagrams

- 1- 1c+2c ½ DblFig8 (to start, 1c cross down and 2c dance up, 2c finish facing out) ; 1c dance down NHJ between 3c and cast up to 2plx **while**{2} 2c cast up and stand (2x,1x,3)
- 9- 1c+3c ½ DblFig8 (1c cross down and 3c dance up) ; 1c dance up NHJ between 2c and cast off to 2pl own side (2x,1,3x)
- 17- 1c Petronella {8} (to 2x,1x,3x)
- 25- 2c+3c Petronella {8} **while**{2} 1c casts Rsh back | cross (M / W between 3c / 2c) ; cast to 2pl | set with 2c+3c (2,1,3)

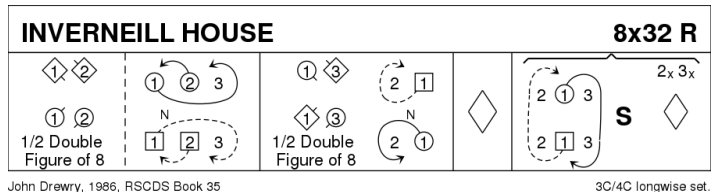

17 THE BEES OF MAGGIEKNOCKATER J32 · 4/4L

John Drewry: A Guide to Scottish Country Dancing · Crib: Eric Ferguson's SCD Cribbs · Diagram: Keith Rose's Diagrams

- 1- 1c cross RH | cast off (2c up) ; 1c+3c RHA, finish as pairs 1M+3W & 3M+1W facing out on W/M side in promhold
- 9- Pairs+ 2c+4c Rsh ½Reels3 on sides ; pairs meet & take P in promhold for Lsh ½Reels3 on sides
- 17- Meet and repeat (as pairs Rsh ½Reels3 ; with P Lsh ½Reels3)
- 25- 1c (passing inside) turn 3c 1½ Easy Hand ; 1c cross and passing inside turn 4c EH 1½ (to 2,3,4,1)

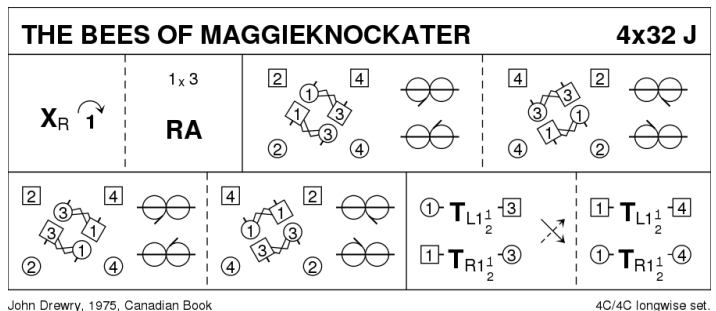

18 THE BYRON STRATHSPEY S32 · 3/3L

John Drewry: Deeside Book Part 2 · Crib: Eric Ferguson's SCD Cribbs · Diagram: Keith Rose's Diagrams

- 1- 1c+2c+3c Petronella Turn into midline, set ; all turn P 1¼ BH to (1,2,3)
- 9- 2c Teapots R (2M+3c & 2W+1c) ; and L, to (1,2,3) with 1c facing out and 2c facing up in promhold
- 17- 2c (promhold) +1W+1M Reel3 across (Rsh to 1W), at end all dance in for
- 25- 2c+1c+3c Allemande (to 3,1,2).

