

# 28th August Club Dance

St Chad's Parish Centre, Otley Road, Leeds at 7.30pm

## 1 LE PAPILLON J32 · 3/4L

*Thomas Skillern: Scottish Country Dances for Children · Crib: E-cribs · Diagram: Keith Rose's Diagrams*

- 1- 1c (long) cast off (2c up) ; 1c+3c Circle4 left
- 9- 1c cast to the top (2c down) ; 1c+2c Circle4 left
- 17- 1c lead down {3}, up {3} | cast into 2pl (2c up)
- 25- 2c+1c R&L (2,1,3)

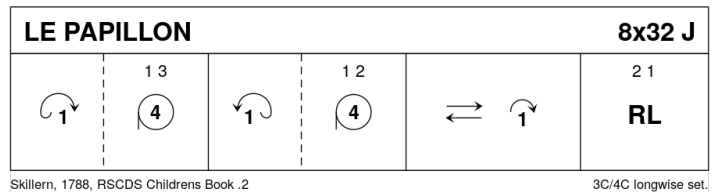

## 2 THE GEORDIES' DIAMOND REEL R32 · 3/4L

*Roy Goldring: 14 Social Dances for 2000 · Crib: E-cribs*

- 1- 1c cross down (no hands) and face out (2c up) | 1c+3c change places EH, 3c finish facing out & down and 1c facing in ; ½ Reels3 on the sides (1x,3,2)
- 9- Repeat [1-8] from new places (to 1,2,3), 1c facing in ; 2c out and up.
- 17- 1c followed by 2c down the middle ; 2c+1c set to P | 2c dance to 1pl facing out and down **while{2}** 1c dance to 2pl in the centre, -
- 25- 2W+1W+3W RHA **while{4}** 2M+1M+3M LHA ; 1c dance to the top and cast to 2pl. (2,1,3)

## 3 THE QUAKER'S DAUGHTER S32 · 3/3L

*Roy Goldring: A Reel for Alice and Other Social Dances · Crib: E-cribs · Diagram: Keith Rose's Diagrams*

- 1- 1c+2c set | 1c cast **while{2}** 2c cross up (no hands) ; 1c+3c set | ½ RHA (2x,3x,1x)
- 9- 2M+1W change places RH | 2W+1M change places RH ; 3c cross | all set advancing into
- 17- 1c+3c+2c Allemande
- 25- 2c+3c+1c Circle6 and back

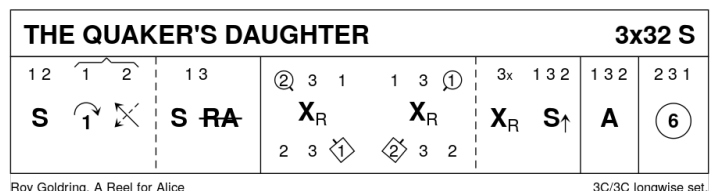

## 4 YAN, TAN, TETHERA J32 · 3/4L

Derek Haynes: Carnforth Collection of SC Dances 2 · Crib: E-cribs · Diagram: Keith Rose's Diagrams

- 1- 1c cross RH | cast (2c up) ; ½ Fig8 L (Rsh round 4cnr) to face 1cnrs
- 9- Corner chain: (turn 1cnr RH ½ | corners turn each other LH in the middle ; half RH turn brings 1c back to centre | turn LH 1¼ to 2cnrs)
- 17- Repeat with 2cnrs, finish 1c facing 1cnr
- 25- Lsh Reels3{6} on sides | cross RH to (2,1,3)

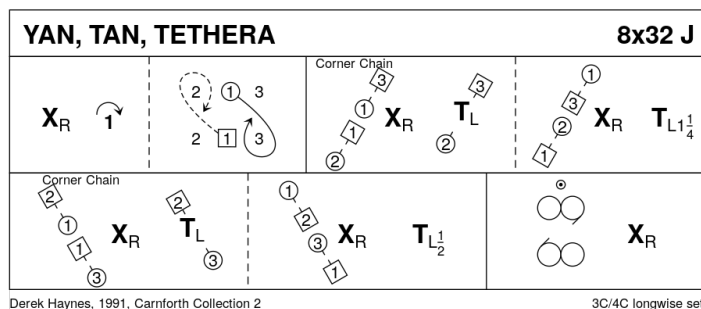

(The name means 1,2,3 in the local dialect of Yorkshire sheep farmers, in the area where Derek lives.)

## 5 TAMBOURINE R32 · 3/4L

Lawrie Bowlen: East Ivanhoe Book · Crib: E-cribs · Diagram: Keith Rose's Diagrams

- 1- 1c lead down the middle (2c up) and up to 2pl
- 9- ½Reels3 across, Lsh to 1cnrs ; ½Reels3 on sidelines (Rsh to 2cnr pos), cnrs end with loop
- 17- ½Reels3 across, Lsh to 3cnr pos ; ½Reels3 on sidelines (Rsh to 4cnr pos) (to 2,1,3) (1c and 2cnrs move cclw, 1cnrs move clw)
- 25- 2c+1c+3c circle6 and back

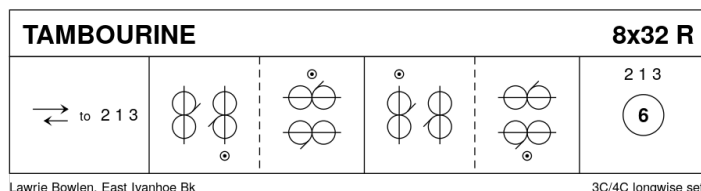

## 6 SANDS OF MORAR S32 · 3/4L

Barry Priddey: RSCDS XLV 6 · Crib: E-cribs · Diagram: Keith Rose's Diagrams

- 1- 1c Fig8 round 2c, giving hands
- 9- All Mirror Reels3 on own side, 1c starts in, join hands on meeting P
- 17- 1c turn BH | 1c dance to 3pl NHJ **while{4}** 2c+3c continue reel to top and follow behind 1c ; 3c+2c+1c set facing down | 1c cast to top, 2c+3c following to finish (1,2,3)
- 25- 1c+2c Tourbillon (1c+2c turn P BH ½, opening out to one place clw in the square (1c to W side, 2c to M side) | 1c set to 2c ; repeat figure (to 2x,1x) | 2c+1c cross RH (2,1,3)

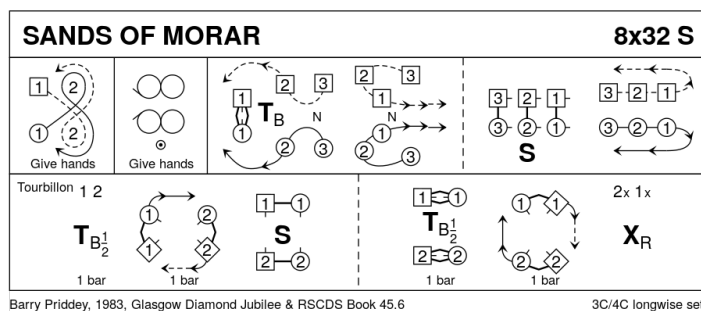

## 7 THE LAIRD OF MILTON'S DAUGHTER J32 · 3/4L

Craigmyle: RSCDS XXII 10 · Crib: E-cribs · Diagram: Keith Rose's Diagrams

- 1- 1c set, cross RH ; cast off (2c up), turn LH to 1cnrs
- 9- Corners' chain: 1c+1cnrs turn ½ RH | 1cnrs turn LH ; 1c+1cnrs turn back RH ½ | 1c turn LH 1¼ to 2cnrs
- 17- Repeat with 2cnrs, 1c crossing LH to 2pl
- 25- 2c+1c+3c circle6 and back

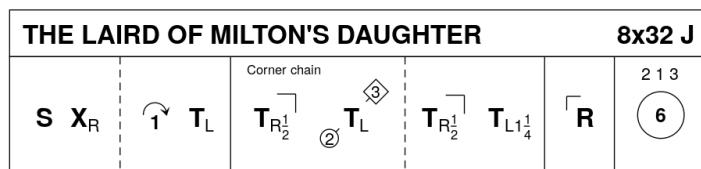

Lord Craigmyle, RSCDS Book 22.10

3C/4C longwise set.

## 8 THE FINAL REEL R32 · 3/4L

Ian Barbour · Crib: MiniCribs · Diagram: Keith Rose's Diagrams

- 1-8 1s cross RH, cast 1 place & turn LH 1.1/4 times to end 1M between 2s & 1L between 3s
- 9-16 2s+1s+3s Set+Link for 3 twice 1s end facing 1st corners pstns
- 17-24 1s dance 1/2 reel with 1st corners & 1/2 reel with 2nd corners, 1s ending in 2nd place own sides
- 25-32 2s+1s+3s circle 6H round & back

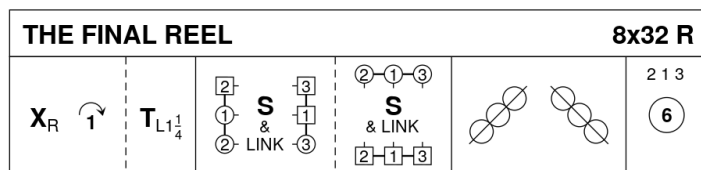

Ian Barbour

3C/4C longwise set

## 9 PROGRAMME ITEM – Interval

## 10 ALL THE EIGHTS J32 · 3/4L

Brenda Burnell: The Leeds Golden Collection · Crib: SCDDDB Contributed Cribs & Diagrams · Diagram: Keith Rose's Diagrams

- 1-6 Reel of three on the sides, 1s crossing
- 7-8 1s dance down to face 3m, promenade hold, 2c dance to 1st place
- 9-16 1s dance R Sh reel of three with 2nd corners
- 17-24 1s dance L Sh reel of three with 1st corners
- 24-32 1s cross down between 3s, cast up to 2nd place, dance up between 2s, cast to 2nd place own sides

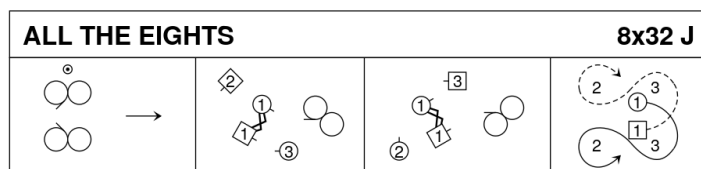

Brenda Burnell, 2008, Leeds Golden Collection

3C/4C longwise set.

## 11 THE HIGHLAND RAMBLER R40 · 3/4L

Roy Goldring: *Thirty Popular Dances, Volume Two* · Crib: *E-cribs* · Diagram: *Keith Rose's Diagrams*

- 1- 1c long cast to 2pl (2c up on [3-4] ; 1c+3c RHA (2,1,3)
- 9- 2c+1c LHA, 1W faces out ; 1W followed by 1M cast up round 2W and down the middle of set, 1W between 3c and 1M between 2c, all facing down
- 17- In lines of 3 down the middle (all swivel R) and up
- 25- 1M followed by 1W dance up, cast round 2W and into 2pl ; 1c turn RH
- 33- Circle6 and back

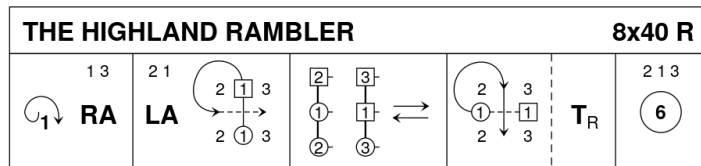

Roy Goldring, 1985, Leeds Silver Jubilee, RSCDS Thirty Popular Dances Vol 2

3C/4C longwise set.

## 12 THE SWAN AND THE TAY S32 · 3/3L

Audrey Saunders: *Scottish Country Dances for Perth 800* · Crib: *E-cribs* · Diagram: *Keith Rose's Diagrams*

- 1- 1c (in and down) Fig8 on own sides (give hands) (1,2,3)
- 9- 1c cross into Reels3{6} on opp. sides | 2c dance up as 1c face 1cnr
- 17- 1c+cnrs Pass&Turn, pass Rsh ; repeat with 2cnr, finish (2,1,3)
- 25- All set | cross RH ; chase ½ clw to (3,1,2)

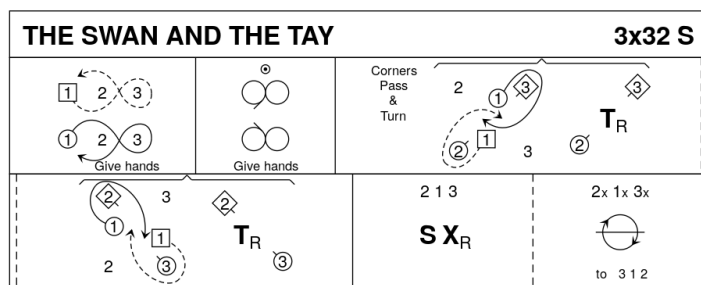

Audrey Saunders, Scottish Country Dances for Perth 800

3C/3C longwise set.

## 13 GRANVILLE MARKET J32 · 3/4L

Elinor M Vandegrift: *A Second Book of Graded Scottish Country Dances* · Crib: *E-cribs* · Diagram: *Keith Rose's Diagrams*

- 1- 1c+2c RHA, LHA
- 9- 1c cross RH | cast (2c up) ; ½ Fig8 up to face 1cnr
- 17- 1c turn 1cnr RH | pass Rsh ; turn 2cnr RH | pass Rsh to (2,1,3)
- 25- Circle6 and back

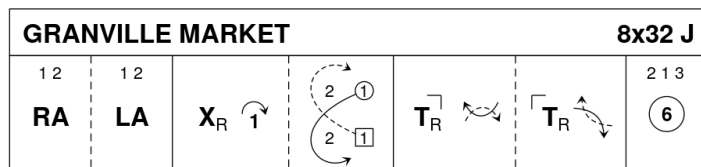

Elinor M Vandegrift, RSCDS Graded Book 2.18

3C/4C longwise set.

## 14 SCOTT MEIKLE R32 · 4/4L

Alice McLean: *RSCDS XLVI 3* · Crib: *E-cribs* · Diagram: *Keith Rose's Diagrams*

- 1- 1c cross RH | cast (2c up) ; ½ Fig8 up (2,1,3,4)
- 9- 1c+3c RHA, LHA (2,1,3,4)
- 17- Lsh opposing Reels3 across: (1W+3W behind dancing as one) with 2c and (3M+1M behind) with 4c (to 2,3,1,4)
- 25- 1c+4c ½ R&L ; turn RH 1½ (2,3,4,1)

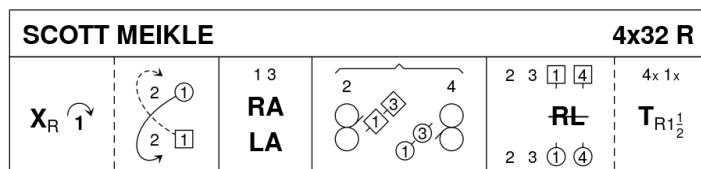

Alice McLean, Laurieston Collection 1, RSCDS Book 46.3

4C/4C longwise set.

## 15 THE SILVER CITY S32 · 3/4L

John Drewry: *Silver City Book of SCD · Crib: MiniCribs · Diagram: Keith Rose's Diagrams*

- 1-8 1s cross down to dance reflection reels of 3 on opposite sides
- 9-16 1s in prom hold dance reel of 3 across with 2s giving RSh to 2M, 2s dance into 1st place as 1s turn LH to face 1st corners
- 17-24 1s turn 1st corner RH, turn partner LH, turn 2nd corner RH, 1/2 turn partner LH to end 1L facing 2s & 1M facing 3s
- 25-32 1s dance RH across (Lady with 2s & Man with 3s), pass RSh & dance LH across with other couple

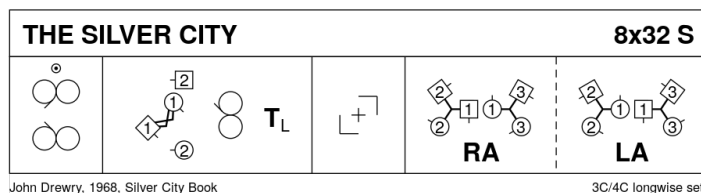

## 16 THE WILD GEESE J32 · 3/4L

RSCDS XXIV 3 · Crib: *E-cribs* · Diagram: Keith Rose's Diagrams

- 1- 1c+3c set advancing to midline with P on R | BiL ; 1c turn 3/4 RH and cast off to 3pl **while**{4} 3c turn 3/4 RH and lead to 1pl (3,2,1)
- 9- repeat [1-8] from new positions (1,2,3)
- 17- 1c lead down the middle (2c up on [19-20]) ; and up to (2,1,3)
- 25- 2c+1c R&L

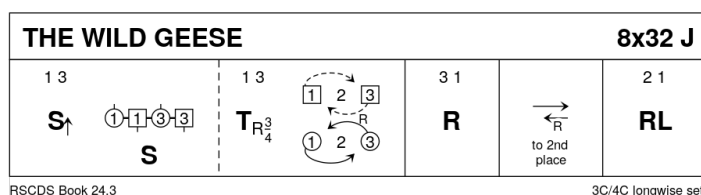

## 17 MAIRI'S WEDDING R40 · 3/4L

James B Cosh: *Twenty Two SCD · Crib: E-cribs* · Diagram: Keith Rose's Diagrams

- 1- 1c turn RH | cast (2c up) ; turn LH to face 1cnrs
- 9- 1c 1/2 Reel4 with 1cnrs (pass P Lsh) ; Repeat with 2cnrs
- 17- Repeat with 3cnrs (1cnr person) ; Repeat with 4cnrs (2cnr person)
- 25- 1W+2c & 1M+3c Reels3 across, Lsh to 1cnr
- 33- 2c+1c+3c circle6 and back

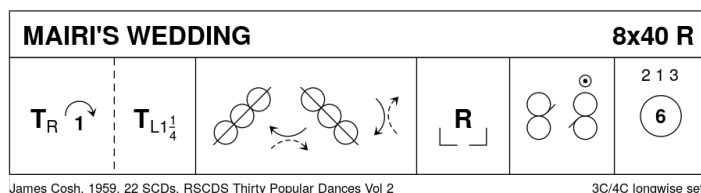

Note: Cosh explicitly tells 1c to pass Lsh in [9-24]; however the Rsh pass is quite common, and nicknamed »Mairi's Divorce«.