

Christmas Dance 15th December 2018

1 GRANVILLE MARKET J32 · 3/4L

Elinor M Vandegrift: A Second Book of Graded Scottish Country Dances · Crib: E-cribs · Diagram: Keith Rose's Diagrams

- 1- 1c+2c RHA, LHA
- 9- 1c cross RH | cast (2c up) ; ½ Fig8 up to face 1cnr
- 17- 1c turn 1cnr RH | pass Rsh ; turn 2cnr RH | pass Rsh to (2,1,3)
- 25- Circle6 and back

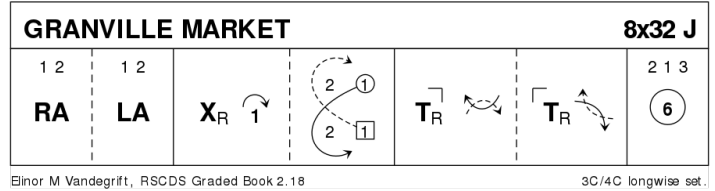

2 THE COUNTESS OF DUNMORE'S REEL R32 · 3/4L

Deirdre MacCuish Bark: RSCDS XLIX 12 · Crib: SCDDDB Contributed Cribs & Diagrams · Diagram: Keith Rose's Diagrams

- 1-- 1c set | dance down (2c up) ; cast up round 3c | set advancing to face 1cnr
- 9-- 1c turn 1cnrs RH, pass Rsh; turn 2cnrs RH, pass Rsh to face out in 2pl (cnrs dance for {4})
- 17-- [3C Chain Progression] 1c cast ¼ clw round set while{} 2c & 3c Turn RH ¾ | 2M+3W turn 1½ LH while{} the others promenade ½ clw round set | 3c+2c turn RH ¾ while{} 1c dance clw to 2pl
- 25-- all chase ½ way clw ; set - cross RH

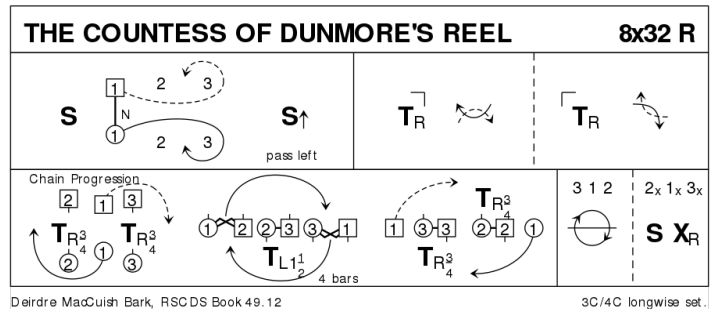

3C Chain Progression was earlier known as Chaperoned Chain Progression

3 MACDONALD OF THE ISLES S32 · 3/3L

Derek Haynes: Carnforth Collection of SC Dances 2 · Crib: E-cribs · Diagram: Keith Rose's Diagrams

- 1- 2c diagonal Reel4 with 1cnrs, at end dance Lsh round P to face 2cnrs
- 9- 2c diagonal Reel4 with 2cnrs (2cnr loop by the R) (to 1,2,3)
- 17- 1c+2c+3c »snowball« G-Chain (1c begin, 2 bars per hand) (to 3,2x,1)
- 25- 3c+2c ½ R&L ; 3c ½ Fig8 R (3M up, 3W down) (2,3,1)

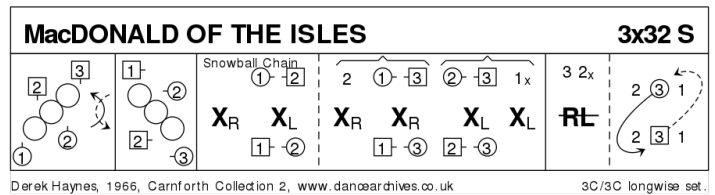

4 RODNEY'S RANT J32 · 3/4L

Ann Dix: QE Diamond Jubilee Dances · Crib: E-cribs · Diagram: Keith Rose's Diagrams

- 1-- 1c set | cast (2c up) ; dance between 3c and cast up (2,1,3)
- 9-- Diagonal R&L (3x,1,2x)
- 17-- All S&Link3 into lines across ; repeat (2,1x,3)
- 25-- 1c ½ Fig8 L (W up, M down) ; All turn P RH (2,1,3)

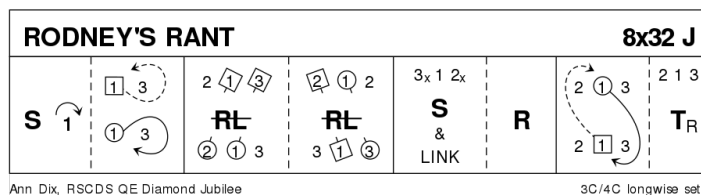

5 TRIP TO TIMBER RIDGE R32 · 3/4L

Linda Henderson: RSCDS LII 12 · Crib: E-cribs · Diagram: Keith Rose's Diagrams

- 1-- 1c turn RH | cast (2c up) ; 1W+2c & 1M+3c RHA, 1c facing 1cnrs at end
- 9-- Corners Pass and Turn, on [16] 1c pull Rsh back to finish BtoB in centre facing opposite side
- 17-- DTr, on [23-24] 1c Petronella turn to 2pl (2,1,3)
- 25-- Circle6 and back

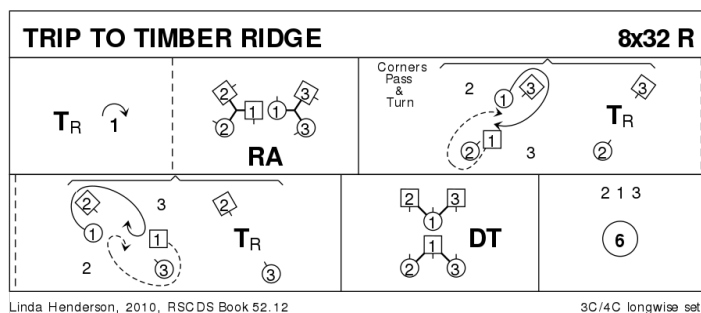

6 MISS ELEANOR S32 · 3/3L

Ann Dix: RSCDS XLIX 5 · Crib: SCDDDB Contributed Cribs & Diagrams · Diagram: Keith Rose's Diagrams

- 1-- Mirror Reels3 on the sides, 1c start in and down
- 9-- 1c set | cast off (2c up) ; turn RH to face out | cast R (2M down, 3W up)
- 17-- 3 couple Bourrel (3,1,2)
- 25-- Circle6 and back

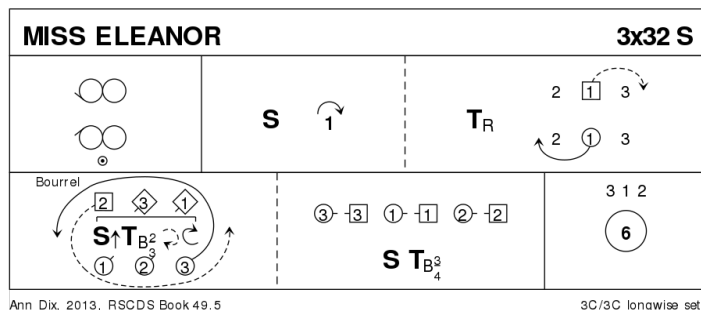

7 INCHMICKERY J32 · 5/5L

Roy Goldring: 14 Social Dances for 2000 · Crib: E-cribs · Diagram: Keith Rose's Diagrams

- 1-- 1c+2c circle4 L ; 1c long cast to 3pl (2c+3c up) (2,3,1,4,5)
- 9-- Teapots R ; and L (1c RHA with C on R ; LHA with C on L)
- 17-- 1M+5W & 1W+2M Turn RH to places ; 1M+2W & 1W+5M repeat LH
- 25-- 1c long cast to 5pl (4c+5c up) ; 5c+1c circle4 R (2,3,4,5,1)

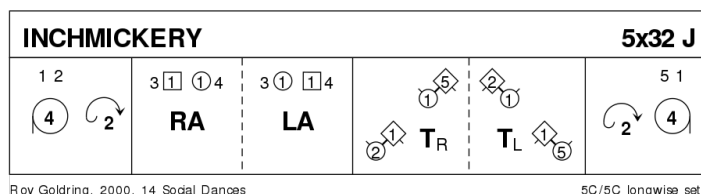

8 GLASTONBURY TOR R32 · 3/4L

Duncan Brown: RSCDS XLVII 11 · Crib: E-cribs · Diagram: Keith Rose's Diagrams

- 1- 1c+2c set | ½ RHA ; 1c+3c set | ½ LHA (2x,3x,1)
- 9- 1c set | cross RH ; cast up one (3c down) | turn LH to face 1cnr (pos)
- 17- ½ diag Reel4 with 1cnrs, pass Lsh ; ½ diag Reel4 with 2cnrs, 1c curve R into facing lines of 3 across, 1M at top, 1W at bottom
- 25- All S&Link3 ; 1c turn RH 1½ while{4} cnrs chase clw ½ round (2,1,3)

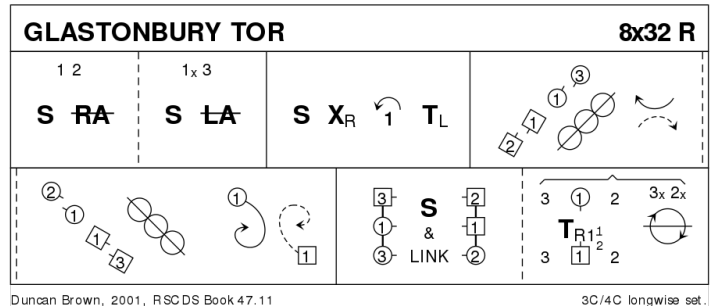

9 INTERVAL

10 SANDS OF MORAR S32 · 3/4L

Barry Priddey: RSCDS XLV 6 · Crib: E-cribs · Diagram: Keith Rose's Diagrams

- 1- 1c Fig8 round 2c, giving hands
- 9- All Mirror Reels3 on own side, 1c starts in, join hands on meeting P
- 17- 1c turn BH | 1c dance to 3pl NHJ while{4} 2c+3c continue reel to top and follow behind 1c ; 3c+2c+1c set facing down | 1c cast to top, 2c+3c following to finish (1,2,3)
- 25- 1c+2c Tourbillon (1c+2c turn P BH ½, opening out to one place clw in the square (1c to W side, 2c to M side) | 1c set to 2c ; repeat figure (to 2x,1x) | 2c+1c cross RH (2,1,3)

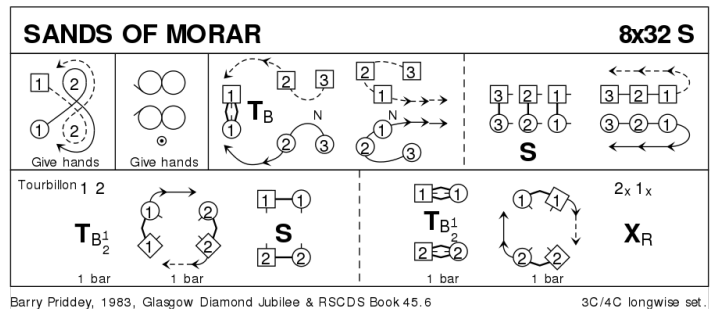

11 SCOTT MEIKLE R32 · 4/4L

Alice McLean: RSCDS XLVI 3 · Crib: E-cribs · Diagram: Keith Rose's Diagrams

- 1- 1c cross RH | cast (2c up) ; ½ Fig8 up (2,1,3,4)
- 9- 1c+3c RHA, LHA (2,1,3,4)
- 17- Lsh opposing Reels3 across: (1W+3W behind dancing as one) with 2c and (3M+1M behind) with 4c (to 2,3,1,4)
- 25- 1c+4c ½ R&L ; turn RH 1½ (2,3,4,1)

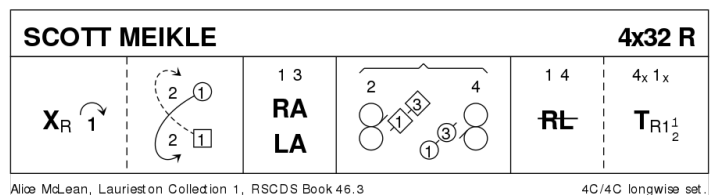

12 THE RAVEN'S DANCE J32 · 3/4L

Derek Haynes: Carnforth Collection of SC Dances 5 · Crib: E-cribs · Diagram: Keith Rose's Diagrams

- 1-- 1c+2c DbIFig8 (1c cross down, 2c dance up, no cast), at the end 2c face out
- 9-- Crossover Reels3 on the sides (1c cross down, 2c out and up), finish 1c side by side at top facing down, W on the R, 2c facing out
- 17-- 1c (together) +2c Lead-change Reel3 across, Rsh to 2M. 2c finish in 1pl with 1c in between facing down
- 25-- 1c dance down, cast up round 3c, lead up, cross between 2c and cast off (2,1,3)

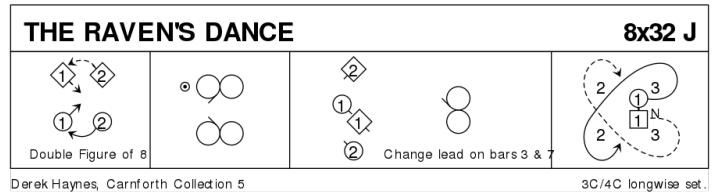

13 THE SILVER CITY S32 · 3/4L

John Drewry: Silver City Book of SCD · Crib: MiniCribs · Diagram: Keith Rose's Diagrams

- 1-8 1s cross down to dance reflection reels of 3 on opposite sides
- 9-16 1s in prom hold dance reel of 3 across with 2s giving RSh to 2M, 2s dance into 1st place as 1s turn LH to face 1st corners
- 17-24 1s turn 1st corner RH, turn partner LH, turn 2nd corner RH, 1/2 turn partner LH to end 1L facing 2s & 1M facing 3s
- 25-32 1s dance RH across (Lady with 2s & Man with 3s), pass RSh & dance LH across with other couple

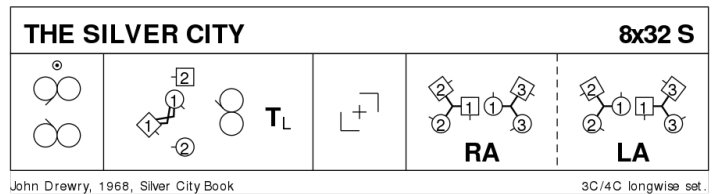

14 THE RUTLAND REEL R40 · 3/4L

Robert Senior: RSCDS XLVIII 2 · Crib: E-cribs · Diagram: Keith Rose's Diagrams

- 1-- 1c set | cast off (2c up) ; cross down RH and cast up to (2,1x,3)
- 9-- 2c+1c La-Chain
- 17-- Reels3{6} on the sides, 1c Rsh to 3c | 1c turn 3c RH 1/2 on sides (2,3,1x)
- 25-- 3c+1c M-Chain (2,3,1x)
- 33-- 1W followed by 1M cast up and cross to own side (3c down) ; 1c+3c Circle4 L (2,1,3)

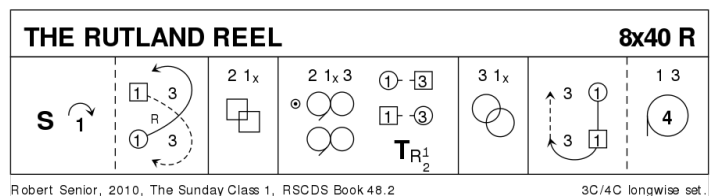

15 NEWARK CASTLE J48 · 4S

Pat Harland: *The Sunday Class Dance Book 2* · Crib: *E-cribs* · Diagram: *Keith Rose's Diagrams*

- 1-- 1c set | cross (no H) to centre ; 1W+2c LHA **while{4}** 1M+4c RHA
- 9-- 1c cross between 3c, cast out (W clw, M cclw) to original place | set to P
- 17-- All advance to centre | retire with cnr ; All S&Link
- 25-- All advance to centre | retire with next person ; All S&Link (4M+2W, 1M+3W, 2M+4W, 3M+1W)
- 33-- Cpls in 1pos & 3pos ½ R&L ; ½ La-Chain
- 41-- Cpls in 2pos & 4pos repeat [33-40]

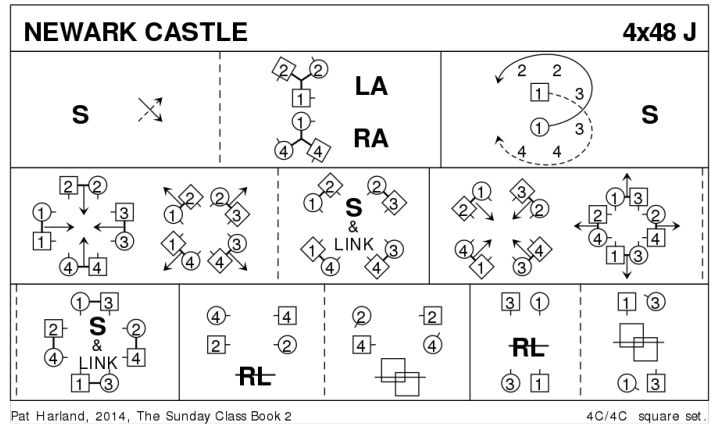

16 CITY OF BELFAST S32 · 3/3L

Lucy Mulholland: *RSCDS XLVIII 6* · Crib: *E-cribs* · Diagram: *Keith Rose's Diagrams*

- 1-- 1c ½ Fig8 round 2c ; 1c turn 2c EH 1¼ into line across, 1c in the middle
- 9-- 1c+2c Reel4, finish 2c in 1pl and 1c (last pass is Lsh) facing 1cnr
- 17-- 1c set to 1cnr | set to 2cnr, dancing R into sideline (2,1x,3) ; All set | 1c cross RH
- 25-- 1c+3c Espagnole (2,3,1)

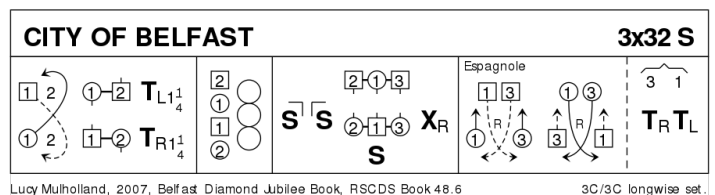

Espagnole: both W lead RHJ to M side, cross and cast back to exchanged places while Men cross to W side, lead RHJ back to M side crossing to exchanged places ; all turn P EH (2,1)

17 THE HIGHLAND RAMBLER R40 · 3/4L

Roy Goldring: *Silver Jubilee 25 - Leeds Branch* · Crib: *E-cribs* · Diagram: *Keith Rose's Diagrams*

- 1-- 1c long cast to 2pl (2c up on [3-4] ; 1c+3c RHA (2,1,3)
- 9-- 2c+1c LHA, 1W faces out ; 1W followed by 1M cast up round 2W and down the middle of set, 1W between 3c and 1M between 2c, all facing down
- 17-- In lines of 3 down the middle (all swivel R) and up
- 25-- 1M followed by 1W dance up, cast round 2W and into 2pl ; 1c turn RH
- 33-- Circle6 and back

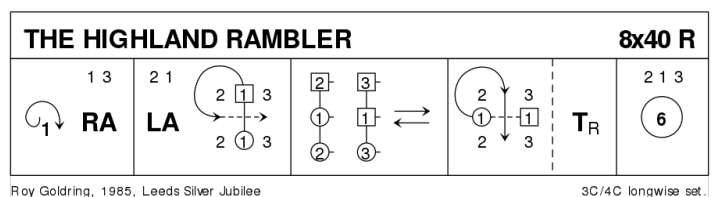

18 EXTRAS

19 EH3 7AF J32 · 3/4L

Roy Goldring: RSCDS XL 6 · Crib: E-cribs · Diagram: Keith Rose's Diagrams

- 1- 1c lead down the middle and up, on [8]
2c+3c step in for
- 9- 1c+2c+3c Promenade, at end 1c cast
off (to 2,1,3)
- 17- 1c cross Rsh | turn 1c nr RH ; cross
up/dn Rsh | turn 2c nr RH (2,1x,3) |
- 25- 2c+1M & 1W+3c RHA ; 1c ½Fig 8 Rsh round 4c nr (2,1,3)

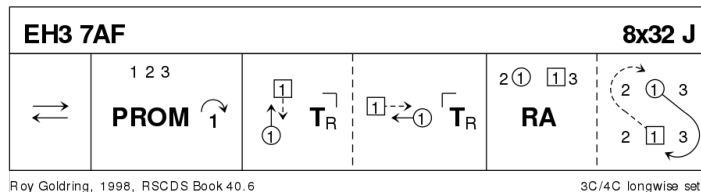

20 INVERNEILL HOUSE R32 · 3/4L

John Drewry: RSCDS XXXV 2 · Crib: E-cribs · Diagram: Keith Rose's Diagrams

- 1- 1c+2c ½ DbIFig8 (to start, 1c cross
down and 2c dance up, 2c finish facing
out) ; 1c dance down NHJ between 3c
and cast up to 2plx **while**{ 2c cast up
and stand (2x,1x,3)
- 9- 1c+3c ½ DbIFig8 (1c cross down and
3c dance up) ; 1c dance up NHJ between 2c
and cast off to 2pl own side (2x,1,3x)
- 17- 1c Petronella {8} (to 2x,1x,3x)
- 25- 2c+3c Petronella {8} **while**{ 1c casts Rsh
back | cross (M / W between 3c /2c) ; cast to 2pl | set
with 2c+3c (2,1,3)

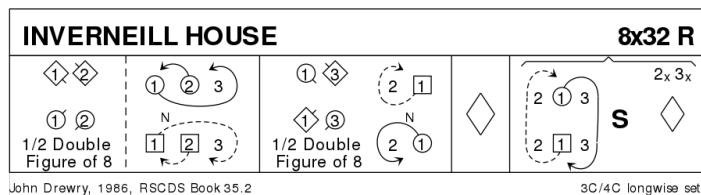

21 CHERRYBANK GARDENS S32 · 3/3L

John Drewry: Bankhead Book Part 1 · Crib: E-cribs · Diagram: Keith Rose's Diagrams

- 1- 1c+2c set | petronella in tandem ;
repeat (2x,1x,3)
- 9- 2c+1c set | 2c cross RH **while**{2} 1c
cross LH ; 1W+2c & 1M+3c RHA
(Teapots) to sidelines (2,1,3)
- 17- 1c+3c S&Link ; 3c+1c circle4 left, end
3c facing 1c for
- 25- G-Chain (2c cross to start) (2, 3, 1)

