

Leeds Scottish Country Dance Club 24th March 2018

Music: Neil Barron, MC: Veronica Hughes

St Chad's Parish Centre, LS16 5JT, 7.30pm – 10.45pm

1 PELORUS JACK J32 · 3/4L

Barry Skelton: RSCDS XLI 1 · Crib: Eric's E-cribs · Diagram: Keith Rose's Diagrams

- 1– 1c cross RH, cast (2c up) ; 1c+3c RHA, finish 1M facing 1cnr, 1W behind him
- 9– 1c in tandem +1cnrs ½ diagonal Reel3, Rsh to 3W (1M & 1W loop R singly for lead change, so 1W now leads P) ; ½ diagonal Reel3, Rsh to 2W (+ lead change)
- 17– Continue pattern twice
- 25– 2c+1c LHA ; 1c turn LH ½ | all set (2,1,3)

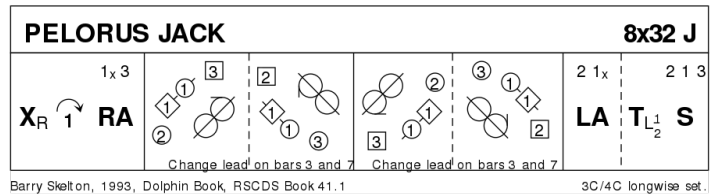

2 SCOTT MEIKLE R32 · 4/4L

Alice McLean: RSCDS XLVI 3 · Crib: Eric's E-cribs · Diagram: Keith Rose's Diagrams

- 1– 1c cross RH | cast (2c up) ; ½ Fig8 up (2,1,3,4)
- 9– 1c+3c RHA, LHA (2,1,3,4)
- 17– Lsh opposing Reels3 across: (1W+3W behind dancing as one) with 2c and (3M+1M behind) with 4c (to 2,3,1,4)
- 25– 1c+4c ½ R&L ; turn RH 1½ (2,3,4,1)

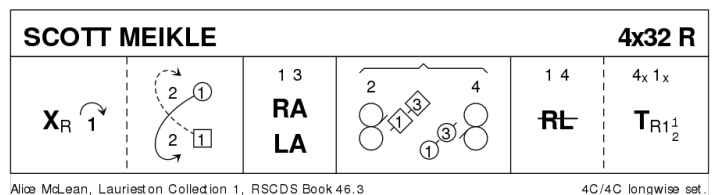

3 ALISON ROSE S32 · 4/4L

Derek Ivory: Imperial Book of Scottish Country Dances - Volumes 1-3 · Crib: Eric's E-cribs · Diagram: Keith Rose's Diagrams

- 1– 1c lead down the middle and loop up into 4pl (2c+3c+4c up) ; all set | Circle8 L for two places
- 9– all M (at top) LHA while{4} all W (below) RHA ; Continue both HA, but as each couple meets (order 1,4,3,2) they cross to the other wheel (W pass in front)
- 17– As couples meet again the W join RH with P, the M dancing as if still in RHA, and (1c leading) unwind and lead up the middle and out to opposite sidelines {6} | all turn P RH ½ into
- 25– 1c+4c+3c+2c Allemande (to 2,3,4,1)

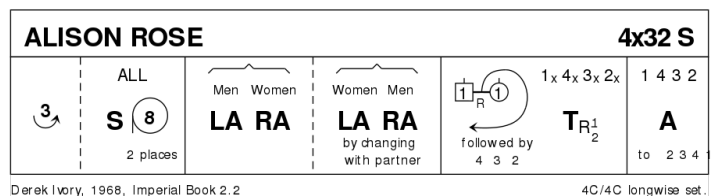

»Easier version« for [17-20]: As couples meet the W join NH with P who maintain RHA (continue as described)

4 THE MILLER OF SESSNIE J32 · 5/5L

Roy Goldring: 15 Social Dances · Crib: Eric's E-cribs · Diagram: Keith Rose's Diagrams

- 1- 1c with 2c+3c+4c following dance down between 5c and cast up to places
- 9- 1c (start inwards) Fig8 on own side round 2c & 3c **while**{8} 5c (start outwards, no cast) Fig 8 on own side round 4c & 3c (to 1,2,3,4,5)
- 17- 1c+2c RHA ; 1c cross down as 2c cast up | 1c+3c change places easy hand (2,3,1x,4,5)
- 25- 1c+4c LHA ; 1c cross down as 4c cast up | 1c+5c change places easy hand (2,3,4,5,1)

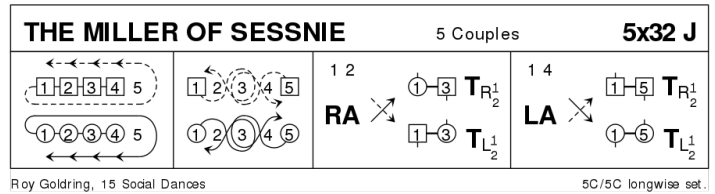

5 THE PIPER AND THE PENGUIN R88 · 4S

Roy Goldring: The Scotia Suite of Scottish Country Dances · Crib: Eric's E-cribs · Diagram: Keith Rose's Diagrams

- 1-16 All W dance Rsh round cnr ; RHA in middle ; Lsh round P ; LHA in middle, to places
- 17-32 All M dance Rsh round P ; RHA in middle ; Lsh round cnr ; LHA in middle, to places
- 33-48 1c+3c turn RH 1¼ ; 1M & 3M (W following) dance between couple on the R and cast clw to places ; 1c+3c R&L
- 49-64 2c+4c repeat
- 65- All W dance into middle, swivel R and dance through own place clw half way round set
- 73- All M dance into middle, swivel L and dance through own place cclw half way round set
- 81- All turn P RH 1¼ ; promenade cclw half way round set, to own places

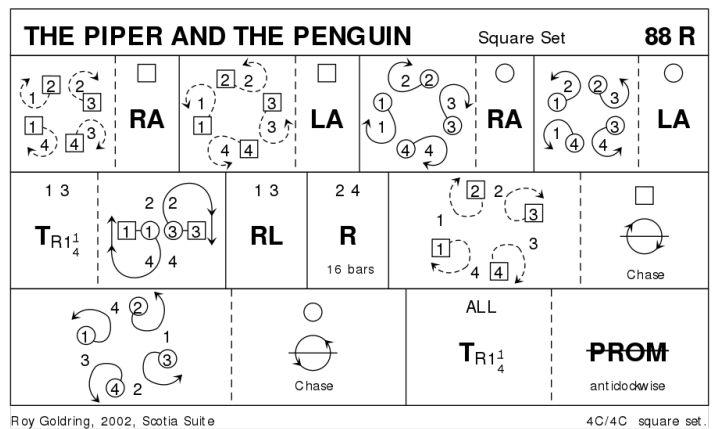

6 GANG THE SAME GATE S32 · 3/4L

Milton Levy: RSCDS XXXVI 4 · Crib: Eric's E-cribs · Diagram: Keith Rose's Diagrams

- 1- 1c cross RH | cast off 2 (2c+3c up) ; 1c cross RH and cast up (3c down) to (2,1,3)
- 9- 1c set passing Lsh | turn 1cnrs BH ; ½Reel4 with 2cnrs, at end 1c curve R to between end cpl (M above facing W below)
- 17- 1c set passing Lsh, turn 4cnr (2cnr persons) BH ; ½Reel4 with 1cnrs, at end curve R to (3x,1x,2x)
- 25- All S&Link3 ; repeat (2,1,3)

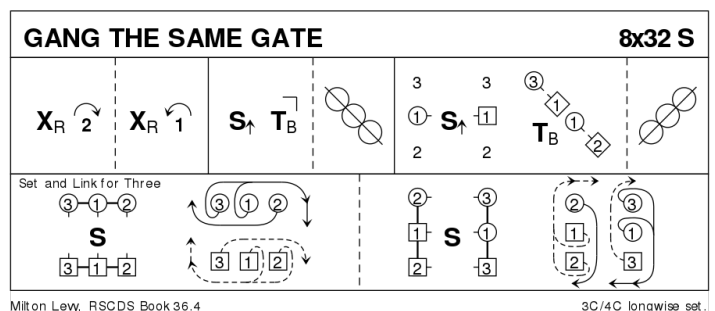

7 THE FIRST RAIN OF SPRING J32 · 3/3L

Wouter Joubert: RSCDS XLIX 4 · Crib: SCDDDB Contributed Cribes & Diagrams · Diagram: Keith Rose's Diagrams

- 1-- 1c dance down below 3c | cast up 1 place ; dance up to 1pl facing out | 1c+2c ½ turn EH, 2c face out
- 9-- 2c+1c DblFig8, 1c crossing up
- 17-20 1c+3c turn P RH ¾ and face P up/dn | set ;
- 21-28 (½ Celtic Reel) 1c+3c pass Rsh | "outers" chase ¼ way clw **while{2}** "inners" turn (no hands) ¾ Lsh to face same person ; repeat
- 29-32 1c+3c Turn P RH ¾ | all set

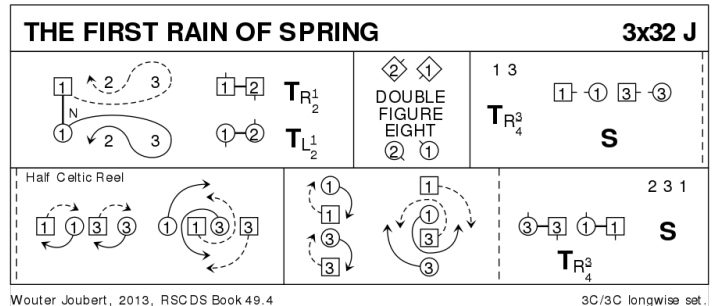

8 THE REEL OF THE ROYAL SCOTS R32 · 3/4L

Roy Goldring: The Leaflet Dances with Music · Crib: Eric's E-cribs · Diagram: Keith Rose's Diagrams

- 1-- 1W+2W (1M+2M) turn LH (RH) ½, finishing 1c BtoB in 2pl | All set as in DTr ; 1W+3W (1M+3M) turn RH (LH) ½ | 2c+3c+1c set as in DTr
- 9-- 1c followed by 3c dance up between 2c, cast off ; dance NHJ down through 3pl, cast up to face 1cnrs, 3c looping into 3pl
- 17-- 1c turn 1cnrs RH, pass Rsh (cnrs dance for {4}) ; turn 2cnrs RH (same), and cross Rsh to (2,1,3)
- 25-- All circle6 and back

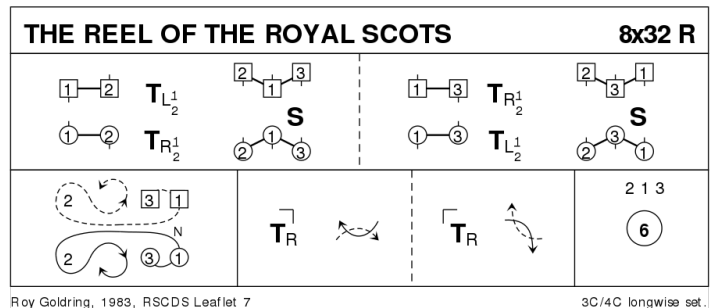

9 PROGRAMME ITEM – INTERVAL

10 MAJOR IAN STEWART J32 · 3/4L

John Drewry: RSCDS XXXV 4 · Crib: Eric's E-cribs · Diagram: Keith Rose's Diagrams

- 1-- 1c+2c turn RH ½ into | ½ RHA into ; 2c+1c turn RH, 2c finish facing out (2,1,3)
- 9-- Opposing Reels3 on own sides (1c inwards, Rsh to 4cnr) 1c finish facing 1cnr, 2c+3c finish with loops
- 17-- SetH&G to (2,1,3)
- 25-- Circle6 L {3}, cross R foot over L and chase back cclw to (2,1,3)

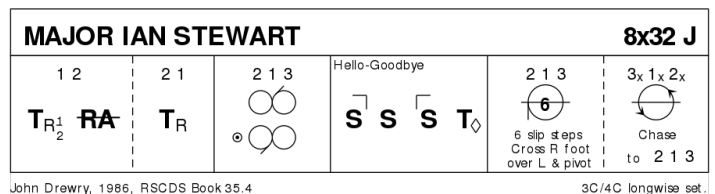

11 MISS JOHNSTONE OF ARDROSSAN

R32 · 5/5L

Roy Goldring: 14 Social Dances for 2000 · Crib: Eric's E-cribs · Diagram: Keith Rose's Diagrams

- 1- 1c set | cast off (2c up) ; 1c followed by 3c dance up and cast round 2c to (2,3,1,4,5)
- 9- 1c+4c+5c mirror Reels3, 1c cross down to enter, 4c start out and up (2,3,1x,4,5)
- 17- 2c+3c+1c mirror Reels3, 1c cross up to enter, 3c start out and down
- 25- 1c set | cast off to 4pl (4c up) ; 1c followed by 5c dance up and cast round 4c to (2,3,4,5,1)

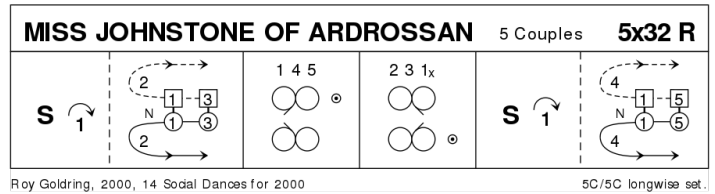

12 THE DREAM CATCHER

S96 · 4S

Eileen Orr: RSCDS XLV 9 · Crib: Eric's E-cribs · Diagram: Keith Rose's Diagrams

Part 1

- 1- All Circle8 and back
- 9- The Swirl: 1c+3c turn RH into Allemande hold facing in | dance Lsh round other C half way ; 1c+3c LHA, on [16] let go and swivel L to face side couples, BtoB with P, 1c below 3c
- 17- Parallel Rsh Reels4 across, finish as at start
- 25- All set | 1M+3W & 3M+1W NHJ dance out between side couple, cross and cast to own places, change place with P RH

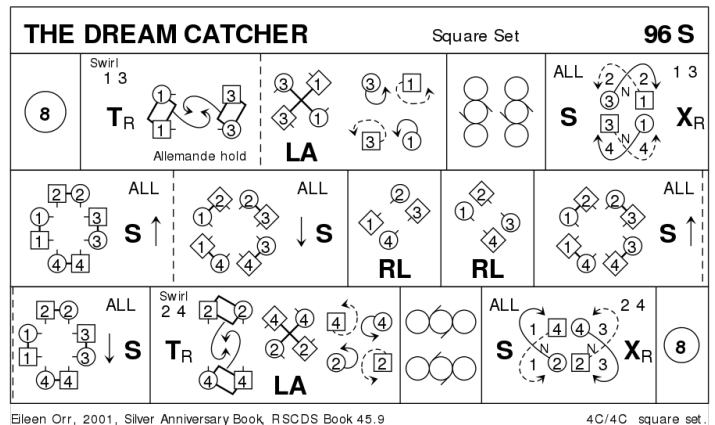

Part 2

- 1- All set | advance to middle and form circle ; retire with cnr | set
- 9- 1W+4M & 3W+2M R&L, starting across the set
- 17- 1M+2W & 3M+4W R&L, starting across the set
- 25- All set | advance to middle and form circle ; retire with P | set

Part 3

- 1-24 2c+4c starting, repeat part 1, 9-32 in the other orientation (The Swirl, Reels4 up/dn, return to places)
- 25- All Circle8 and back

13 THE WEATHERCOCK J32 · 4/4L

Veronica Hughes: *A Second Book of Graded Scottish Country Dances* · Crib: *Eric's E-cribs* · Diagram: *Keith Rose's Diagrams*

- 1– Parallel Reels4 on the sides
- 9– 1c+3c set advancing to midline and join RH with P, LH in middle | BiL (2c+4c up) ; 1c+2c & 3c+4c RHA
- 17– 1W+3M turn LH $\frac{3}{4}$ while } 1M+3W dance round clw $\frac{1}{4}$ to meet P in line across | BiL ; repeat
- 25– 3c+2c & 1c+4c RHA ; 1c+3c turn person ahead (»corner«) RH to finish (2,3,4,1) (M turn once and a bit, W turn $1\frac{1}{2}$ and a bit)

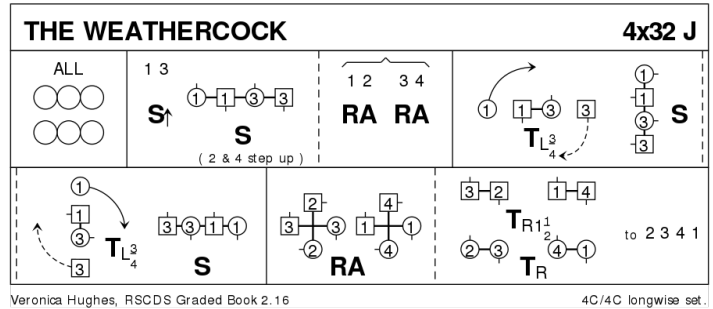

note: the set tends to move upwards; ease down gently in the turns to end in the right positions

14 SLEEPY MAGGIE R32 · 3/4L

Alexander Bowman: *RSCDS XI 5* · Crib: *Eric's E-cribs* · Diagram: *Keith Rose's Diagrams*

- 1– 1c+2c circle4 to the left ; 1c set | cast off (2c up)
- 9– 1c+3c RHA ; LHA, 1c finish facing 1cnrs
- 17– 1c set to and turn corners, finish facing 1cnrs
- 25– Reels3{6} with cnrs (Lsh to 1cns), 1c cross RH (2,1,3).

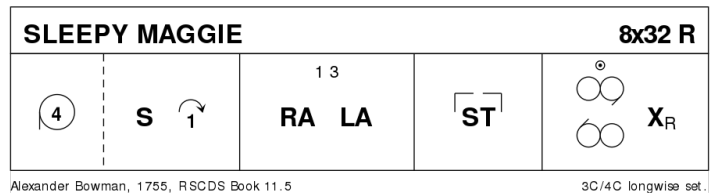

15 THE MINISTER ON THE LOCH S32 · 3/3L

Roy Goldring: *Magazine Dances 2005-2009* · Crib: *Eric's E-cribs* · Diagram: *Keith Rose's Diagrams*

- 1– 1c+2c Pousette
- 9– 1c dance down 2 places, turn BH ; dance up 2 places, turn BH, open upwards and face out
- 17– 1c+3c DbIFig8 round 2c, 1c casting, 3c crossing up to begin, 1c finish facing out for
- 25– 1W+2W & 1M+2M turn EH $1\frac{1}{2}$; 1c+3c repeat (2,3,1)

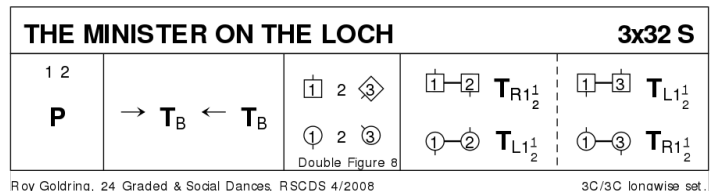

16 THE BEES OF MAGGIEKNOCKATER

J32 · 4/4L

John Drewry: *The Canadian Book of Scottish Country Dances* · Crib: *Eric's E-cribs* · Diagram: *Keith Rose's Diagrams*

- 1– 1c cross RH | cast off (2c up) ; 1c+3c RHA, finish as pairs 1M+3W & 3M+1W facing out on W/M side in promhold
- 9– Pairs+ 2c+4c Rsh ½Reels3 on sides ; pairs meet & take P in promhold for Lsh ½Reels3 on sides
- 17– Meet and repeat (as pairs Rsh ½Reels3 ; with P Lsh ½Reels3)
- 25– 1c (passing inside) turn 3c 1½ Easy Hand ; 1c cross and passing inside turn 4c EH 1½ (to 2,3,4,1)

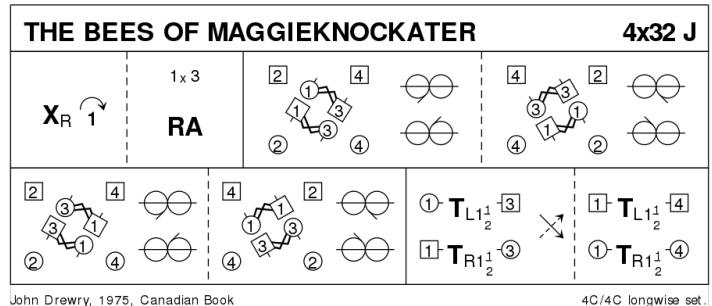

17 THE IRISH ROVER

R32 · 3/4L

James B Cosh: *Twenty Two SCD* · Crib: *Eric's E-cribs* · Diagram: *Keith Rose's Diagrams*

- 1– 1c lead through 3c (2c up) and cast up ; 1M+3c and 1W+2c RHA, finish facing 1cnrs.
- 9– 1c+1cnrs ½Reel4, pass Lsh ; ½Reel4 with 2cnrs, fast ¾ LH turn in the centre
- 17– 1W+3c (at top) & 1M+2c Reels3 across (Lsh to 1cnr pos), (to 3x,1,2x)
- 25– diagonal R&L (1M down,1W up) (2,1,3)

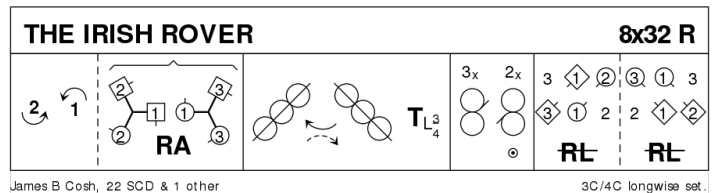

18 PROGRAMME ITEM – EXTRAS

19 THE DEIL AMANG THE TAILORS

R32 · 3/4L

RSCDS XIV 7 · Crib: *Eric's E-cribs* · Diagram: *Keith Rose's Diagrams*

- 1– 1c+2c set, ½ RHA ; set, ½ LHA
- 9– 1c lead down the middle and up, 2c step in for
- 17– 1c+2c Allemande
- 25– 2c+1c+3c circle6 and back.

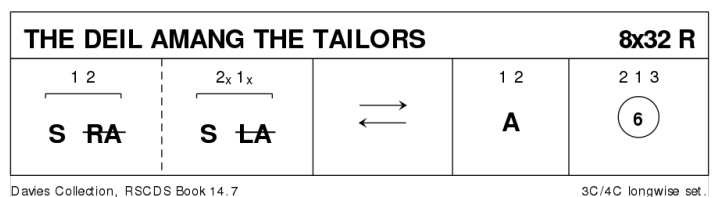

20 FISHERMAN'S REEL R32 · 5S

Petyt, Sue / Gamon, Jane: *Dunblane Holiday* · Crib: *Eric's E-cribs* · Diagram: *Keith Rose's Diagrams*

Square set plus 5M / 5W in middle face P with backs to 4c / 2c

- 1- 1c+2c+3c+4c circle8 and back **while** {8} 5c turn RH ; turn LH 1½
- 9- 5M+2c & 5W+4c RHA ; 5M+1c & 5W+3c LHA
- 17- 1c+5M+2c & 3c+5W+4c (couples in promhold) Reels3 Rsh to side couple, 5c meets (5M swivels L) and takes promhold facing 1c
- 25- (all C promhold) 5c+1c change places Rsh | 1c+4c repeat ; 4c+3c repeat | 3c+2c repeat, 2c is the new centre couple.

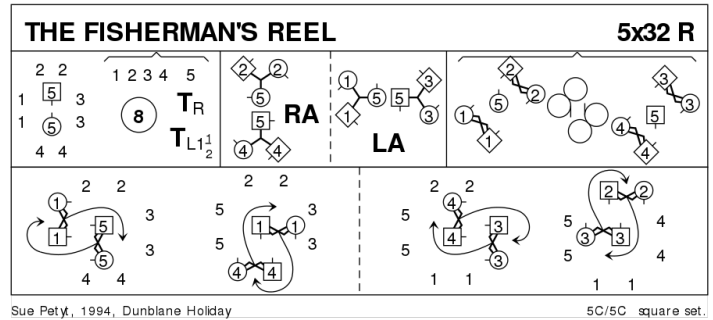

21 POSTIE'S JIG J32 · 4/4L

Roy Clowes: *Ormskirk Scottish Dances - Memorial Edition* · Crib: *Eric's E-cribs* · Diagram: *Keith Rose's Diagrams*

- 1- 1c+4c set, cast to middle positions (2c+3c step to end) ; 1c&4c ½ Fig8 round end C (2,1x,4x,3)
- 9- 1M+4M and 1W+4W cross NHJ, (W under men's arch), turn cnr ¾ with 'free' hand ; 1c facing 4c change places NHJ (arch going up), turn cnr as before
- 17- Repeat (Men's arch ; arch going up)
- 25- 1c+4c ½ R&L ; turn P RH

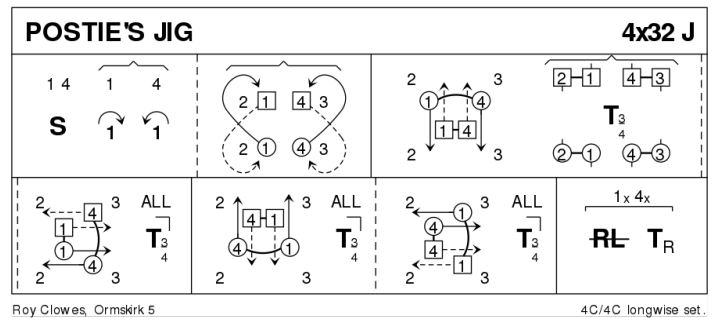

Note that both times the couple moving UP makes the arch.

22 CHERRYBANK GARDENS S32 · 3/3L

John Drewry: *Bankhead Book Part 1* · Crib: *Eric's E-cribs* · Diagram: *Keith Rose's Diagrams*

- 1- 1c+2c set | petronella in tandem ; repeat (2x,1x,3)
- 9- 2c+1c set | 2c cross RH **while**{2} 1c cross LH ; 1W+2c & 1M+3c RHA (Teapots) to sidelines (2,1,3)
- 17- 1c+3c S&Link ; 3c+1c circle4 left, end 3c facing 1c for
- 25- G-Chain (2c cross to start) (2, 3, 1)

