

Leeds Scottish Country Dance Club 26th May 2018

Music: Ian Slater, MC: Malcolm Brown

St Chad's Parish Centre, LS16 5JT, 7.30pm – 10.45pm

1 THE HAPPY MEETING J32 · 2/4L

RSCDS XXIX 9 · Crib: E-cribs · Diagram: Keith Rose's Diagrams

- 1– 1M+2W cross and dance $\frac{3}{4}$ Lsh round P, pass down/up Rsh, cast R round standing M/W to places
- 9– 1W+2M repeat (other shoulders)
- 17– 1c slip down the middle | set (1M starts L foot) ; slip to top | cast off (2c up)
- 25– 2c+1c A&R (all clap) ; turn P RH

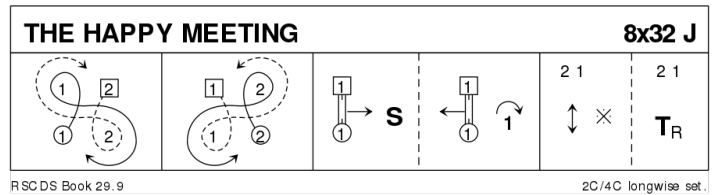

2 RODNEY'S RANT J32 · 3/4L

Ann Dix: QE Diamond Jubilee Dances · Crib: E-cribs · Diagram: Keith Rose's Diagrams

- 1– 1c set | cast (2c up) ; dance between 3c and cast up (2,1,3)
- 9– Diagonal R&L (3x,1,2x)
- 17– All S&Link3 into lines across ; repeat (2,1x,3)
- 25– 1c $\frac{1}{2}$ Fig8 L (W up, M down) ; All turn P RH (2,1,3)

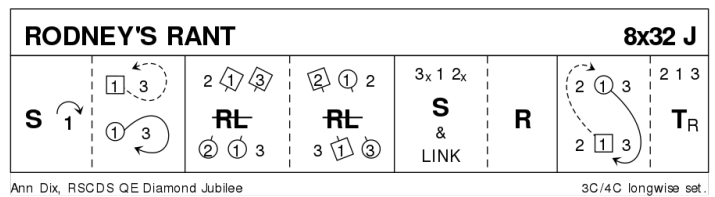

3 ARGYLL STRATHSPEY S32 · 3/4L

Roy Goldring: RSCDS XXXV 3 · Crib: E-cribs · Diagram: Keith Rose's Diagrams

- 1– 1c+2c+3c $\frac{1}{2}$ RH turn and remain in middle, swivel R and dance out to opposite side ; repeat, to own places
- 9– 1c+2c+3c Circle6 and back, 1c & 3c finish facing down / up the middle
- 17– 1c+3c R&L up / down, to own places
- 25– 1c+2c Tournée.

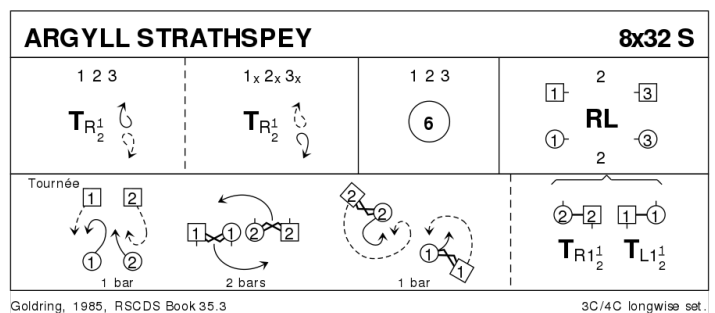

4 MIDNIGHT OIL J48 · 5/5L

John Drewry: Bankhead Book Part 3 · Crib: E-cribs · Diagram: Keith Rose's Diagrams

- 1-- 1c+3c lead far down (2c+4c up) | turn $\frac{3}{4}$ RH and face P, RHJ ; set , W turning under M's arm | 1c+3c dance up (W leading)
- 9-- 1c+2W & 3c+4W RHA ; 1c+4M & 3c+5M LHA, 1c+3c finish facing 1cnrs
- 17-- 1c+3c with 1cnrs pass and turn, pass P Rsh ; repeat with 2cnrs, at end pass P Rsh onto midline, W above and facing M
- 25-- Reel4 on midline, at end pass Rsh in the middle to finish 1c facing out in 2pl on W side / likewise 3c in 4pl on M side
- 33-- 1c dance out between 2W & 4W, split, cast round them, meet in middle, repeat through M side **while{8}** 3c do the same, starting between 4M & 5M. (1M & 3W pass Lsh between 4c). All finish where they started the reel, but 1M faces 3W
- 41-- 1W+3M set twice facing up and down **while{4}** 1M+3W turn RH to face P ; 1c+3c turn P LH $\frac{3}{4}$ | cast off on own side (4c+5c up) (2,4,1,5,3)

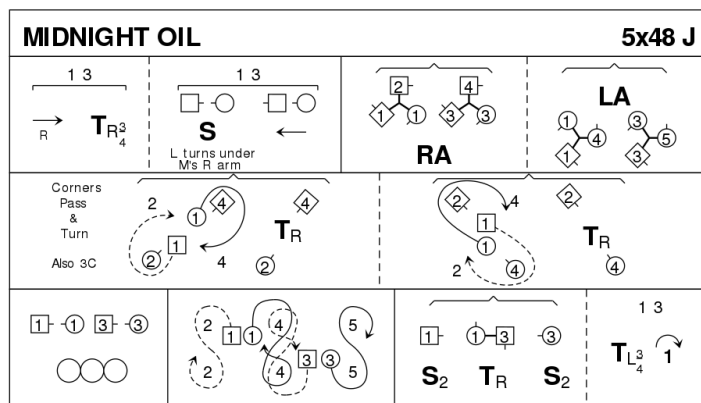

John Drewry, 1992, Bankhead Book 3

5C/5C longwise set.

5 THE COUNTESS OF DUNMORE'S REEL R32 · 3/4L

Deirdre MacCuish Bark: RSCDS XLIX 12 · Crib: SCDDDB Contributed Cribs & Diagrams · Diagram: Keith Rose's Diagrams

- 1-- 1c set | dance down (2c up) ; cast up round 3c | set advancing to face 1cnr
- 9-- 1c turn 1cnrs RH, pass Rsh; turn 2cnrs RH, pass Rsh to face out in 2pl (cnrs dance for {4})
- 17-- [3C Chain Progression] 1c cast $\frac{1}{4}$ clw round set while{} 2c & 3c Turn RH $\frac{3}{4}$ | 2M+3W turn $1\frac{1}{2}$ LH while{} the others promenade $\frac{1}{2}$ clw round set | 3c+2c turn RH $\frac{3}{4}$ while{} 1c dance clw to 2pl
- 25-- all chase $\frac{1}{2}$ way clw ; set - cross RH

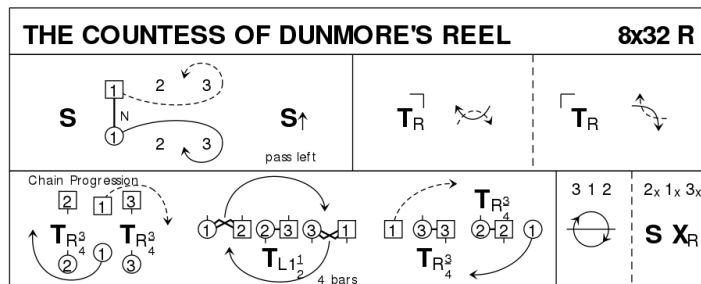

Deirdre MacCuish Bark, RSCDS Book 49. 12

3C/4C longwise set.

3C Chain Progression was earlier known as Chaperoned Chain Progression

6 THE FRIDAY CLASS S32 · 3/3L

Helen C.N. Brown: Forty and Counting

7 EQUILIBRIUM J32 · 3/4L

Ian Barbour: Set and Cast Off Volume 2 · Crib: E-cribs · Diagram: Keith Rose's Diagrams

- 1- 1c cast off (2c up), cross LH ; dance Lsh round 2cnrs to face 1cnrs (2,1x,3)
- 9- Rsh Reels3 in sideline (2,1x,3)
- 17-28 »Fig8 G-Chain«: 2M+1W (side) & 2W+3M (2nd diag) & 1M+3W (side) change places RH | 3M+3W (side) & 1W+1M (1st diag) & 2M+2W (side) change LH ; repeat figure twice ;; (all dance a Fig8, men dancing down the sidelines, women up).
- 29-32 1c set and cross over RH, on first turn finish facing out (2,1,3).

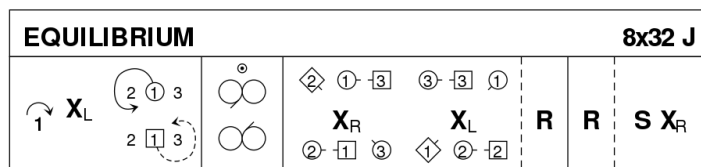

Ian Barbour, SDA, Set and Cast Off 2

3C/4C longwise set.

8 JOHN OF BON ACCORD R32 · 3/4L

Roy Goldring: RSCDS XXXIII 5 · Crib: E-cribs · Diagram: Keith Rose's Diagrams

- 1-16 4 progressive ½Reels3 across, as follows: 1c+2W (1c start Rsh) ; 1c+2M (start Lsh) ; 1c+3W (Rsh) ; 1c+3M (Lsh), 1c finish in 3pl a bit in from the sidelines (2c & 3c finish their reels in 1plx and 2plx)
- 17- 1c turn RH, cast up one place on own sides (3c down) ; 1c ½ Fig8 round 2c (2x,1x,3x)
- 25- All turn P ¾ RH to face P along the midline | All Set retaining RHJ ; all turn P ¾ RH (to 2,1,3) | All Set.

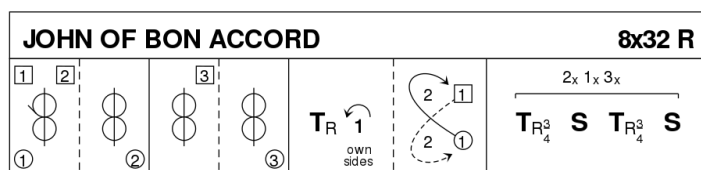

Roy Goldring, RSCDS Book 33.5

3C/4C longwise set.

9 PROGRAMME ITEM – INTERVAL

10 THE LAIRD OF MILTON'S DAUGHTER J32 · 3/4L

Craigmyle: RSCDS XXII 10 · Crib: E-cribs · Diagram: Keith Rose's Diagrams

- 1- 1c set, cross RH ; cast off (2c up), turn LH to 1cnrs
- 9- Corners' chain: 1c+1cnrs turn ½ RH | 1cnrs turn LH ; 1c+1cnrs turn back RH ½ | 1c turn LH ¼ to 2cnrs
- 17- Repeat with 2cnrs, 1c crossing LH to 2pl
- 25- 2c+1c+3c circle6 and back

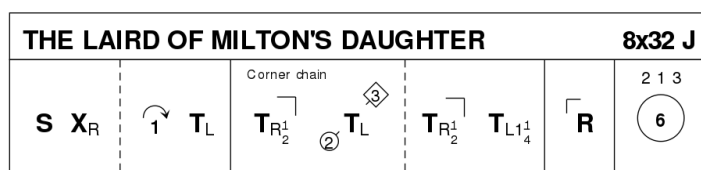

Lord Craigmyle, RSCDS Book 22.10

3C/4C longwise set.

11 BROADFORD BAY R32 · 3/4L

Anne Grant: *The Leaflet Dances with Music* · Crib: *E-cribs* · Diagram: *Keith Rose's Diagrams*

- 1- 1c (leading)+2c (dance up to begin), dance between 3c, cast up and dance to top, and 1c cast off (to 2,1,3)
- 9- 2c+1c+3c G-Chain (2c cross to start), finish 2M & 1W facing out (2,1,3)
- 17- 2W+1M turn RH $1\frac{1}{2}$ while{4} 2M+1W chase $\frac{1}{2}$ round cclw ; 2W+1M chase $\frac{1}{2}$ round clw to 1W/2M places while{4} 2M+1W turn LH $1\frac{1}{4}$ to face P on 2diagonal
- 25- 2c+1c diagonal Reel4 (to 2,1,3)

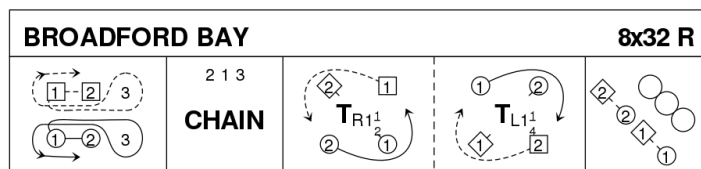

Anne Grant, 1990, RSCDS Leaflet 32

3C/4C longwise set.

12 FAIR DONALD S32 · 3/4L

RSCDS XXIX 4 · Crib: *E-cribs* · Diagram: *Keith Rose's Diagrams*

- 1- 1c dance NHJ between 2c and cast up to top ; dance NHJ between 3c and cast up to 1cnrs (2c up on [7-8])
- 9- Reel4 with 1cnrs, at the end pass Lsh to face 2cnrs
- 17- Reel4 with 2cnrs, finishing between 2c on own side, facing up NHJ
- 25- 1c cast off one | 2c+1c+3c set ; all turn P BH

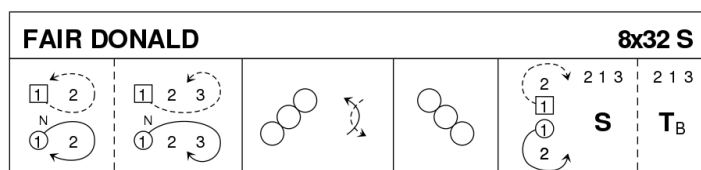

RSCDS Book 29.4

3C/4C longwise set.

13 MISS JOHNSTONE OF ARDROSSAN R32 · 5/5L

Roy Goldring: *14 Social Dances for 2000* · Crib: *E-cribs* · Diagram: *Keith Rose's Diagrams*

- 1- 1c set | cast off (2c up) ; 1c followed by 3c dance up and cast round 2c to (2,3,1,4,5)
- 9- 1c+4c+5c mirror Reels3, 1c cross down to enter, 4c start out and up (2,3,1x,4,5)
- 17- 2c+3c+1c mirror Reels3, 1c cross up to enter, 3c start out and down
- 25- 1c set | cast off to 4pl (4c up) ; 1c followed by 5c dance up and cast round 4c to (2,3,4,5,1)

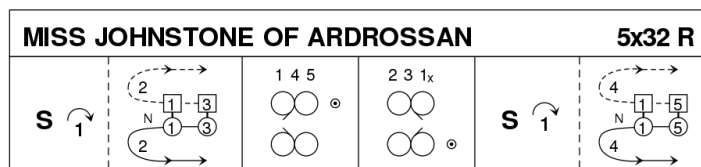

Roy Goldring, 2000, 14 Social Dances for 2000

5C/5C longwise set.

14 THE WEATHERCOCK J32 · 4/4L

Veronica Hughes: *A Second Book of Graded Scottish Country Dances* · Crib: *E-cribs* · Diagram: *Keith Rose's Diagrams*

- 1- Parallel Reels4 on the sides
- 9- 1c+3c set advancing to midline and join RH with P, LH in middle | BiL (2c+4c up) ; 1c+2c & 3c+4c RHA
- 17- 1W+3M turn LH $\frac{3}{4}$ while{} 1M+3W dance round clw $\frac{1}{4}$ to meet P in line across | BiL ; repeat
- 25- 3c+2c & 1c+4c RHA ; 1c+3c turn person ahead (»corner«) RH to finish (2,3,4,1) (M turn once and a bit, W turn $1\frac{1}{2}$ and a bit)

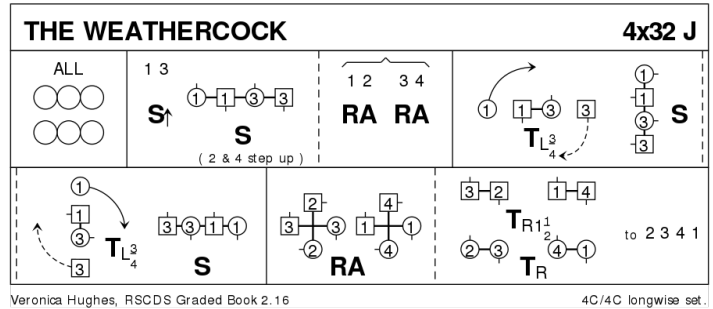

Veronica Hughes, RSCDS Graded Book 2.16

4C/4C longwise set.

note: the set tends to move upwards; ease down gently in the turns to end in the right positions

15 GLASTONBURY TOR R32 · 3/4L

Duncan Brown: *RSCDS XLVII 11* · Crib: *E-cribs* · Diagram: *Keith Rose's Diagrams*

- 1- 1c+2c set | $\frac{1}{2}$ RHA ; 1c+3c set | $\frac{1}{2}$ LHA (2x,3x,1)
- 9- 1c set | cross RH ; cast up one (3c down) | turn LH to face 1cnr (pos)
- 17- $\frac{1}{2}$ diag Reel4 with 1cnrs, pass Lsh ; $\frac{1}{2}$ diag Reel4 with 2cnrs, 1c curve R into facing lines of 3 across, 1M at top, 1W at bottom
- 25- All S&Link3 ; 1c turn RH $1\frac{1}{2}$ while{} 4 cnrs chase clw $\frac{1}{2}$ round (2,1,3)

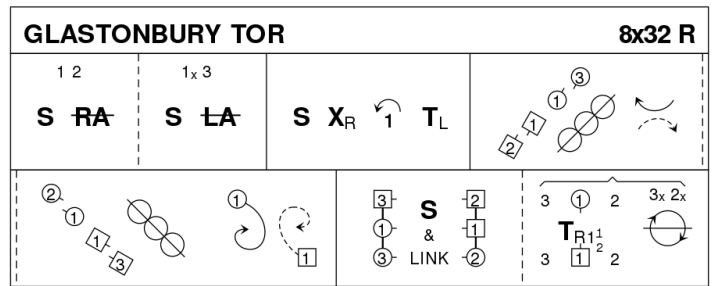

Duncan Brown, 2001, RSCDS Book 47.11

3C/4C longwise set.

16 ANNA HOLDEN'S STRATHSPEY S32 · 2/4L

John Drewry: *RSCDS XLII 2* · Crib: *E-cribs* · Diagram: *Keith Rose's Diagrams*

- 1- 1c+2c RHA (2c face out) ; 1c cross down, while{} 2c cast up | 1M+2W & 2M+1W Turn $\frac{3}{4}$ easy hand to line4 across facing down (1c between 2c)
- 9- All dance down, on [12] 1c turns in and 2c meets, all NHJ ; 1c+2c dance up | 1c cast off to 2plx, while{} 2c dance to 1pl (loop is usual)
- 17- All set | »petronella in tandem« ; repeat (to 1,2x)
- 25- All set | $\frac{1}{2}$ Circle4 Left ; 1c turn BH $1\frac{1}{2}$ to 2pl.

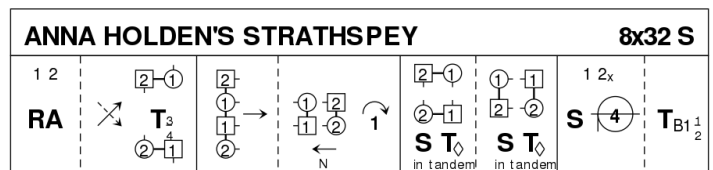

John Drewry, 1991, RSCDS Book 42.2

2C/4C longwise set.

17 THE NURSERYMAN J32 · 3/4L

Stephen Brown: RSCDS XXXVII 7 · Crib: E-cribs · Diagram: Keith Rose's Diagrams

- 1- 1c set | cross down RH (2c up) ; cast behind 3c, dance up NHJ to 2pl BtoB facing opp. side
- 9- 2c+1c+3c set as in DTr | All set advancing and swivel R to form »inverted« DTr (2c+3c are BtoB in centre) ; All set | All set advancing (1c into the middle) into
- 17- 2W+1M+3W & 2M+1W+3M RHA, 1c pass Rsh ; 1W+2W+3W & 1M+2M+3M LHA, finish in lines 1W between 2c facing 1M between 3c
- 25- Lines A&R ; 1c turn RH 1¼ to (2,1,3)

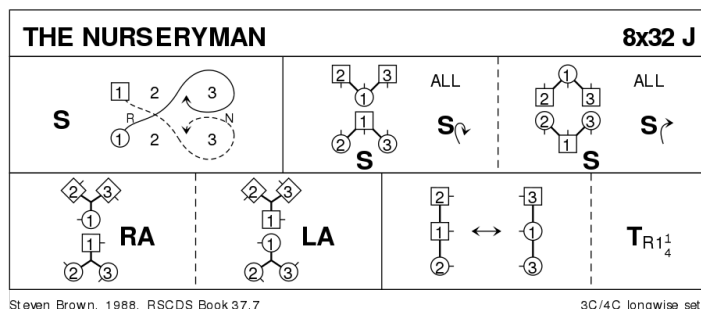

18 THE REEL OF THE ROYAL SCOTS R32 · 3/4L

Roy Goldring: The Leaflet Dances with Music · Crib: E-cribs · Diagram: Keith Rose's Diagrams

- 1- 1W+2W (1M+2M) turn LH (RH) ½, finishing 1c BtoB in 2pl | All set as in DTr ; 1W+3W (1M+3M) turn RH (LH) ½ | 2c+3c+1c set as in DTr
- 9- 1c followed by 3c dance up between 2c, cast off ; dance NHJ down through 3pl, cast up to face 1cnrs, 3c looping into 3pl
- 17- 1c turn 1cnrs RH, pass Rsh (cnrs dance for {4}) ; turn 2cnrs RH (same), and cross Rsh to (2,1,3)
- 25- All circle6 and back

