

Leeds Scottish Country Dance Club 27 January 2018

St Chad's Parish Centre, Otley road, Leeds, LS16 5JT Music: Alan ross Duo MC:
Irene Dracup

1 JOIE DE VIVRE J32 · 3/4L

Irene van Maarseveen: RSCDS XXXIX 2 · Crib: Eric's E-cribs · Diagram: Keith Rose's Diagrams

- 1- 1c set | cast (2c up) ; dance between 3c and cast up to (2,1,3)
- 9- All turn P RH to sidelines ; all chase clw half round (to 3x,1x,2x)
- 17- All dance BtoB ; all set | all ½ RH turn into
- 25- 3c+1c+2c Allemande (2,1,3)

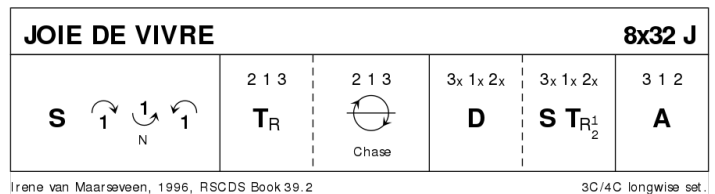

2 THE CUMBRAE REEL R32 · 3/4L

RSCDS XXVIII 8 · Crib: Eric's E-cribs · Diagram: Keith Rose's Diagrams

- 1- 1c+2c half R&L ; 2c cross RH to own side **while**{4} 1c dance up to between 2c, all facing up NHJ | set in line across and pivot R the second PdB to face down
- 9- In line of 4 dance down the middle (turn R about) ; and up, finishing with 1c BtoB between 2c
- 17- 1c+2c Reel4 across the dance, 1c finishing facing corners
- 25- 1c turn corner, P, corner, cross over to own sides (2,1,3)

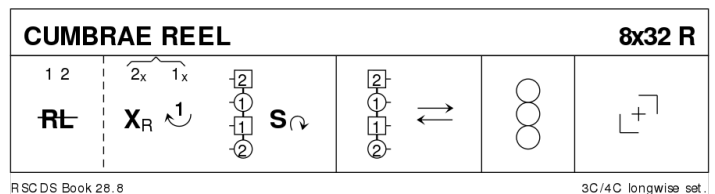

3 BARBARA'S STRATHSPEY S32 · 3/4L

Sue McKinnell: RSCDS XLVI 4 · Crib: Eric's E-cribs · Diagram: Keith Rose's Diagrams

- 1- 1c set | cast (2c up) ; ½ Fig8 L (2,1x,3)
- 9- All set | 1c cross Rsh ; 1c+3cnr turn RH 1½ (to 1,2,3 on M side, 2,3,1 on W side)
- 17- 3C Bourrel: 2W+3M chase cclw half round to midline **while**{4} 1M+3W & 2M+1W set adv | turn BH ¾ and pivot R, all facing P on midline (3,1,2) ; All set | All C turn BH ¾ to sidelines
- 25- All chase clw ½ round ; all turn P RH ½ and twirl R to (2,1,3)

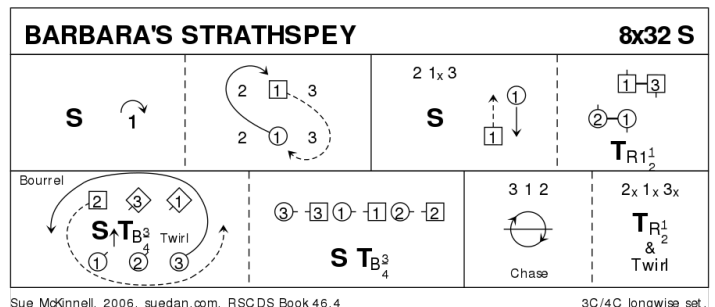

4 PELORUS JACK J32 · 3/4L

Barry Skelton: RSCDS XLI 1 · Crib: Eric's E-cribs · Diagram: Keith Rose's Diagrams

- 1- 1c cross RH, cast (2c up) ; 1c+3c RHA, finish 1M facing 1cnr, 1W behind him
- 9- 1c in tandem +1cnrs ½ diagonal Reel3, Rsh to 3W (1M & 1W loop R singly for lead change, so 1W now leads P) ; ½ diagonal Reel3, Rsh to 2W (+ lead change)
- 17- Continue pattern twice
- 25- 2c+1c LHA ; 1c turn LH ½ | all set (2,1,3)

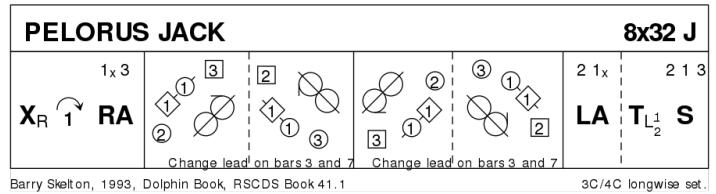

5 BLOOMS OF BON ACCORD R32 · 4/4L

John Drewry: Deeside Book Part 2 · Crib: Eric's E-cribs · Diagram: Keith Rose's Diagrams

3c+4c cross on 2nd chord(1,2,3x,4x). This dance has top/bottom symmetry

- 1- All C set | 1c+2c & 3c+4c RHA | 1c & 4c cast in to 2pl/3pl **while**{2} 2c+3c lead out to end places
- 9- 1c+4c cross RH, cast to ends, meet in promhold and dance in between end couples, curve round the other couple Rsh to finish 1c / 4c on M/W side facing out and right
- 17- 1c & 4c (in promhold) Rsh Reels3 with the »corners« on M/W sides, at end meet in the centre
- 25- 4c+1c RHA, at end M swivels right so couples face ends of set (1c down, 4c up, W on P's left, RHJ) ; 4c&1c cross down between end couples and cast in to 3pl/2pl (to 2,4,1x,3x)

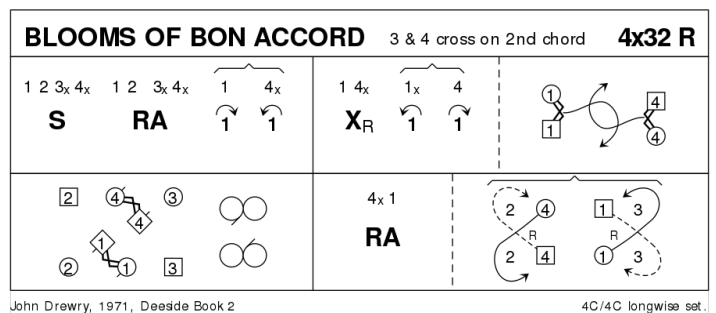

6 SEAGREEN S32 · 3/3L

John Drewry: The Brodie Book · Crib: Eric's E-cribs · Diagram: Keith Rose's Diagrams

- 1- 1c+2c+3c set | {1M+3W petronella-turn to finish BtoB between 2c with 1M facing up and 3W facing down ; dance through P's place | cast R to exchanged places} **while**{6} {1W+3M cast clw to other end ; petronella to finish BtoB with 3M facing up and 1W facing down | both dance out to exchanged places (3x,2,1x)
- 9- All set, circle6 L. On [14], all drop hands, dance into the centre pulling Rsh back to face out, and dance clw to starting places (3x,2,1x)
- 17- 3c+2c+1c repeat figure [1-8] to (1,2,3)
- 25- 2c followed by 1c dance down NHJ between 3c and cast up to 1pl / 2pl ; 1c with 3c following dance up NHJ between 2c and cast off to 3pl / 2pl (to 2,3,1)

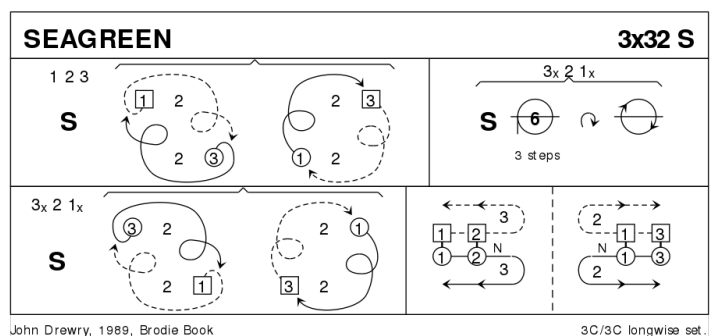

7 LINKS WITH ST PETERSBURG J32 · 3/4L

Malcolm Brown: RSCDS XLVI 10 · Crib: Eric's E-cribs · Diagram: Keith Rose's Diagrams

- 1- 1c+2c S&Link, finish 2c facing 1c NHJ ; S&Link to (2x,1x,3)
- 9- 1c, 2c following, dance down {3}, change sides with NHJ, W passing above M and under his arm, 2c+1c dance up to (2,1,3), 2c facing out
- 17- 2c turn 1c EH on sides ; 1c turn 3c EH, 1c finish BtoB facing 1cnr
- 25- SetH&G , petronella to (2,1,3)

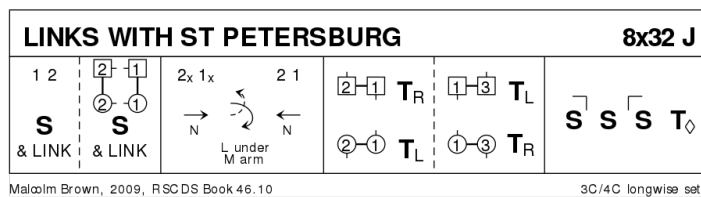

8 THE LADIES OF DUNSE R40 · 3/4L

RSCDS XXVI 11 · Crib: Eric's E-cribs · Diagram: Keith Rose's Diagrams

- 1- 1c lead down the middle and up {6}, cast off (2c up)
- 9- 2c repeat (1,2,3)
- 17- 2c (1c following) cross down into a Fig8 round 3c, to finish (2,1,3)
- 25- 1c+3c R&L, finish facing 1cnrs (1M has no polite turn)
- 33- 1c set to 1cnr, to 2cnr, pulling Rsh back to sideline facing P ; turn RH 1½ to (2,1,3).

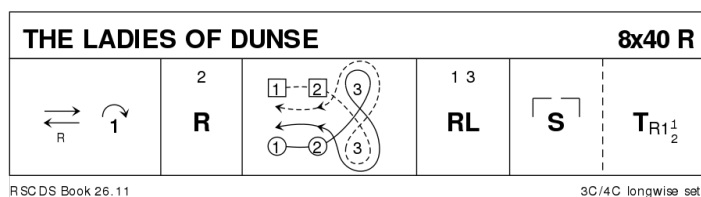

9 PROGRAMME ITEM – Interval

10 EH3 7AF J32 · 3/4L

Roy Goldring: RSCDS XL 6 · Crib: Eric's E-cribs · Diagram: Keith Rose's Diagrams

- 1- 1c lead down the middle and up, on [8] 2c+3c step in for
- 9- 1c+2c+3c Promenade, at end 1c cast off (to 2,1,3)
- 17- 1c cross Rsh | turn 1cnr RH ; cross up/dn Rsh | turn 2cnr RH (2,1x,3) |
- 25- 2c+1M & 1W+3c RHA ; 1c ½Fig 8 Rsh round 4cnr (2,1,3)

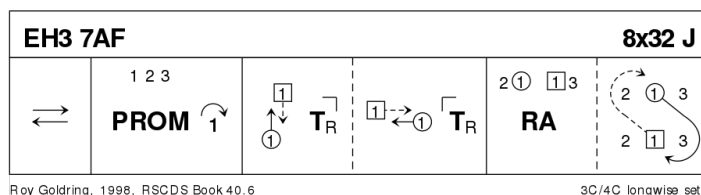

11 CALLER HERRIN' R40 · 3/4L

Hugh Foss: Dances To Song Tunes · Crib: Eric's E-cribs · Diagram: Keith Rose's Diagrams

- 1- 1W+2M & 1M+2W set (1c advancing and passing Rsh) and turn EH to face P ; repeat figure (again 1c passing) to own places, 2c facing out
- 9- 1c followed by 2c (cast up) lead down between 3c, cast up on own side, dance up NHJ to own places (1c loops, 2c dances straight in) | 1c+2c set (1,2,3)
- 17- Reels3 on own side, 1c starts in, 2c out and up, Touch hands every time in the middle (1,2,3)
- 25- 6 bars of Reels3{8} on sides, all crossing from top (1c on [1], 2c on [3], 3c cross at top on [5-6] (to 3x,1x,2x) | all set (3,1,2)
- 33- 2c+3c cross RH, set up/down ; 2c (passing outside)+3c change places EH **while**{2} 1c cast off one | cross RH ; cast up to 2pl | all set (2,1,3)

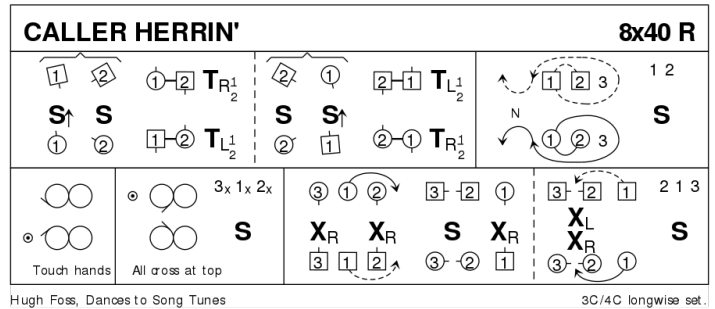

12 SANDS OF MORAR S32 · 3/4L

Barry Priddy: RSCDS XLV 6 · Crib: Eric's E-cribs · Diagram: Keith Rose's Diagrams

- 1- 1c Fig8 round 2c, giving hands
- 9- All Mirror Reels3 on own side, 1c starts in, join hands on meeting P
- 17- 1c turn BH | 1c dance to 3pl NHJ **while**{4} 2c+3c continue reel to top and follow behind 1c ; 3c+2c+1c set facing down | 1c cast to top, 2c+3c following to finish (1,2,3)
- 25- 1c+2c Tourbillon (1c+2c turn P BH ½, opening out to one place clw in the square (1c to W side, 2c to M side) | 1c set to 2c ; repeat figure (to 2x,1x) | 2c+1c cross RH) (2,1,3)

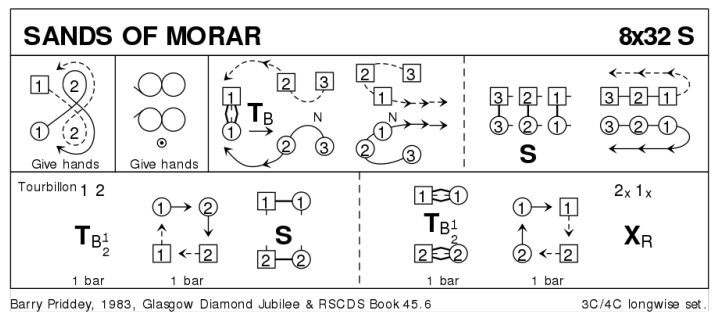

13 VINTAGE SIMON J32 · 5/5L

Dorothy Hargreaves: RSCDS XLVII 5 · Crib: Eric's E-cribs · Diagram: Keith Rose's Diagrams

- 1- 1c+5c turn RH ½ | Chase clw (1M & 5W leading) behind sideline to 4pl/2pl | turn P RH to face 1cnr **while**{8} 3c set | dance up (2c+4c step down) ; and curve into 1pl | set (3,5,2,1,4)
- 9- Corners Chain with setting: 1c&5c change place RH with 1cnr | cnrs turn LH as 1c+5c set ; change back with cnr | turn LH 1¼ to face 2cnr
- 17- Repeat with 2cnr, at end 5c+1c turn P LH to finish on midline facing own side, M above W (3,5,2,1,4)
- 25- RHA in pattern 3-4-3 ; 5c+1c BiL on midline | turn P LH ¾ to (3,5,2,1,4)

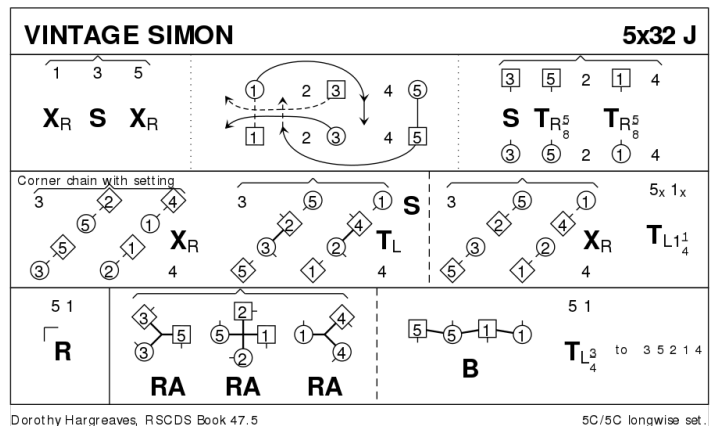

14 THE PIPER AND THE PENGUIN

R88 · 4S

Roy Goldring: *The Scotia Suite of Scottish Country Dances* · Crib: *Eric's E-cribs* · Diagram: *Keith Rose's Diagrams*

- 1-16 All W dance Rsh round cnr ; RHA in middle ; Lsh round P ; LHA in middle, to places
- 17-32 All M dance Rsh round P ; RHA in middle ; Lsh round cnr ; LHA in middle, to places
- 33-48 1c+3c turn RH 1¼ ; 1M & 3M (W following) dance between couple on the R and cast clw to places ; 1c+3c R&L
- 49-64 2c+4c repeat
- 65- All W dance into middle, swivel R and dance through own place clw half way round set
- 73- All M dance into middle, swivel L and dance through own place cclw half way round set
- 81- All turn P RH 1¼ ; promenade cclw half way round set, to own places

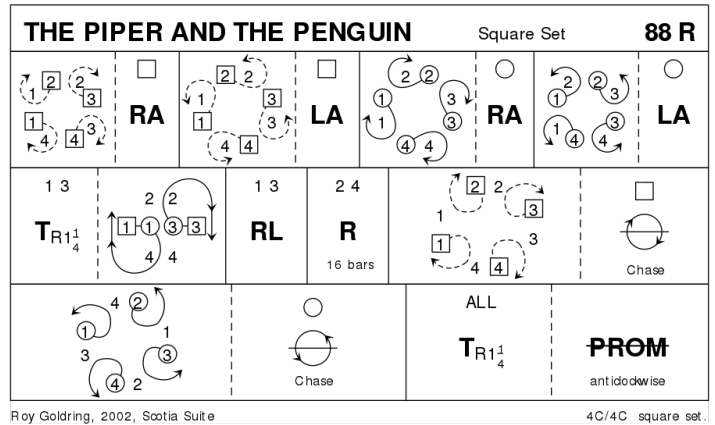

15 THE CORIAN STRATHSPEY

S32 · 3/3L

Maurice Whitby: *RSCDS XLIII 8* · Crib: *Eric's E-cribs* · Diagram: *Keith Rose's Diagrams*

- 1- 1M+2W turn RH 1½ while{4} partners chase round them cclw ½ (to 2x,1x,3) ; 1c ½ Fig8 down round 3c (2x,1,3)
- 9- 1W+3M turn LH 1½ while{4} partners chase round them clw ½ (to 2x,3x,1x) ; 3c ½ Fig8 up round 2c (2x,3,1x)
- 17- All set | 3c petronella into facing lines across (3W with 2c, 3M with 1c) ; S&Link3 (2,3,1), 3c dancing into the middle for
- 25- Teapots R (2c+3W & 3M+1c RHA) ; Teapots L (2c+3M & 3W+1c LHA) (2,3,1)

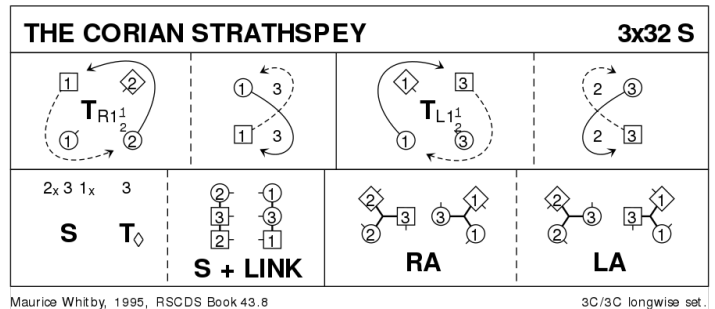

16 SCOTT MEIKLE

R32 · 4/4L

Alice McLean: *RSCDS XLVI 3* · Crib: *Eric's E-cribs* · Diagram: *Keith Rose's Diagrams*

- 1- 1c cross RH | cast (2c up) ; ½ Fig8 up (2,1,3,4)
- 9- 1c+3c RHA, LHA (2,1,3,4)
- 17- Lsh opposing Reels3 across: (1W+3W behind dancing as one) with 2c and (3M+1M behind) with 4c (to 2,3,1,4)
- 25- 1c+4c ½ R&L ; turn RH 1½ (2,3,4,1)

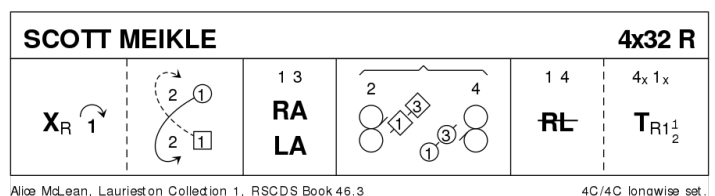

17 BILL CLEMENT MBE J32 · 3/4L

John Wilkinson: RSCDS XLVII 1 · Crib: Eric's E-cribs · Diagram: Keith Rose's Diagrams

- 1- 1c set | dance between 3c (2c up) and cast up to finish side by side LHJ facing 1cnr
- 9- Set to 1cnr and turn inwards and join RH | set to 3cnr ; turn 3cnr LH to face 2cnr RHJ
- 17- Set to 2cnr and turn inwards and join LH | set to 4cnr ; turn 4cnr RH to (2,1,3)
- 25- Circle6 and back

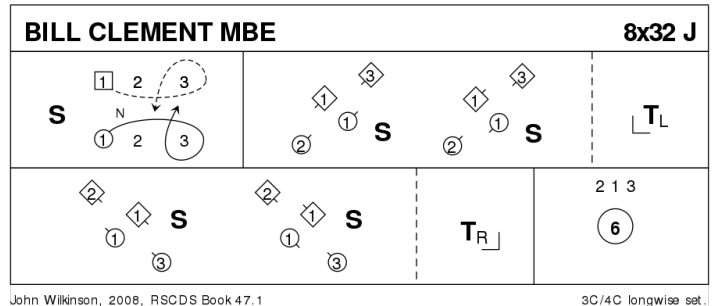

18 PROGRAMME ITEM – Extras

19 SUNSHINE AND SWEETIE'S JIG J32 · 3/4L

Mervyn C Short: RSCDS XLVIII 7 · Crib: Eric's E-cribs · Diagram: Keith Rose's Diagrams

- 1- 1c+2c set | ½ RHA ; set | cross RH (2,1,3)
- 9- 1c turn 1cnr RH and face 1cnr ; ½ Reel4 on 1diag, 1c finish on sides in 2pl
- 17- 1c turn 2cnr LH and face 2cnr ; ½ Lsh Reel4 on 2diag, finish on sides (3x,1,2x)
- 25- All chase ½ cclw ; 1c set | cross RH (2,1,3)

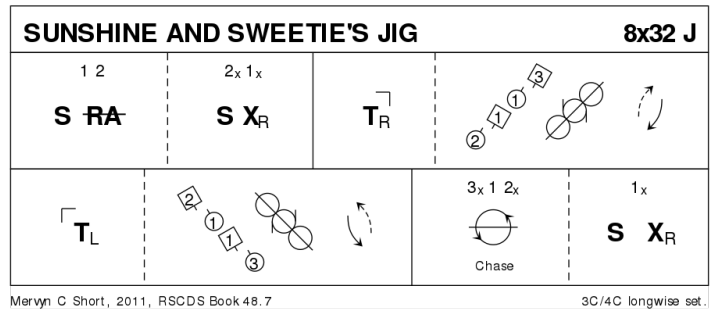

20 LIQUID ASSETS J32 · 3/4L

John Drewry: Stoneywood Collection Volume 2 · Crib: Eric's E-cribs · Diagram: Keith Rose's Diagrams

- 1-- 1c cross down into Mirror Reels3 on opposite side (1x,2,3), 2c facing out
- 9-- 1c turn 2c on sideline EH 1½ (2,1x,3) ; 1c+3c repeat (2,3,1x), 3c facing out
- 17-- 1c cross up into Mirror Reels3 on own side (2,3,1), 3c facing out
- 25-- 1c turn 3c on sideline EH 1½ (2,1,3) ; 1c dance up between 2c and cast off to (2,1,3)

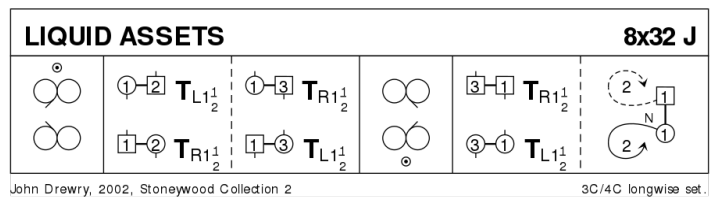

21 CITY OF BELFAST S32 · 3/3L

Lucy Mulholland: RSCDS XLVIII 6 · Crib: Eric's E-cribs · Diagram: Keith Rose's Diagrams

- 1- 1c ½ Fig8 round 2c ; 1c turn 2c EH 1¼ into line across, 1c in the middle
- 9- 1c+2c Reel4, finish 2c in 1pl and 1c (last pass is Lsh) facing 1cnr
- 17- 1c set to 1cnr | set to 2cnr, dancing R into sideline (2,1x,3) ; All set | 1c cross RH
- 25- 1c+3c Espagnole (2,3,1)

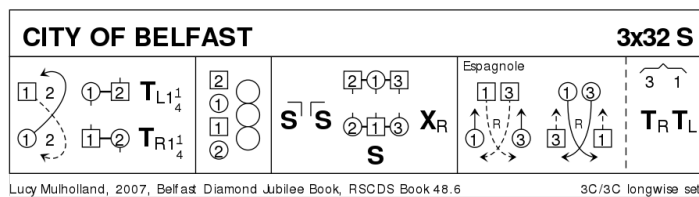

Espagnole: both W lead RHJ to M side, cross and cast back to exchanged places while Men cross to W side, lead RHJ back to M side crossing to exchanged places ; all turn P EH (2,1)