

# Hogmany Dance 2019

Hogmany Dance Friday 27 December 2019, West Park United Reformed Church,  
Spenn Lane, LS16 5BD

Music Ian Slater MC: Don Andrews

## 1 WELCOME TO AYR J32 · 3/4L

Jill Hendricksen/Kathy Stewart: RSCDS XLVII 8 · Crib: E-cribs · Diagram: Keith Rose's Diagrams

- 1- 1c+2c DbIFig8, 1c crossing down to start, at end 2c face out
- 9- 1c+2c turn EH 1¼ on side (2c to 1pl) and 1c face down NHJ ; 1c dance down and turn 3c EH, 3c finish in 3pl and 1c facing 1cnr
- 17- 1c+1cnrs ½ diag. Reel4 and pass Rsh ; repeat with 2cnrs, 1c finish on midline Lsh to Lsh facing own side
- 25- 3c+1M & 1W+2c RHA (3x,1x,2x) ; All chase clw ½ round (2,1,3)

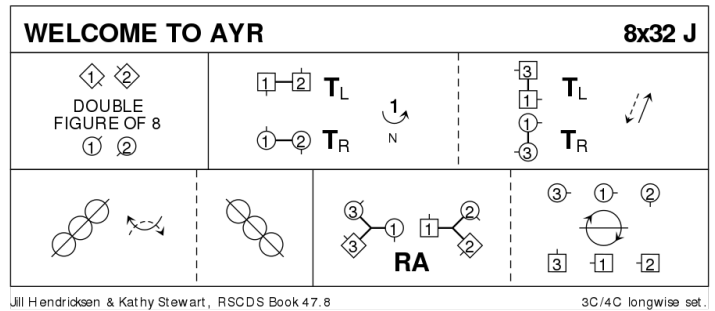

## 2 LINKS WITH ST PETERSBURG J32 · 3/4L

Malcolm Brown: RSCDS XLVI 10 · Crib: E-cribs · Diagram: Keith Rose's Diagrams

- 1- 1c+2c S&Link, finish 2c facing 1c NHJ ; S&Link to (2x,1x,3)
- 9- 1c, 2c following, dance down {3}, change sides with NHJ, W passing above M and under his arm, 2c+1c dance up to (2,1,3), 2c facing out
- 17- 2c turn 1c EH on sides ; 1c turn 3c EH, 1c finish BtoB facing 1cnr
- 25- SetH&G , petronella to (2,1,3)

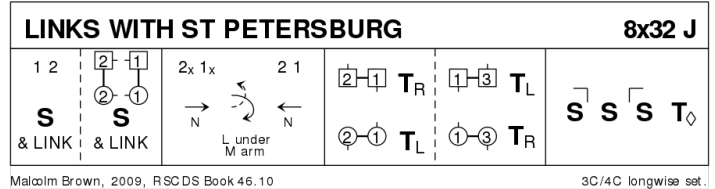

### 3 AUTUMN IN APPIN S32 · 4/4L

John Drewry: RSCDS XXXI 5 · Crib: E-cribs · Diagram: Keith Rose's Diagrams

On 2nd chord 3c+4c change sides to 1,2,3x,4x.  
Centro-symmetrical dance.

- 1- 2c+3c Petronella Turn and set ; turn  $\frac{3}{4}$  RH into  $\frac{1}{2}$ RHA to form pairs in promhold facing out (3W+2M on M side ; 2W+3M on W side).
- 9- 1c+4c Petronella Turn | set ;  $\frac{1}{2}$  RH turn and Promenade clw to the side positions, forming a square set **while** {8} the pairs cast R | pass between end Cs ; Promenade clw to other end
- 17- 1c+4c  $\frac{1}{2}$  L-Chain across ; the pairs  $\frac{1}{2}$  M-Chain, finishing with a full RH turn to put M on the right of P (2c at top, 3c at bottom)
- 25- All set |  $\frac{1}{2}$  circle8 L {3}, dance in on L foot into centre and all swivel R {1} | spiral out into longwise set (2,4,1x,3x)

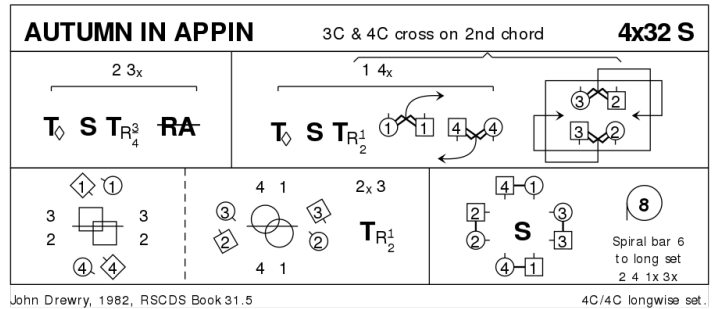

### 4 THE CLANSMAN R32 · 2/4L

Derek Haynes: RSCDS XXXII 8 · Crib: E-cribs · Diagram: Keith Rose's Diagrams

- 1- 1c cross RH | cast off (2c up) ; 2c+1c  $\frac{1}{2}$  RHA | set to P (1,2x)
- 9- 1c+2c R&L, finish with  $\frac{3}{4}$  LH turn into line across, the W in the centre:
- 17- The Targe (1W+2W turn  $\frac{3}{4}$  RH **while** {2} 1M+2M chase  $\frac{1}{4}$  round cclw | 1M+2W & 1W+2M Turn LH ; repeat) finishing on sides (2,1x)
- 25- 2c facing 1c set | all set to P ; 1c lead up, cross and cast to 2pl (2,1)

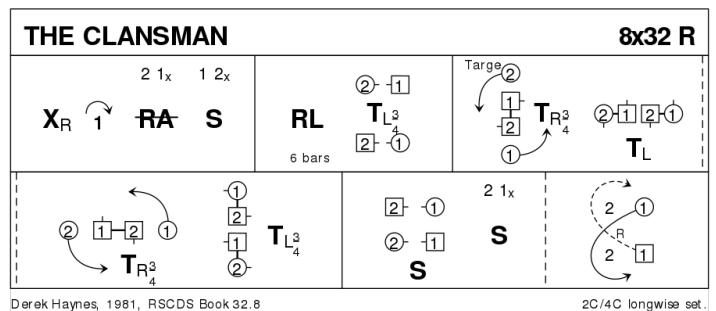

### 5 JIM'S HABERDASHERY J40 · 3/4L

Alan Macpherson: Bannockburn 700 · Crib: E-cribs · Diagram: Keith Rose's Diagrams

- 1-- 1c+2c DbIFig8, 2c begins out and up
- 9-- 1c+2c turn EH  $1\frac{1}{2}$  on sidelines ; cast off behind 3c and cross up to (2,1x,3)
- 17-- Mirror Reels3 on the sides, 1c starts out and up , At the end 1c cross to (2,1,3)
- 25-- Mirror Reels3 on the sides, 1c starts out and up , At the end 1c face up NHJ between 3c
- 33-- 1c dance to top, cast off ; All turn P RH (2,1,3)

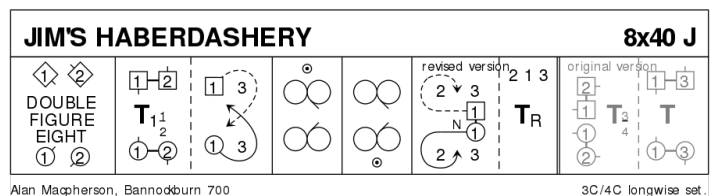

The deviser prefers his original [33-40]: 1c dance up and turn 2c EH (2,1,3) ; 1c turn 3c other hand (2,1,3)

## 6 THE MORAY RANT S48 · 3/3L

John Drewry: Silver City Book of SCD · Crib: E-cribs · Diagram: Keith Rose's Diagrams

- 1- Inveran reels{6} (1c cross down from top, cross up from bottom) | 1c cross RH to (1x,2,3)
- 9- 1c set advancing | turn BH ; dance down between 2c, cast behind 3c, finish BtoB between 3c facing opp. side
- 17- 1M+3W & 1W+3M set & turn EH  $\frac{3}{4}$  (1c start out between 2c and 3c) ; 1c dance up , cast up behind 2c, finish BtoB between 2c facing opp. side
- 25- 1M+2W & 1W+2M set & turn EH  $\frac{3}{4}$  (1c start out between 2c and 3c) ; 1c  $\frac{1}{2}$ Fig8 round 2c to (1,2,3)
- 33- 1c+2c Circle4 L ; 1c facing 2c NHJ set and 1c face up | 1c cast off **while{2}** 2c lead up (2,1,3)
- 41- 1c+3c repeat [33-40] to (2,3,1)

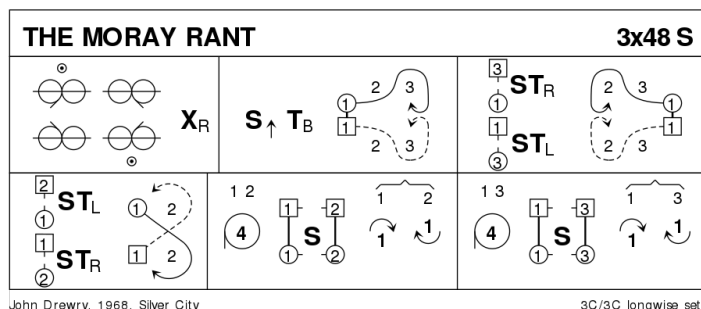

## 7 GLASTONBURY TOR R32 · 3/4L

Duncan Brown: RSCDS XLVII 11 · Crib: E-cribs · Diagram: Keith Rose's Diagrams

- 1- 1c+2c set |  $\frac{1}{2}$  RHA ; 1c+3c set |  $\frac{1}{2}$  LHA (2x,3x,1)
- 9- 1c set | cross RH ; cast up one (3c down) | turn LH to face 1cnr (pos)
- 17-  $\frac{1}{2}$  diag Reel4 with 1cnrs, pass Lsh ;  $\frac{1}{2}$  diag Reel4 with 2cnrs, 1c curve R into facing lines of 3 across, 1M at top, 1W at bottom
- 25- All S&Link3 ; 1c turn RH  $1\frac{1}{2}$  **while{4}** cnrs chase clw  $\frac{1}{2}$  round (2,1,3)

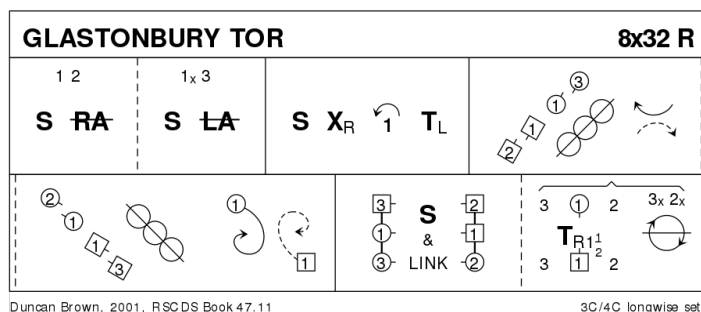

## 8 MAJOR IAN STEWART J32 · 3/4L

John Drewry: RSCDS XXXV 4 · Crib: E-cribs · Diagram: Keith Rose's Diagrams

- 1- 1c+2c turn RH  $\frac{1}{2}$  into |  $\frac{1}{2}$  RHA into ; 2c+1c turn RH, 2c finish facing out (2,1,3)
- 9- Opposing Reels3 on own sides (1c inwards, Rsh to 4cnr) 1c finish facing 1cnr, 2c+3c finish with loops
- 17- SetH&G to (2,1,3)
- 25- Circle6 L {3}, cross R foot over L and chase back cclw to (2,1,3)

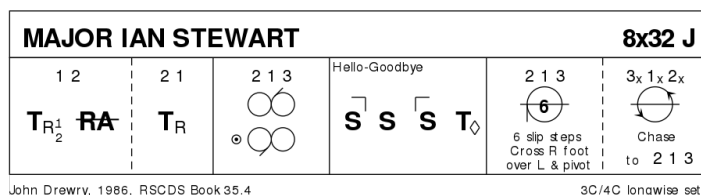

## 9 PROGRAMME ITEM – Supper

## 10 THE FIRST RAIN OF SPRING

J32 · 3/3L

Wouter Joubert: RSCDS XLIX 4 · Crib: E-cribs · Diagram: Keith Rose's Diagrams

- 1-- 1c dance down below 3c | cast up 1 place ; dance up to 1pl facing out | 1c+2c ½ turn EH, 2c face out
- 9-- 2c+1c DbIFig8, 1c crossing up
- 17-20 1c+3c turn P RH ¾ and face P up/dn | set ;
- 21-28 (½ Celtic Reel) 1c+3c pass Rsh | "outers" chase ¼ way clw **while{2}** "inners" turn (no hands) ¾ Lsh to face same person ; repeat
- 29-32 1c+3c Turn P RH ¾ | all set

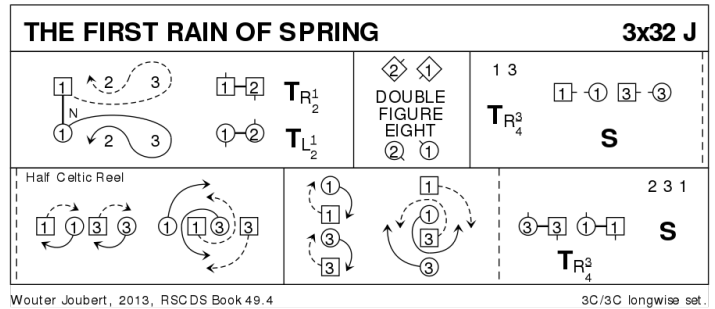

## 11 THE COUNTESS OF DUNMORE'S REEL

R32 · 3/4L

Deirdre MacCuish Bark: RSCDS XLIX 12 · Crib: E-cribs · Diagram: Keith Rose's Diagrams

- 1-- 1c set | dance down (2c up) ; cast up round 3c | set advancing to face 1cnr
- 9-- 1c turn 1cnr RH, pass Rsh; turn 2cns RH, pass Rsh to face out in 2pl (cnrs dance for {4}) (2,1,3)
- 17-- [3C Chain Progression] 1c cast ¼ clw round set **while** 2c & 3c Turn RH ¾ | 2M+3W turn LH 1½ **while{4}** the others promenade clw ½ round set | 3c+2c turn RH ¾ **while** 1c dance clw to 2pl (3,1,2)
- 25-- all chase ½ way clw ; set | cross RH (2,1,3)

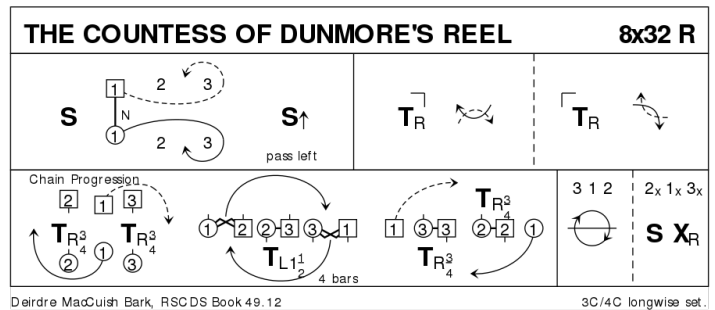

3C Chain Progression was earlier known as Chaperoned Chain Progression

## 12 THE ORCHARDS OF CO. ARMAGH

S32 · 3/3L

Jinty Anderson: Belfast Branch Platinum Anniversary Dances · Crib: MiniCribs · Diagram: Keith Rose's Diagrams

- 1-8 1M leading 2M+3M also 3L leading 2L+1L chase clockwise 1/2 round to opp sides (4 bars). All set, 1s+3s turn partners 3/4 RH into line up/down (Men facing down)
- 9-12 3s+1s dance 1/2 reel of 4, 1M+3L pass LSH to face 2s (1M+2M & 3L+2L facing), 1L+3M remain in centre at top/bottom
- 13-16 1M+3L+2s dance 1/2 reel of 4 across, 1M & 3L pass LSh to face partners up/down set
- 17-24 1s+3s dance 1/2 reel of 4, 1M+3L pass LSh to face own partners. 3s+1s set, petronella turn to own sides. 3 2 1
- 25-32 2s followed by 1s dance up to top, cast, 2s to 3rd place, 1s to 2nd place (4 bars). 3s+1s+2s turn partners 2H

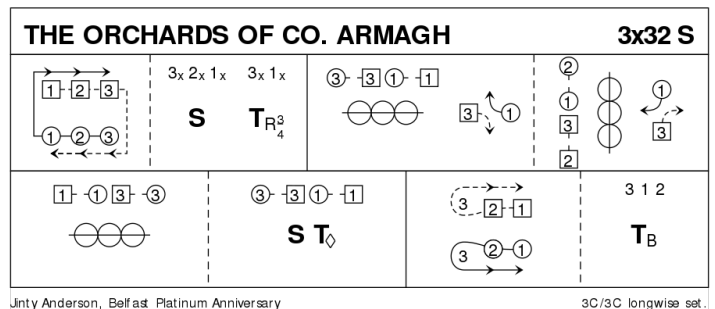

## 13 JENNIFER'S JIG J32 · 3/4L

John Drewry: *Bon Accord Book of Scottish Country Dances · Crib: E-cribs · Diagram: Keith Rose's Diagrams*

- 1- 1c+2c+3c set | cross RH ; repeat & 2c face out
- 9- 1c+2c DbIFig8 (1c cross down), at end 2c face out and up (1,2,3)
- 17- 1c+2c+3c Inveran reels (1c cross down, and cross up from the bottom, 2c+3c full reel3 on own side) (1,2,3)
- 25- 1c with 2c following lead down {3}, turn RH ½ {1} ; turn on ½ moving upwards | 2c+1c lead up (to 2,1,3)

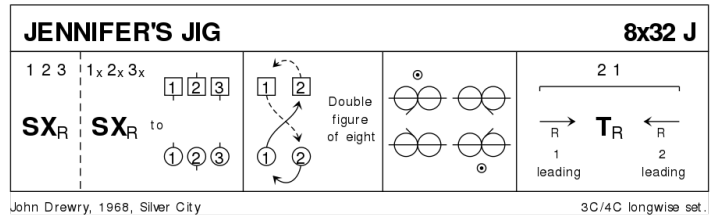

## 14 FORTY AND COUNTING R40 · 3/4L

Malcolm Brown: *RSCDS LII 4 · Crib: MiniCribs · Diagram: Keith Rose's Diagrams*

- 1-8 1s set, cast (2s step up) & turn 1.1/4 LH to face 1st corners
- 9-16 1s dance Chain Progression for 3 couples on the diagonal:  
 9-10 1s change places RH with 1st corners **while** 2nd corners chase 1 place clockwise  
 11-14 1st corners turn 1.1/2 LH in centre **while** 1s & 2nd corners promenade 1/2 round (corners on outside)  
 15-16 2nd corners chase 1 place back to place **while** 1s change places RH with 1st corners. 1s end facing 4th corners
- 17-24 1s dance "Hello-Goodbye" setting ending facing 2nd corners
- 25-32 1s repeat Chain Progression for 3 couples with 2nd corners & end facing 1st corner positions
- 33-40 1s dance 1/2 diag reel of 4 with 1st corners, pass RSh & dance 1/2 diag reel of 4 with 2nd corners ending in 2nd place own side

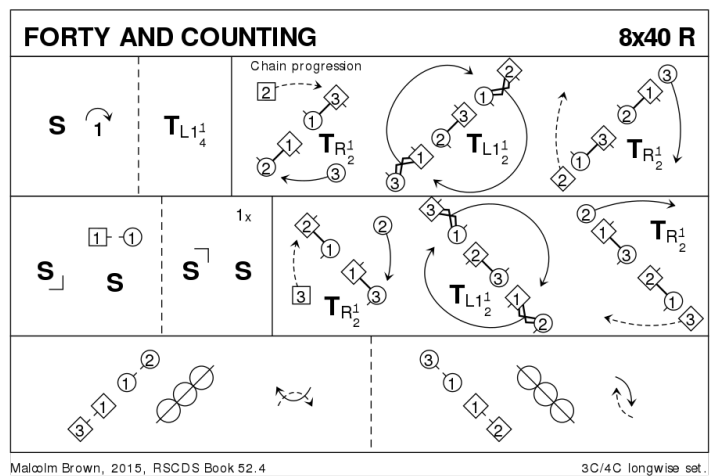

## 15 THE MINISTER ON THE LOCH S32 · 3/3L

Roy Goldring: *Magazine Dances 2005-2009 · Crib: E-cribs · Diagram: Keith Rose's Diagrams*

- 1- 1c+2c Pousette
- 9- 1c dance down 2 places, turn BH ; dance up 2 places, turn BH, open upwards and face out
- 17- 1c+3c DbIFig8 round 2c, 1c casting, 3c crossing up to begin, 1c finish facing out for
- 25- 1W+2W & 1M+2M turn EH 1½ ; 1c+3c repeat (2,3,1)

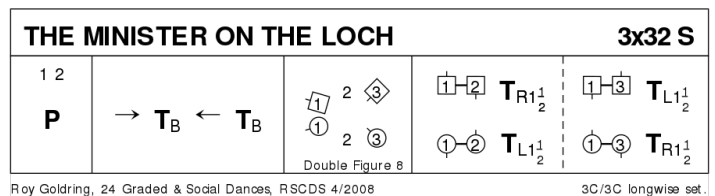

# 16 IAN POWRIE'S FAREWELL TO AUCHTERARDER

J128 · 4S

Bill Hamilton: 90 - Twelve anniversary dances celebrating ninety years of RSCDS Edinburgh Branch 13 · Crib: E-cribs · Diagram: Keith Rose's Diagrams

- 1-- Circle8 L and back
- 9-- All W pass in front of P, dance behind next M ; RHA in the centre
- 17-- All W cross in front of opposite M, dance behind next M ; RHA, joining P for
- 25-- All Promenade once round clw (but see note)
- 33-- 1c+3c (W following M) dance on 1 place clw and in (M round M, W round W) to face next couple ; set to and turn that person RH
- 41-- Reels4 across
- 49-- Fig8, 1c round 2c, 3c round 4c
- 57-- 1c+3c LHA ; 1c/3c dance out Lsh round 2c/4c (M round M, W round W) and cclw to places
- 65--96 2c+4c repeat bars 33-64
- 97-- All Promenade once round cclw
- 105-120 The Men repeat [9-24] cclw with LHA in the centre
- 121-- Circle8 RIGHT and back (see note)

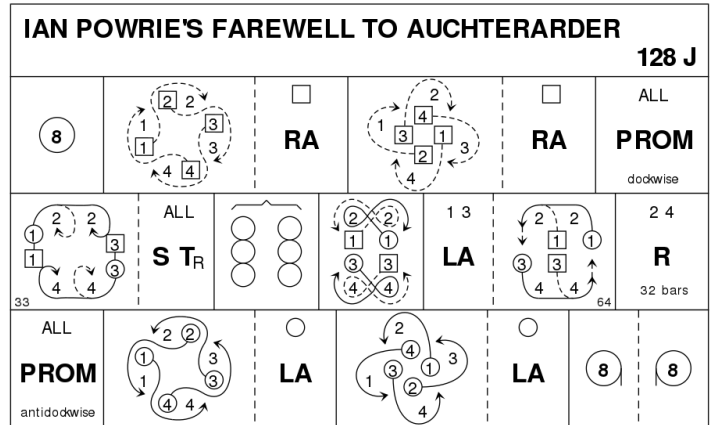

Bill Hamilton, Ian Powrie's Farewell to Auchterarder, Edinburgh 90th 4C/4C square set.

Note: This crib follows the current way of dancing. In the original instructions, the promenade [25-32] is cclw. Bill Hamilton said in 'hindsight' this promenade should be clw, but preferred not to change the official instructions. Bill disapproved of another variant, where the circle [121-128] is continued to the R only.

# 17 THE BLACK BEAR R32 · 3/4L

Ian Galbraith: Berkhamsted Strathspey and Reel Club Golden Jubilee 1952-2002 · Crib: E-cribs · Diagram: Keith Rose's Diagrams

- 1- 1c+2c set | ½ RHA ; Set, 2c cross LH and 1c turn LH to face 1cnr
- 9- SetH&G , finish facing 3cnr
- 17- ½Reel4 on 1diag, pass Rsh to face 4cnr ; ½Reel4 on 2diag, finish (3x,1,2x)
- 25- Diagonal ½R&L with 1cnrs ; repeat with 2cnrs

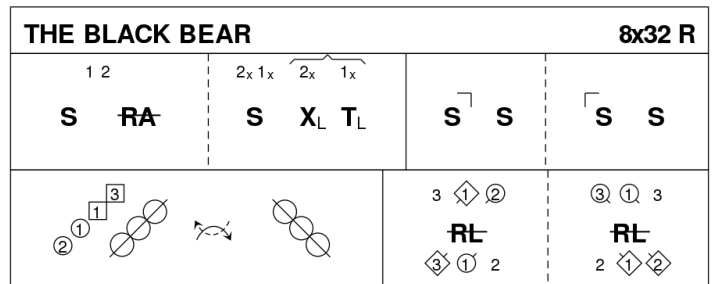

Ian Galbraith, Berkhamsted Golden Jubilee 1952-2002 3C/4C longwise set.

# 18 PROGRAMME ITEM – Extras

# 19 FATHER CONNELLY'S JIG J64 · 4/4L

John Drewry: *The Donside Book* · Crib: *E-cribs* · Diagram: *Keith Rose's Diagrams*

- 1- 1c+2c Set&Rotate (All set | petronella clw one place ; change places RH with P | chase one place clw) (2,1,3,4)
- 9- ½ diagonal R&L with 1cnrs (W up, M down) **while**{4} the 2cnrs (2M+3W) set & cross RH, all cnrs face out ; ½ Reels3 on the sides, 1c Rsh to 2cncr pos. (no loops at the end) (2x,1x,3x,4)
- 17- Repeat figure from these positions with 2cncr persons (in 3cncr positions ; M up, W down) (to 2,1,3,4), 2c+3c finishing with loops into
- 25- Reels3 across (Lsh to 1cncr) (2,1,3,4)
- 33- 1c cross down RH between 3c | cast Rsh round new 1cncr (4W resp. 3M) ; change places up/dn LH | cast L (3c up) to (2,3,1,4)
- 41-56 3c+1c+4c repeat the figures [9-24] above (2,3,1,4)
- 57- 3c+1c+4c Circle6 and back (optional: 2c join in for Circle8 and back) (1c step down, to 2,3,4,1)

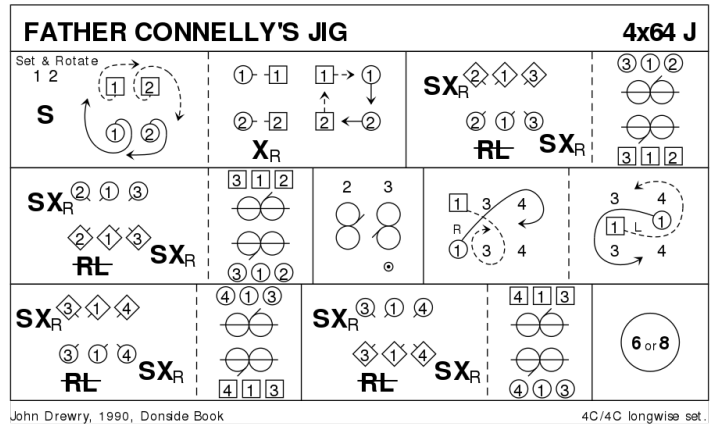

John Drewry, 1990, *Donside Book*

4C/4C longwise set.

(note by Drewry: This is really two successive 3c dances of 32 bars, the figures of bars 9-24 being similar.)