

Hogmany Dance 27 December 2018

7.30pm to 10.30pm

West Park URC, Spen Lane, Leeds, LS16 5BD

Music : Ian Slater MC: Don Andrews

£10-pay at the door

FAITH SUPPER (Finger food please. The United Reform Church has a no alcohol policy, please respect this)

1 THE RAVEN'S DANCE J32 · 3/4L

Derek Haynes: Carnforth Collection of SC Dances 5 · Crib: E-cribs · Diagram: Keith Rose's Diagrams

- 1- 1c+2c DblFig8 (1c cross down, 2c dance up, no cast), at the end 2c face out
- 9- Crossover Reels3 on the sides (1c cross down, 2c out and up), finish 1c side by side at top facing down, W on the R, 2c facing out
- 17- 1c (together) +2c Lead-change Reel3 across, Rsh to 2M. 2c finish in 1pl with 1c in between facing down
- 25- 1c dance down, cast up round 3c, lead up, cross between 2c and cast off (2,1,3)

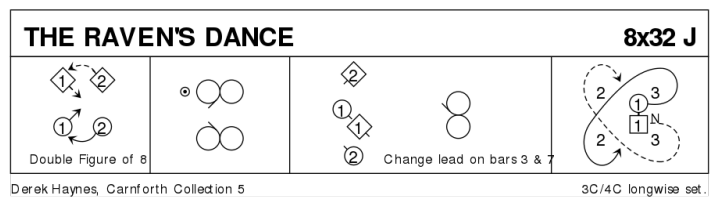

2 CROM ALLT R32 · 3/4L

Roy Goldring: A Third Book of Graded Scottish Country Dances · Crib: SCDDDB Contributed Cribs & Diagrams · Diagram: Keith Rose's Diagrams

- 1- 8 1C mirror reels of 3 on own sides (in and down to start)
- 9-16 1C and 2C turn on sides 1½ times (Men RH and Ladies LH); 1C dance between 3C and cast up to 2nd place on own sides
- 17-24 1C and 1st corners Adv & Ret; 1C and 1st corners turn RH
- 25-32 1C and 2nd corners Adv & Ret; 1C and 2nd corners turn LH

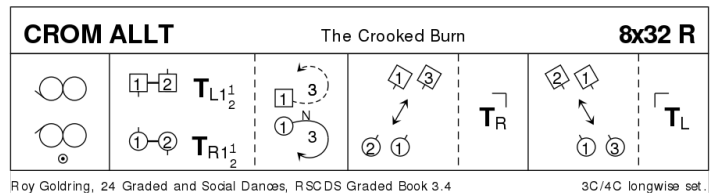

3 CHERRYBANK GARDENS S32 · 3/3L

John Drewry: Bankhead Book Part 1 · Crib: E-cribs · Diagram: Keith Rose's Diagrams

- 1- 1c+2c set | petronella in tandem ; repeat (2x,1x,3)
- 9- 2c+1c set | 2c cross RH **while{2}** 1c cross LH ; 1W+2c & 1M+3c RHA (Teapots) to sidelines (2,1,3)
- 17- 1c+3c S&Link ; 3c+1c circle4 left, end 3c facing 1c for
- 25- G-Chain (2c cross to start) (2, 3, 1)

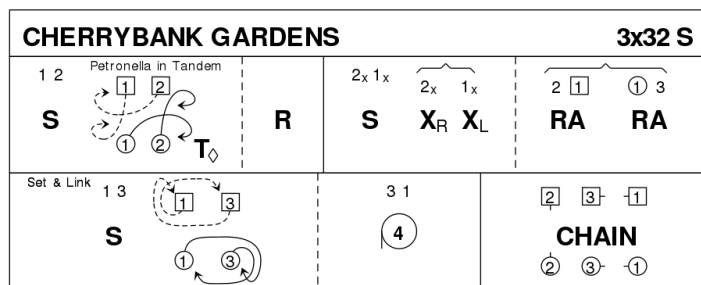

John Drewry, 1991, Bankhead 1

3C/3C longwise set.

4 THE CRANBERRY TART J32 · 3/4L

Terry Glasspool: Dances from the Seven Year Itch · Crib: E-cribs · Diagram: Keith Rose's Diagrams

- 1-16 *Fugue*: 1M set | cast (2M up) ; set | petronella to between 3c ;; set with 3c | advance with 3c ; retire with 3c | advance alone **while{16}** 1W waits {2} and then repeats 1M's [1-14], dancing with 2W and 2c, on [16] 1W pivots R to give Rsh to 2W
- 17- 1W with 1M following Reel3 across with 2c, finish (2,1,3)
- 25- Parallel Reels3 on own sides, 1c Rsh to 3c (2,1,3)

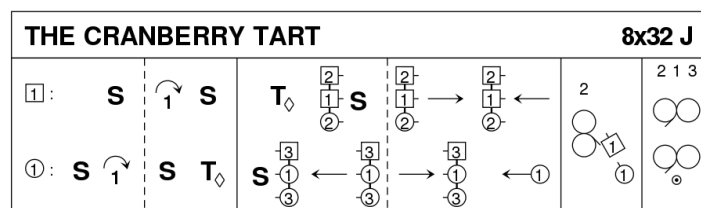

Terry Glasspool, 7 Year Itch

3C/4C longwise set.

5 JOHN OF BON ACCORD R32 · 3/4L

Roy Goldring: RSCDS XXXIII 5 · Crib: E-cribs · Diagram: Keith Rose's Diagrams

- 1-16 4 progressive ½Reels3 across, as follows: 1c+2W (1c start Rsh) ; 1c+2M (start Lsh) ; 1c+3W (Rsh) ; 1c+3M (Lsh), 1c finish in 3pl a bit in from the sidelines (2c & 3c finish their reels in 1plx and 2plx)
- 17- 1c turn RH, cast up one place on own sides (3c down) ; 1c ½ Fig8 round 2c (2x,1x,3x)
- 25- All turn P ¾ RH to face P along the midline | All Set retaining RHJ ; all turn P ¾ RH (to 2,1,3) | All Set.

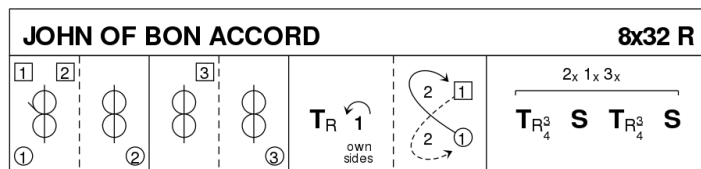

Roy Goldring, RSCDS Book 33.5

3C/4C longwise set.

6 THE DREAM CATCHER S96 · 4S

Eileen Orr: RSCDS XLV 9 · Crib: E-cribs · Diagram: Keith Rose's Diagrams

Part 1

- 1– All Circle8 and back
- 9– The Swirl: 1c+3c turn RH into Allemande hold facing in | dance Lsh round other C half way ; 1c+3c LHA, on [16] let go and swivel L to face side couples, BtoB with P, 1c below 3c
- 17– Parallel Rsh Reels4 across, finish as at start
- 25– All set | 1M+3W & 3M+1W NHJ dance out between side couple, cross and cast to own places, change place with P RH

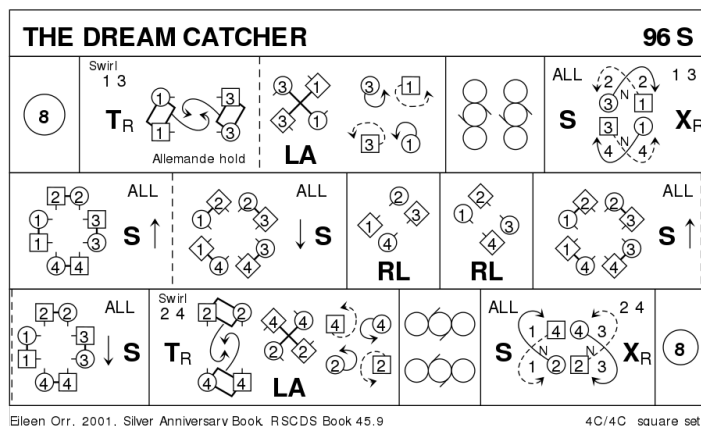

Part 2

- 1– All set | advance to middle and form circle ; retire with cnr | set
- 9– 1W+4M & 3W+2M R&L, starting across the set
- 17– 1M+2W & 3M+4W R&L, starting across the set
- 25– All set | advance to middle and form circle ; retire with P | set

Part 3

- 1-24 2c+4c starting, repeat part 1, 9-32 in the other orientation (The Swirl, Reels4 up/dn, return to places)
- 25– All Circle8 and back

7 TWIZELL BRIDGE J32 · 3/4L

Roy Goldring: Twizell Bridge + The King Over The Water [leaflet] · Crib: E-cribs · Diagram: Keith Rose's Diagrams

- 1– 1c cross RH | cast (2c up) to join RH and LH with 1cnr ; BiL | turn 1cnr LH to (2,1x,3)
- 9– 1c cross RH | cast R round 3cnr to join RH and LH with 2cnr ; BiL | turn 2cnr LH to 1M between 2c facing 1W between 3c
- 17– 1c set advancing & swiveling R (M faces up, W down) | continue as in DT_r (set ; change places | set)
- 25– Reels3{6} on opposite side (Lsh to 1cnr) | 1c cross RH (2,1,3)

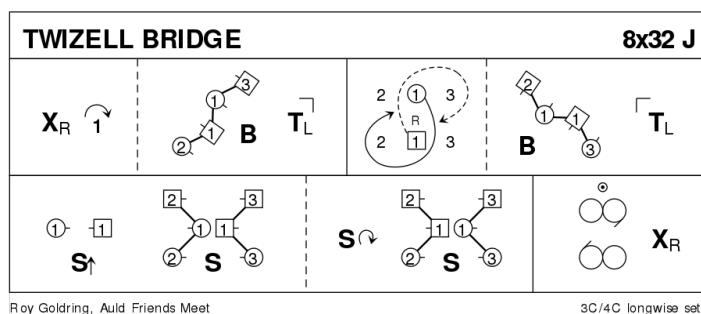

8 THE COUNTESS OF DUNMORE'S REEL R32 · 3/4L

Deirdre MacCuish Bark: RSCDS XLIX 12 · Crib: E-cribs · Diagram: Keith Rose's Diagrams

- 1-- 1c set | dance down (2c up) ; cast up round 3c | set advancing to face 1cnr
- 9-- 1c turn 1cnrs RH, pass Rsh; turn 2cnrs RH, pass Rsh to face out in 2pl (cnrs dance for {4})
- 17-- [3C Chain Progression] 1c cast ¼ clw round set **while** 2c & 3c Turn RH ¾ | 2M+3W turn LH 1½ **while{4}** the others promenade clw ½ round set | 3c+2c turn RH ¾ **while** 1c dance clw to 2pl
- 25-- all chase ½ way clw ; set - cross RH

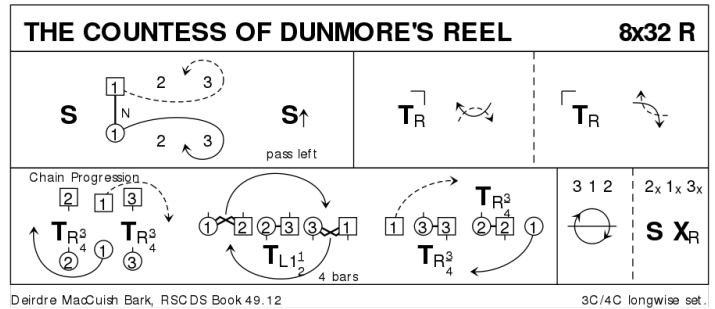

3C Chain Progression was earlier known as Chaperoned Chain Progression

9 PROGRAMME ITEM – Supper

10 THE HAZEL TREE J32 · 3/4L

John Drewry: New Dances by John Drewry 2005 · Crib: E-cribs · Diagram: Keith Rose's Diagrams

- 1-- 1c+2c Espagnole, 1c finishing facing 1cnr
- 9-- 1c turn 1cnr RH, pass Rsh ; turn 3cnr LH, pass Lsh (cnrs dance for {4})
- 17-- Turn 2cnr RH, pass Rsh ; turn 4cnr LH, pass Lsh to 2plx side by side facing down
- 25-- Lead LHJ between 3c, cross and cast to 2pl ; All C turn RH

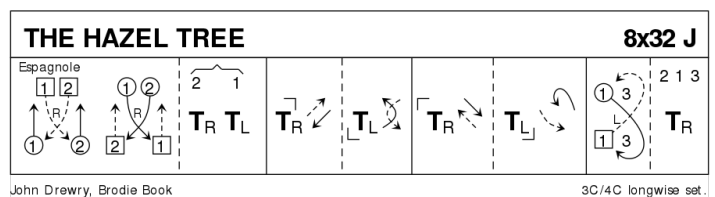

Espagnole: both W lead RHJ to M side, cross and cast back to exchanged places while{} Men cross to W side, lead RHJ back to M side and cross to exchanged places ; all turn P EH (2,1)

11 TRIP TO TIMBER RIDGE R32 · 3/4L

Linda Henderson: RSCDS LII 12 · Crib: E-cribs · Diagram: Keith Rose's Diagrams

- 1-- 1c turn RH | cast (2c up) ; 1W+2c & 1M+3c RHA, 1c facing 1cnrs at end
- 9-- Corners Pass and Turn, on [16] 1c pull Rsh back to finish BtoB in centre facing opposite side
- 17-- DTr, on [23-24] 1c Petronella turn to 2pl (2,1,3)
- 25-- Circle6 and back

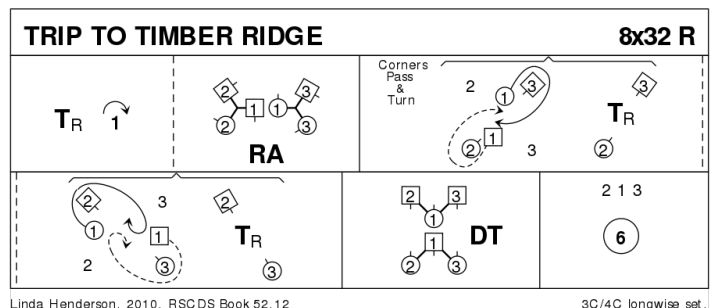

12 MISS CATHERINE ANN S32 · 3/3L

David G Queen: Queen Collection of SCD Vol 1 · Crib: MiniCribs · Diagram: Keith Rose's Diagrams

- 1-8** 1L+2L Set+Link **while** 1M+2M
Reverse Set+Link, 1s dance 1/2 Fig of 8 round 2s
- 9-16** 1M+3L Set+Link **while** 1L+3M
Reverse Set+Link, 1s dance 1/2 Fig of 8 round 3s
- 17-24** 2s+3s+1s petronella turn into centre & set to partners, 1/2 turn 2H & petronella turn back to sides for...
- 25-32** 2s+3s+1s circle 6H round & back

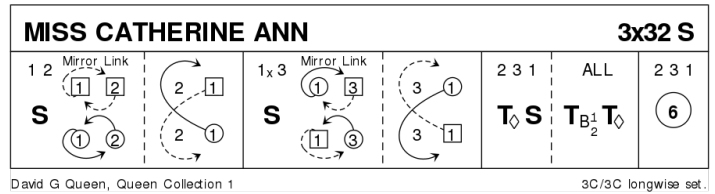

13 THE SCALLYWAG J40 · 3/4L

Jennifer Kelly: RSCDS LII 5 · Crib: E-cribs · Diagram: Keith Rose's Diagrams

- 1--** 1c long cast (2c up) ; turn LH to face 1cnr
- 9--** 1c set to 1cnr | Turn 1cnr RH $\frac{3}{4}$ into lines across and face 4cnr ; $\frac{1}{2}$ Lsh Reel3 across into facing lines across
- 17--** Lines A&R ; 1c dance Rsh round P to face 3cnr (pos)
- 25--** repeat [9-16] with these corners, finishing 1M between 2c facing 1W between 3c
- 33--** 1c set adv and join RH | set RHJ, 1W turning under the arms and 1c face up RHJ still on opp. side ; 1c cross up and cast to 2pl (2,1,3)

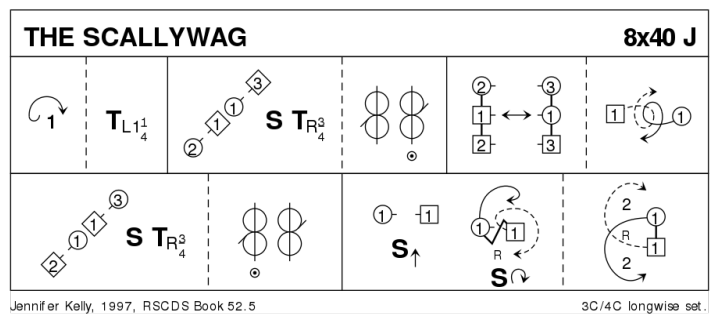

14 STAIRCASE IN STYRIA R40 · 5/5L

Margaret Gray: CD booklet of The Sunday Class Dance Book 2 · Crib: E-cribs · Diagram: Keith Rose's Diagrams

- 1--** 1c+2M & 3c+4M RHA $1\frac{1}{4}$, 1c & 3c finishing in middle facing down, other cpls in own place ; 1c+2W & 3c+4W LHA, finish facing down
- 9--** 1c+4M & 3c+5M RHA same way ; 1c+4W & 3c+5W LHA, 1W & 3W face out on own side with P behind
- 17--** 1c & 3c (W leading) cast up 1 place, cross, cast up on M side to original places the W looping R
- 25--** 1c cross | cast 1 (2c up) ; 1c followed by 3c dance up & cast to (2,3,1x,4,5)
- 33--** 1c cross | cast 1 (4c up) ; 1c followed by 5c dance up & cast to (2,3,4,5,1)

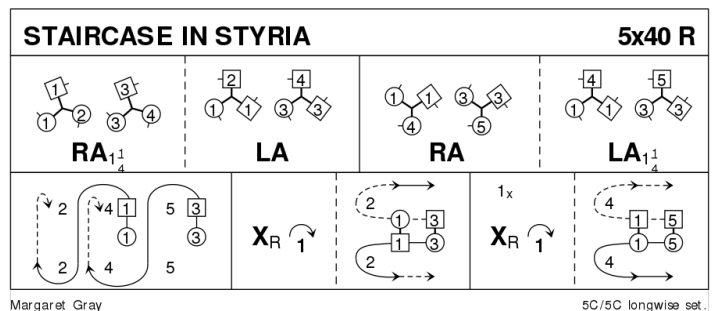

15 ANNA HOLDEN'S STRATHSPEY

S32 · 2/4L

John Drewry: RSCDS XLII 2 · Crib: E-cribs · Diagram: Keith Rose's Diagrams

- 1- 1c+2c RHA (2c face out) ; 1c cross down, **while**{2} 2c cast up | 1M+2W & 2M+1W Turn ¾ easy hand to line4 across facing down (1c between 2c)
- 9- All dance down, on [12] 1c turns in and 2c meets, all NHJ ; 1c+2c dance up | 1c cast off to 2plx, **while**{2} 2c dance to 1pl (loop is usual)
- 17- All set | »petronella in tandem« ; repeat (to 1,2x)
- 25- All set | ½ Circle4 Left ; 1c turn BH 1½ to 2pl.

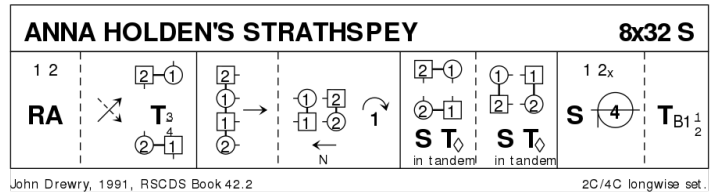

16 THE FIRST RAIN OF SPRING

J32 · 3/3L

Wouter Joubert: RSCDS XLIX 4 · Crib: E-cribs · Diagram: Keith Rose's Diagrams

- 1-- 1c dance down below 3c | cast up 1 place ; dance up to 1pl facing out | 1c+2c ½ turn EH, 2c face out
- 9-- 2c+1c DbIFig8, 1c crossing up
- 17-20 1c+3c turn P RH ¾ and face P up/dn | set ;
- 21-28 (½ Celtic Reel) 1c+3c pass Rsh | "outers" chase ¼ way clw **while**{2} "inners" turn (no hands) ¾ Lsh to face same person ; repeat
- 29-32 1c+3c Turn P RH ¾ | all set

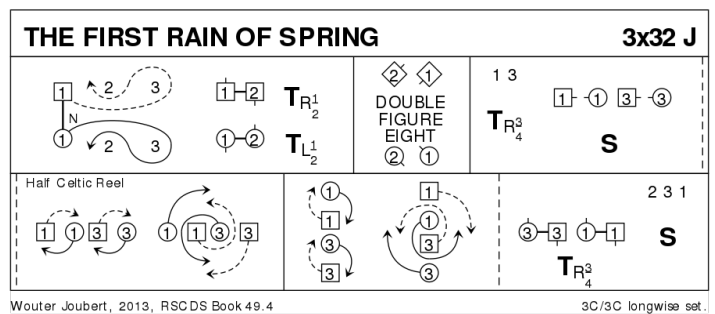

17 THE REEL OF THE ROYAL SCOTS

R32 · 3/4L

Roy Goldring: The Leaflet Dances with Music · Crib: E-cribs · Diagram: Keith Rose's Diagrams

- 1- 1W+2W (1M+2M) turn LH (RH) ½, finishing 1c BtoB in 2pl | All set as in DTr ; 1W+3W (1M+3M) turn RH (LH) ½ | 2c+3c+1c set as in DTr
- 9- 1c followed by 3c dance up between 2c, cast off ; dance NHJ down through 3pl, cast up to face 1cnrs, 3c looping into 3pl
- 17- 1c turn 1cnrs RH, pass Rsh (cnrs dance for {4}) ; turn 2cnrs RH (same), and cross Rsh to (2,1,3)
- 25- All circle6 and back

