

Leeds Branch Dance 15th June 2019

Holy Trinity Community Hall Meanwood

1 GOOD HEARTED GLASGOW J32 · 3/4L

Peter Knapman: Collins Pocket Reference: Scottish Country Dancing · Crib: E-cribs · Diagram: Keith Rose's Diagrams

- 1-- 1c turn RH | cast off (2c up) ; turn LH $1\frac{1}{4}$
- 9-- Teapots R ; and L (2c+1W & 1M+3c RHA ; 2c+1M & 1W+3c LHA)
- 17-- 1c lead down the middle and up into 2pl
- 25-- All circle6 and back



2 ORPINGTON CALEDONIANS R32 · 3/4L

John Brenchley: RSCDS XLIX 2 · Crib: E-cribs · Diagram: Keith Rose's Diagrams

- 1-- 1c set | 1W followed by 1M cast off 1pl (2c up on 5-6) and cross | 1c+3c turn LH $\frac{1}{2}$ on sidelines (1M+3M face out)
- 9-- 1c+3c L-Chain (1M face out)
- 17-- 1M followed by 1W cast up (3c down on 19-20) and cross ; 1c+2c RHA (1M+2W face out)
- 25-- Reels3 on the sides, 1c Lsh to 3c (2,1,3)

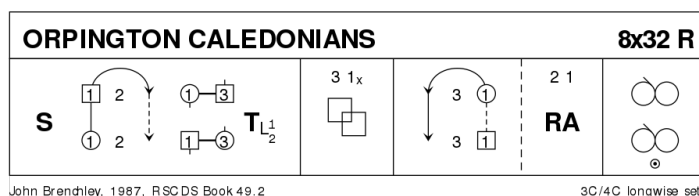

3 CASTLE DOUGLAS S32 · 3/4L

Roy Goldring: 22 Social Dances by Roy Goldring with Music · Crib: E-cribs · Diagram: Keith Rose's Diagrams

- 1-- 1c long cast (2c up on 3-4) to NHJ in centre facing 2W ; set to 2W veering L | set to 2M, finish facing M side
- 9-- 2c+1W RHA and 1M+3c LHA, 1c twirl on singly $\frac{3}{4}$ to face P up/down ; 1c set, turn $\frac{3}{4}$ BH and open out to NHJ (W on right) facing 3M
- 17-- Set to 3M | set to 3W, finish facing W side ; 2c+1M LHA and 1W+3c RHA, twirl on $\frac{3}{4}$ as before to face P on midline
- 25-- 1c set | petronella to 2pl own side ; All turn BH (2,1,3)

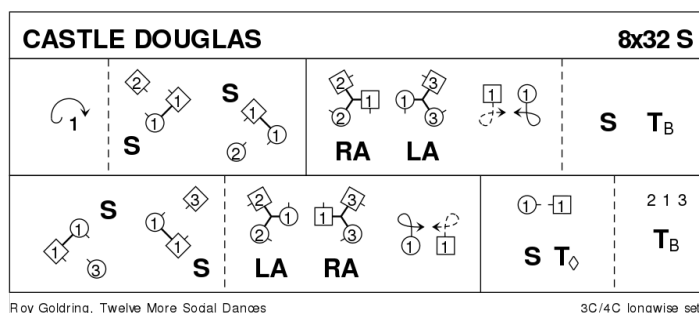

4 WELCOME TO AYR J32 · 3/4L

Jill Hendricksen/Kathy Stewart: RSCDS XLVII 8 · Crib: E-cribs · Diagram: Keith Rose's Diagrams

- 1- 1c+2c DbIFig8, 1c crossing down to start, at end 2c face out
- 9- 1c+2c turn EH 1¼ on side (2c to 1pl) and 1c face down NHJ ; 1c dance down and turn 3c EH, 3c finish in 3pl and 1c facing 1cnr
- 17- 1c+1cnrs ½ diag. Reel4 and pass Rsh ; repeat with 2cnrs, 1c finish on midline Lsh to Lsh facing own side
- 25- 3c+1M & 1W+2c RHA (3x,1x,2x) ; All chase clw ½ round (2,1,3)

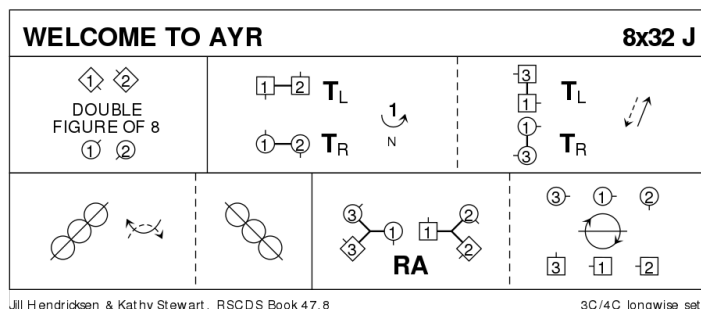

5 THE MORRISON MEASURE R32 · 5/5L

Roy Goldring: A Reel for Alice and Other Social Dances · Crib: E-cribs · Diagram: Keith Rose's Diagrams

- 1- 1c+2c+3c Rsh Reels3 on the sides, 1W finishes facing out
- 9- 1W, 1M following, casts off 2 and crosses (2c+3c up) ; 3c+1c RHA, 1W faces out (2,3,1x,4,5)
- 17- 1c+4c+5c Lsh Reels3 on the sides, 1W finishes facing out
- 25- 1W, 1M following, casts off 2 and crosses (4c+5c up) ; 5c+1c LHA (2,3,4,5,1)

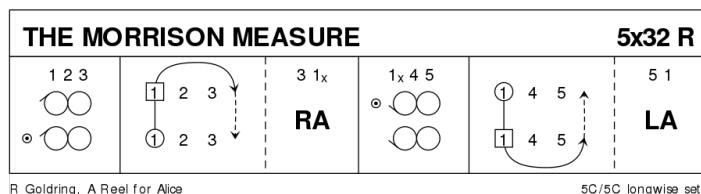

6 THE GLENGARRY HOMESTEAD S32 · 4/4L

John Brenchley: The Kangaroo Paw · Crib: E-cribs · Diagram: Keith Rose's Diagrams

- 1-- 1c ½ Fig8 with 2c **while{4}** 3c ½ Fig8 with 4c ; 1c&3c dance down one and turn inwards to face up NHJ **while{4}** 2c&4c dance up one on sidelines, turn inwards to face down NHJ | All set
- 9-- 2c+1c & 4c+3c Circle4 to L ; ½ Reels4 on sidelines, on [16] 1c+4c turn LH ¾ to finish in line across, W in centre, ready for
- 17-- 1c+4c [The Targe:] W turn RH ¾ as M chase cclw ¼ onto midline | W+M turn LH ; repeat [17-20] to finish on sidelines (3x,1,4x,2)
- 25-- ½ Reels4 on sidelines ; All set | 4c&3c cross RH (2,4,1,3)

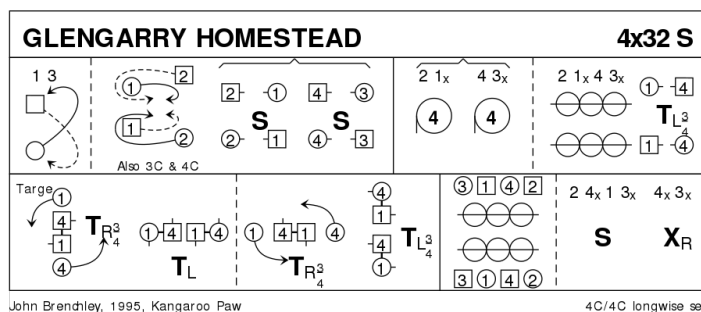

7 LIQUID ASSETS J32 · 3/4L

John Drewry: Stoneywood Collection Volume 2 · Crib: E-cribs · Diagram: Keith Rose's Diagrams

- 1-- 1c cross down into Mirror Reels3 on opposite side (1x,2,3), 2c facing out
 9-- 1c turn 2c on sideline EH 1½ (2,1x,3) ; 1c+3c repeat (2,3,1x), 3c facing out
 17-- 1c cross up into Mirror Reels3 on own side (2,3,1), 3c facing out
 25-- 1c turn 3c on sideline EH 1½ (2,1,3) ; 1c dance up between 2c and cast off to (2,1,3)

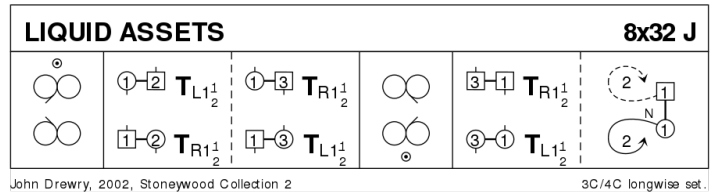

8 DANCING IN THE STREET R32 · 4/4L

Tom Toriyama: RSCDS XLII 4 · Crib: E-cribs · Diagram: Keith Rose's Diagrams

- 1-- 1c+3c turn P RH ¾ | ½ Reel4 on midline | turn P RH ¾ (3,2,1,4)
 9-- 3c+2c & 1c+4c RHA ; LHA, stay facing cclw
 17-- All chase cclw half round the set into ; Half Circle8 R, finish for
 25-- 3c+2c & 1c+4c Poussette (2,3,4,1)

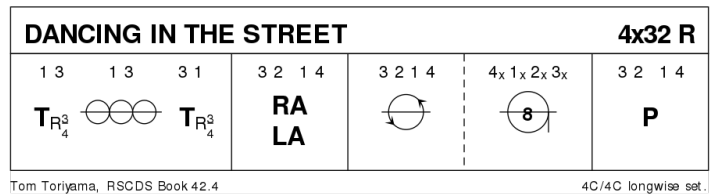

Interval

9 MACDONALD OF KEPPOCH M128 · 4S

Chris Ronald: RSCDS XLIX 11 · Crib: E-cribs · Diagram: Keith Rose's Diagrams

- 1-- 1c+3c 6 bars of R&L to BtoB facing sides | all set
 9-- Parallel Reels4 across, 1c+3c finish half way the last left pass, in a line up and down the set
 17-- 1c+3c Lsh Reel4, 1W+3W pass Rsh in middle to start, to finish in original places
 25-- All set to P | all turn P RH 1¼ | all in promhold chase cclw ¼ cclw (2,3,4,1)

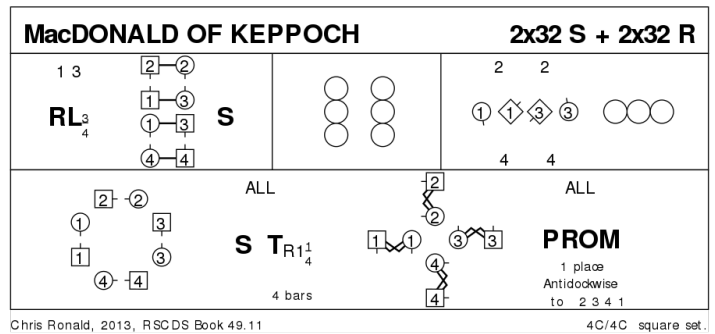

The first two turns are in Strathspey time, the second two are in Reel time.

10 THE AVIATOR J32 · 3/4L

Carola Fischer: RSCDS LII 9 · Crib: E-cribs · Diagram: Keith Rose's Diagrams

- 1-- 1c lead down (2c up), on [4] 1W crosses in front and, 1M following, casts up (round any standing M), to finish 1c in 2pl facing 3W
- 9-- 3W+1c+2M Rsh lead-change diag. Reel3 ; 1M dancing the full reel, **while for [13-16]** 1W turns 3M LH to finish behind 1M, both on midline facing up
- 17-- 2W+1c+3M Rsh lead-change diag. Reel3 ; 1W dancing the full reel, **while for [21-24]** 1M turns 3W LH to finish 1c in 2plx, 1W facing out
- 25-- 1c dance up (1W Rsh to 2M, 1M Rsh to 2W) | 1c dance Rsh round 2W to 2pl | All set.

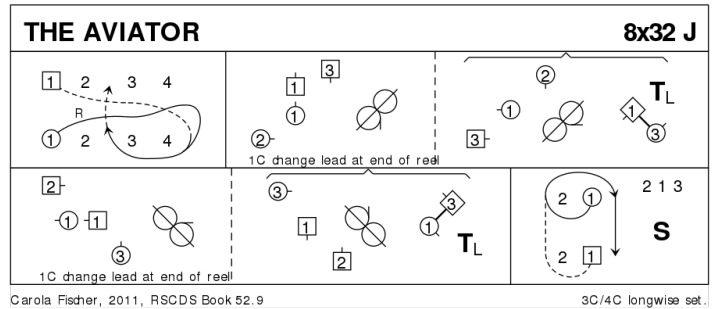

11 FINDLATER CASTLE R32 · 3/4L

Bill Forbes: Jubilee Book 1929-2004 [Banffshire] · Crib: E-cribs · Diagram: Keith Rose's Diagrams

- 1-- 1c cross down RH (2c up) into | BiL with 1cnr + 2cnr ; turn 1cnr RH | turn partner LH to 2pl own side facing out (2,1,3)
- 9-- Reels3 on the sides (Lsh to 4cnr), | pass P Lsh (2,1,3)
- 17-- 2c+1W & 1M+3c RHA ; All chase clw ½ (3x,1x,2x)
- 25-- All S&Link3 twice (2,1,3)

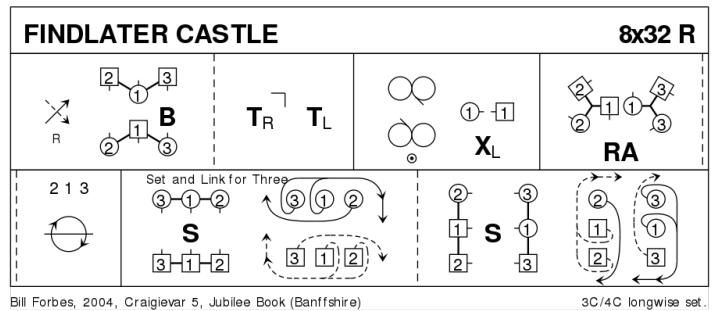

12 FAIR DONALD S32 · 3/4L

RSCDS XXIX 4 · Crib: E-cribs · Diagram: Keith Rose's Diagrams

- 1-- 1c dance NHJ between 2c and cast up to top ; dance NHJ between 3c and cast up to 1cnrs (2c up on [7-8])
- 9-- Reel4 with 1cnrs, at the end pass Lsh to face 2cnrs
- 17-- Reel4 with 2cnrs, finishing between 2c on own side, facing up NHJ
- 25-- 1c cast off one | 2c+1c+3c set ; all turn P BH

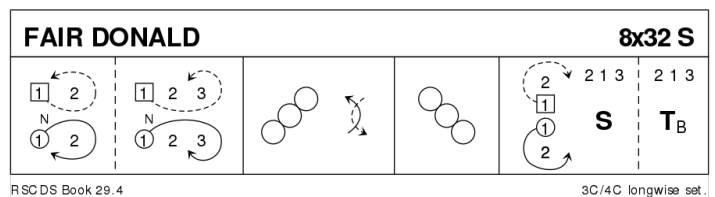

13 THE WANDERING WALLABY

J32 · 4/4L

Peter Fish: RSCDS 50 7 · Crib: E-cribs · Diagram: Keith Rose's Diagrams

- 1-- All Circle8 & back
- 9-- Reels4 on the sides
- 17-- 1c followed by 2c+3c+4c cast off behind own lines ; meet and dance up to finish in the middle
- 25-- 1c retain hands and set twice | cast off to 4th place **while{8}** 2c+3c+4c Promenade, and finish in (2,3,4,1)

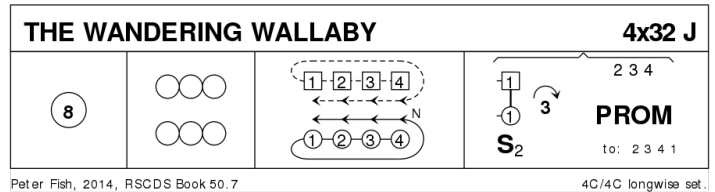

14 THE GLENALMOND GAMEKEEPER

R40 · 3/4L

John Drewry: Bankhead Book Part 6 · Crib: E-cribs · Diagram: Keith Rose's Diagrams

- 1-- Crossover Reels3 on the sides, 1c crosses down, to (1x,2,3) with 1c +3c slightly in from sidelines
- 9-- 1c+3c L-Chain, down/up, at end M with P behind face out (1x,2,3)
- 17-- 1c+3c, M leading, cast R into each a full Fig8 round 2c, passing Lsh first time, Rsh second time ("hug your turning post"), into
- 25-- Circle6 and back (to 1x, 2, 3)
- 33-- 1c+2c set | ¼ DbIFig8, (2c cross up to start)

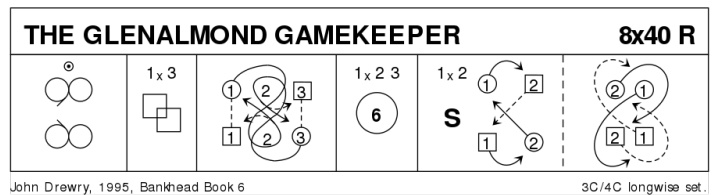

(1c continues into the new reel, on second turn 1c casts to 4pl and 3c (in 2pl) dances on into the new reel)

15 INDIAN RIVER STRATHSPEY

S32 · 3T

George Senyk: Scottish Country Dances in Diagrams. Ed. 9 · Crib: E-cribs · Diagram: Keith Rose's Diagrams

- 1-- All in promhold Reel3 across (1c & 3c Rsh to begin).
- 9-- With 1W leading, 1c+3c RHA ; 1c+2c LHA
- 17-- 2c+3c L-Chain **while{}** 1c set | dance down the middle & cast up round the outside to orig. place.
- 25-- 1c+3c ½R&L ; 1c+2c ½R&L. (to 3,1,2)

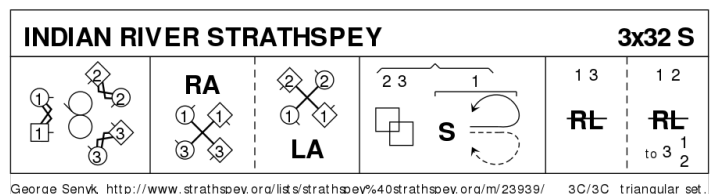

16 FOLLOW ME HOME J32 · 3/4L

Ellie Briscoe: RSCDS XXXVIII 3 · Crib: E-cribs · Diagram: Keith Rose's Diagrams

- 1- 1c set | cross RH ; cast off (2c up) | turn $\frac{3}{4}$ LH
- 9- BiL with 1cnrs | $\frac{1}{2}$ turn 1cnrs RH ; 1c followed by 1cnrs chase clw round 4cnrs to leave 1cnrs in exchanged places, and join LH to 2cnr, RH to P
- 17- BiL with 2cnrs | $\frac{1}{2}$ turn 2cnrs LH ; 1c followed by 2cnrs chase cclw, 1c crossing Lsh to 2plx facing out (3x,1x,2x)
- 25- $\frac{1}{2}$ Lsh Reels3 on the sidelines ; All set and cross (2,1,3)

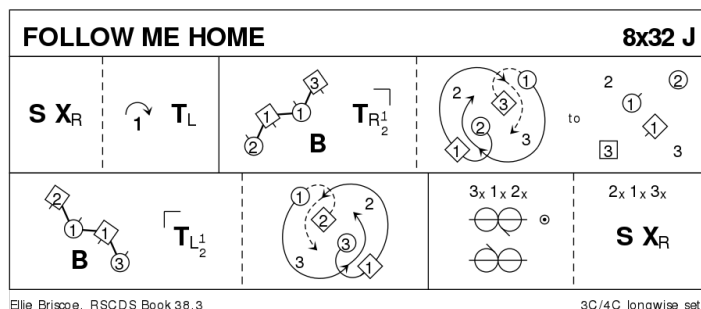

Extras

17 ST ANDREW'S FAIR J32 · 3/4L

Roy Goldring: Five Scottish Country Dances 1982 · Crib: E-cribs · Diagram: Keith Rose's Diagrams

- 1- 1c cross RH | cast off 2 (2c up) ; cross LH and cast up (2,1,3)
- 9- All turn RH $\frac{1}{2}$ | retain hold & set ; all chase clw to own sides (3,1,2)
- 17- 3c+1c+2c Circle6 and back
- 25- All turn LH $\frac{1}{2}$ | retain hold & set ; all chase cclw to (2,1,3)

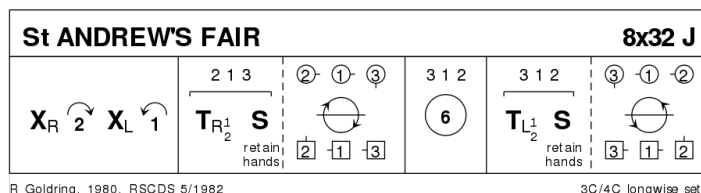

note: 3c does not move on bars 1-8.

18 THE COLLEGE HORNPIPE R32 · 3/4L

W Boag (18C): RSCDS XX 12 · Crib: E-cribs · Diagram: Keith Rose's Diagrams

- 1- 1c+2c+3c circle6 and back, finishing in couples for
- 9- 1c+2c+3c Promenade
- 17- 1c cross RH, cast off one {3} cross LH, cast off one | lead up to face 1cnrs (2c up on [19-20])
- 25- 1c SetH&G with clap on [31] and Petronella Turn to own sideline

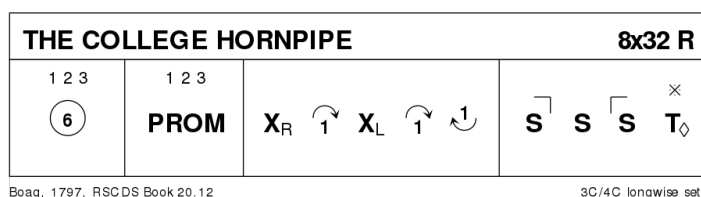

19 THE MINISTER ON THE LOCH S32 · 3/3L

Roy Goldring: Magazine Dances 2005-2009 · Crib: E-cribs · Diagram: Keith Rose's Diagrams

- 1- 1c+2c Poussette
- 9- 1c dance down 2 places, turn BH ;
dance up 2 places, turn BH, open
upwards and face out
- 17- 1c+3c DbIFig8 round 2c, 1c casting, 3c
crossing up to begin, 1c finish facing
out for
- 25- 1W+2W & 1M+2M turn EH 1½ ; 1c+3c repeat (2,3,1)

