

# Leeds Branch Dance 17th March 2018

## 1 LIQUID ASSETS J32 · 3/4L

John Drewry: *Stoneywood Collection Volume 2* · Crib: *Eric's E-cribs* · Diagram: *Keith Rose's Diagrams*

- 1-- 1c cross down into Mirror Reels3 on opposite side (1x,2,3), 2c facing out  
 9-- 1c turn 2c on sideline EH 1½ (2,1x,3) ; 1c+3c repeat (2,3,1x), 3c facing out  
 17-- 1c cross up into Mirror Reels3 on own side (2,3,1), 3c facing out  
 25-- 1c turn 3c on sideline EH 1½ (2,1,3) ; 1c dance up between 2c and cast off to (2,1,3)

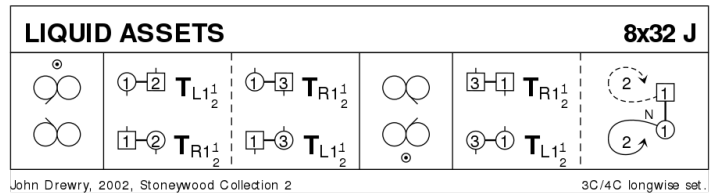

## 2 THE SPRING FLING REEL R40 · 3/4L

Samantha Burton: *RSCDS L 1* · Crib: *Eric's E-cribs* · Diagram: *Keith Rose's Diagrams*

- 1-- 1c turn RH | cast off (2c up) ; cross RH and cast R into lines across (1W+2c face 1M+3c)  
 9-- All A&R up/down , Circle ½ L into lines across  
 17-- All A&R up/down ; 1c turn RH 1¼ to face 1cnr  
 25-- 1c+1cnrs ½ diag Reel4 1c pass Rsh ; repeat with 2cnrs, finish 1M below 1W  
 33-- 2c+1W & 1M+3c LHA ; 2c+3c turn LH as 1c turn RH 1½ (2,1,3)

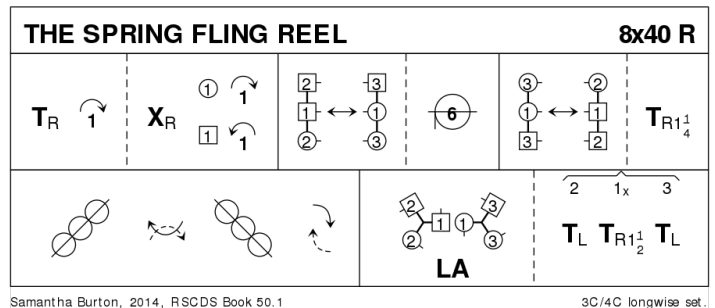

## 3 THE SILVER TASSIE S32 · 3/4L

John Drewry: *The Leaflet Dances with Music* · Crib: *Eric's E-cribs* · Diagram: *Keith Rose's Diagrams*

- 1- 1c+2c+3c cross RH | set ; repeat  
 9- 1c+3c DbIFig8 round 2c (1c cross down, 3c cast up)  
 17- 1c followed by 2c+3c dance down the middle (2c & 3c divide) ; 1c (leading) +2c+3c dance up  
 25- 1c+2c Rondel (2,1,3).

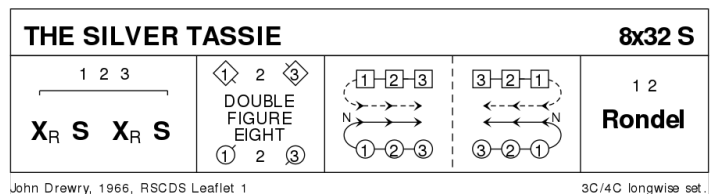

## 4 THE WEATHERCOCK J32 · 4/4L

Veronica Hughes: *A Second Book of Graded Scottish Country Dances* · Crib: *Eric's E-cribs* · Diagram: *Keith Rose's Diagrams*

- 1- Parallel Reels<sup>4</sup> on the sides  
 9- 1c+3c set advancing to midline and join RH with P, LH in middle | BiL (2c+4c up) ; 1c+2c & 3c+4c RHA  
 17- 1W+3M turn LH  $\frac{3}{4}$  while } 1M+3W dance round clw  $\frac{1}{4}$  to meet P in line across | BiL ; repeat  
 25- 3c+2c & 1c+4c RHA ; 1c+3c turn person ahead (»corner«) RH to finish (2,3,4,1) (M turn once and a bit, W turn  $1\frac{1}{2}$  and a bit)

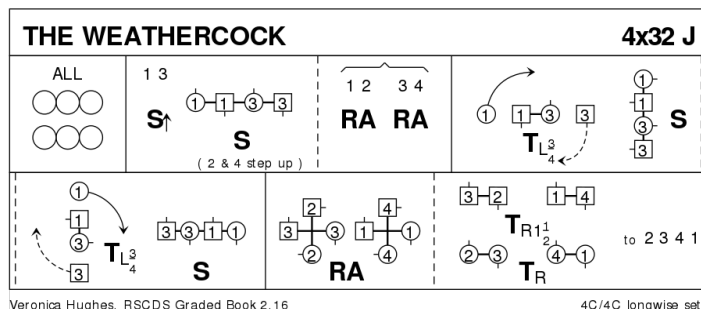

note: the set tends to move upwards; ease down gently in the turns to end in the right positions

## 5 THE INIMITABLE DEREK R32 · 3/4L

Roy Goldring: *Magazine Dances 2005-2009* · Crib: *Eric's E-cribs* · Diagram: *Keith Rose's Diagrams*

- 1- 1W+2W & 1M+2M turn  $1\frac{1}{4}$  EH, 1c starting inwards, into line across with 1c BtB in the middle | 1c+2c set ; turn with the other hand  $\frac{3}{4}$  (1c starts up) to (2,1,3), 2c facing out  
 9- Opposing Reels<sup>3</sup> on the sides, 1c start to the R (1M Rsh to 3M, 1W Rsh to 2W), on [13-14] 1c cross to »2cnr position, on [15-16] 1c turn 2cnr persons (2W and 3M) RH into 2diagonal line  
 17- 1c+2cnrs BiL | 1c turn LH to join 1cnr with RH ; BiL | 1c turn LH to finish side by side in the centre, 1W facing up, 1M down  
 25- 1W+2W+3W & 1M+2M+3M RHA ; 1M+1W dance out the end and cast R into (2,1,3)

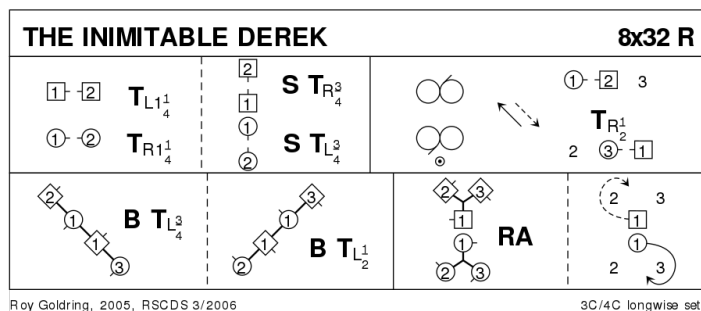

## 6 DANCE: A COUPLE OF KEEPERS (REFER TO SEPARATE INSTRUCTIONS, COPYRIGHT)

## 7 JOHN CASS J32 · 5/5L

Peter Avery: *RSCDS XLIX 10* · Crib: *Eric's E-cribs* · Diagram: *Keith Rose's Diagrams*

- 1-- 1c lead down (2c+3c up) ; lead up to 3pl and turn RH to face out on M side giving Rsh to 3M, 1W behind 1M  
 9-- 2M+3M & 1c & 4W+5W diag. Reel<sup>3</sup>, all cpls lead-change at both ends, 1c finish giving Lsh to 4M, 1W behind 1M  
 17-- 2W+3W & 1c & 4M+5M diag. Reel<sup>3</sup>, all cpls lead-change at both ends, 1c finish in 3pl facing down NHJ  
 25-- 1c dance between 4c, cast behind 5c (4c+5c up) ; 1c pivot turn with R elbow grip (2,3,4,5,1)

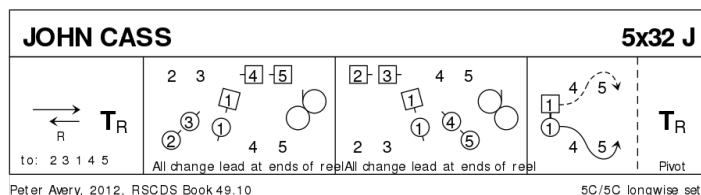

## 8 PEGGY'S STRATHSPEY S32 · 3/4L

Eric Finley: RSCDS XLI 5 · Crib: Eric's E-cribs · Diagram: Keith Rose's Diagrams

- 1- 1c cross down RH **while**{2} 2c cast up and 3c set | Mirror Reels3{6} on sidelines, 1c starting out and down (to 2,1x,3)
- 9- 3c cross up LH **while**{2} 1c cast off & 2c set | Mirror Reels3{6} on sidelines, 3c starting out and up (to 2,3x,1x)
- 17- 3c+1c ½ R&L ; 2c+1c ½ R&L (to 1x,2x,3)
- 25- 1c+2c Reversed Espagnole :[1M+2M lead RHJ to M side crossing 2M in front and cast back to exchanged places **while**{ } 1W+2W cross to W side, cast in and lead RHJ to M side crossing 2W in front, to exchanged places ; both C turn P EH 1½] (to 2,1,3)

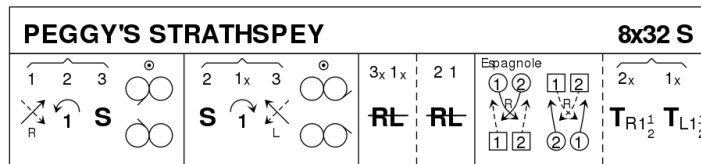

Eric Finley, RSCDS Book 41.5

3C/4C longwise set.

For [16] Finley's original version says »... third couple ... in 2nd place on the opposite side, "having danced the long way into place", a phrase omitted in the RSCDS version.

## 9 CRAIGLEITH R88 · 4S

Roy Goldring: A Third Book of Graded Scottish Country Dances · Crib: Eric's E-cribs · Diagram: Keith Rose's Diagrams

- 1- 1c+3c R&L
- 9- 1c+3c L-Chain
- 17- 2c+4c R&L
- 25- 2c+4c L-Chain
- 33- All W A&R, RHA, finish facing out
- 41- All W Chase clw round set (cast behind P to begin)
- 49- All M A&R, LHA, , finish facing out
- 57- All M Chase cclw round set (cast behind P to begin)
- 65- 1c+3c Promenade cclw round inside of set to own place, set facing in
- 73- 2c+4c Promenade clw round inside of set to own place, set facing in
- 80- All circle8 and back

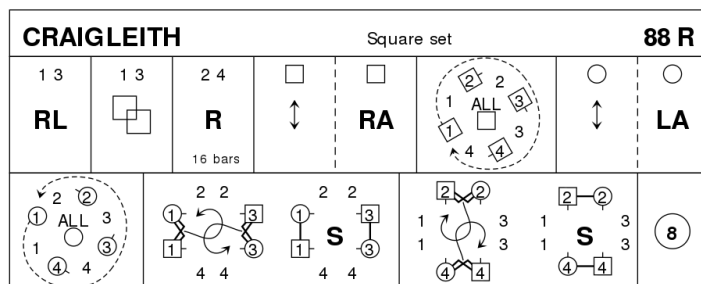

Roy Goldring, Graded and Sodal Dances 2, RSCDS Graded Book 3.6

4C/4C square set.

## 10 INTERVAL

## 11 GAELFORCE WIND J32 · 3/4L

Derek Haynes: A Third Book of Graded Scottish Country Dances · Crib: Eric's E-cribs · Diagram: Keith Rose's Diagrams

- 1- 1c set and cross RH, 1c+2c S&Link, 2W+1W finish facing out. (2,1x,3)
- 9- 2c+1c M-Chain.
- 17- 1c ½ Fig8 L (Rsh to 4cnr) ; All turn RH (2,1,3)
- 25- All Circle6 and back (2,1,3)

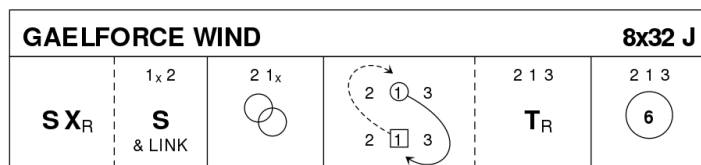

Derek Haynes, 1996, Carnforth Collection 3, RSCDS Graded Book 3.12

3C/4C longwise set.

## 12 THE CASTLE OF MEY R32 · 3/4L

John Walton: QE Diamond Jubilee Dances · Crib: Eric's E-cribs · Diagram: Keith Rose's Diagrams

- 1- Inveran Reels 3 on the sides, 1c crossing down to start (1,2,3)
- 9- 1c+2c DblFig8, 1c cross down to start
- 17- 1c lead down the middle and up, finishing for
- 25- 1c+2c Poussette

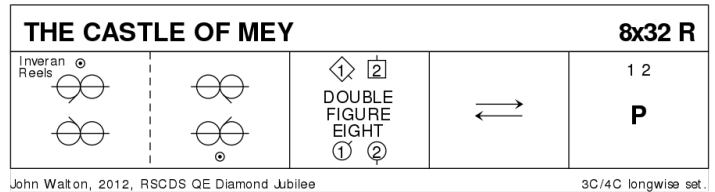

## 13 SANDY'S SCOTCH BROTH S32 · 3/3L

Gail Sibley: Katannuta, a Collection of Salt Spring Island Scottish Country Dances · Crib: Eric's E-cribs · Diagram: Keith Rose's Diagrams

- 1- All Circle 6 and back
- 9- 1c NHJ dance down | set ; dance up | cast to 2pl (2c up) facing 1c nr
- 17- 1c+1cnrs pass and turn ; 1c+2cnrs repeat, finish 1c facing out (2,1,3)
- 25- Chaperoned Chain progression (2c+3c turn RH 3/4 to midline **while**{2} 1c cast R 1/4 round set | 2M+3W turn LH 1 1/2 **while**{4} 1M+2W & 3M+1W in promhold dance 1/2 round set clw | 1c dance clw to 2pl **while**{2} 3c+2c turn RH 3/4) (3,1,2)

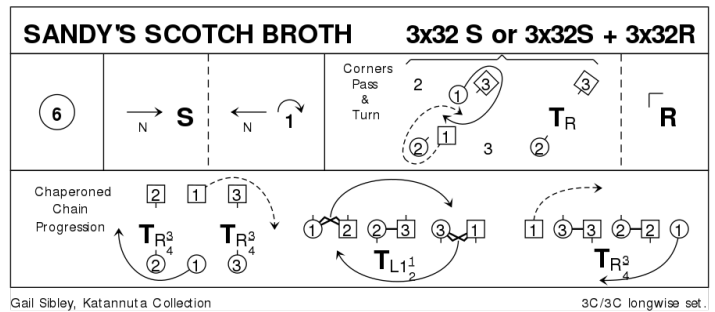

## 14 THE IMMIGRANT LASS J32 · 4/4L

Morton Jay: RSCDS XXXIX 5 · Crib: Eric's E-cribs · Diagram: Keith Rose's Diagrams

- 1- 1c+2c turn RH 1 1/2 ; 1c+2c RHA **while** {3c+4c turn RH 1 1/2}
- 9- 1c+2c 1/2 R&L **while** {3c+4c RHA ; 1c+3c 1/2 R&L (2,3,1x,4x)}
- 17- 3c+1c L-Chain
- 25- 1c+4c lead up {3}, change sides (M loop above **while** {W under M's arm}) ; lead down | 4c casts up **while** {1c dances straight into 4pl (2,3,4,1)}

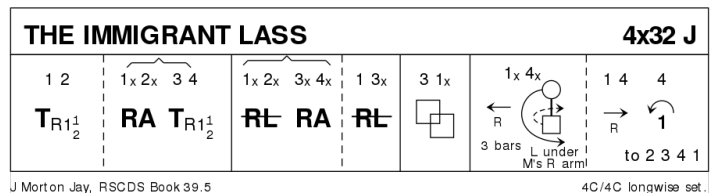

## 15 CROM ALLT R32 · 3/4L

Roy Goldring: A Third Book of Graded Scottish Country Dances · Crib: SCDDDB Contributed Cribs & Diagrams · Diagram: Keith Rose's Diagrams

- 1-8 1C mirror reels of 3 on own sides (in and down to start)
- 9-16 1C and 2C turn on sides 1 1/2 times (Men RH and Ladies LH); 1C dance between 3C and cast up to 2nd place on own sides
- 17-24 1C and 1st corners Adv & Ret; 1C and 1st corners turn RH
- 25-32 1C and 2nd corners Adv & Ret; 1C and 2nd corners turn LH

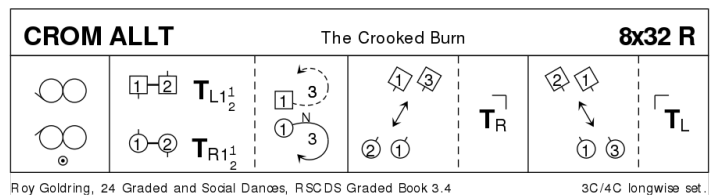

## 16 MIDSUMMER COMMON S32 · 3/4L

Tom & Lindsey Ibbotson: RSCDS XLIX 3 · Crib: SCDDDB Contributed Cribbs & Diagrams · Diagram: Keith Rose's Diagrams

- 1-- 1c set | ½ turn RH ; lead down, cross below 3c (2c up on [5-6] and cast to 2pl (2,1,3)
- 9-- 1c set adv to into BtoB facing 1cr while 1cr set | turn 1cnr BH into lines across ; 1c set adv to into BtoB facing 2cr while 2cr set | turn 2cnr BH
- 17-- 1W+3c & 1M+2c circle3, at end 1c swivels R to face P ; 1c set | 1c Petronella turn (to 2,1,3)
- 25-- 1c+2c poussette

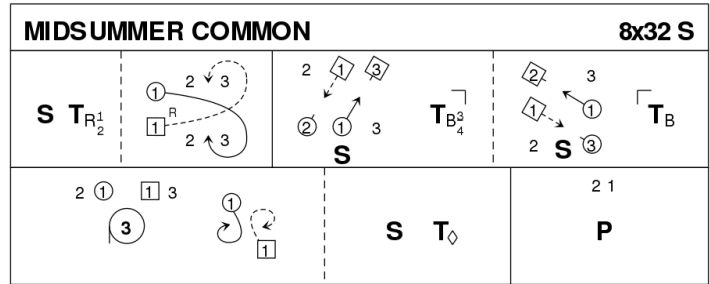

Tom and Lindsey Ibbotson, 2013, RSCDS Book 49.3

3C/4C longwise set.

## 17 NEIL M GRANT J32 · 3/4L

Christine Grant: RSCDS XLIX 1 · Crib: Eric's E-cribs · Diagram: Keith Rose's Diagrams

- 1-- 1c cross RH | cast off (2c up) ; ½ Fig8 R (round 3cnr) to join with P LH and 1cnrs RH
- 9-- The Spoke: BiL{1}, advance LHJ cclw to next cnr {1} | repeat 3 times, finish facing 1cnr
- 17-- 1c+1cnrs ½ diag Reel4, pass Rsh ; 1c+2cnrs ½ Diag Reel4 (3x,1x,2x)
- 25-- all chase clw half round ; teapots R (2,1,3)

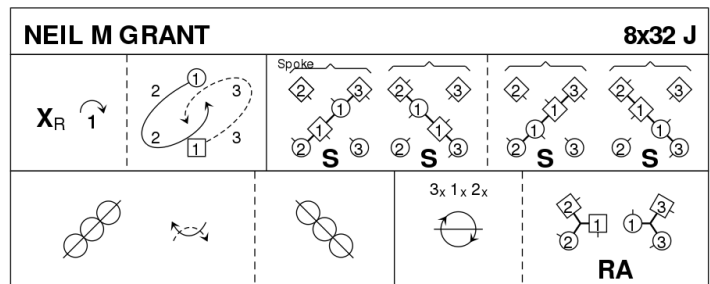

Christine Grant, 2012, RSCDS Book 49.1

3C/4C longwise set.

## 18 THE ROBERTSON RANT S80 · 4S

Mrs Douglas Winchester: RSCDS XXXIX 8 · Crib: Eric's E-cribs · Diagram: Keith Rose's Diagrams

- 1-- All Circle8 and back
- 9-- Double L chain (women ½ RHA, turn opposite M LH ; ½ RHA, turn P LH, to own places)
- 17-- 1c+3c Reel4, (W pass left shoulder, M set on [17-18], at the end W slow down and M speed up, face and acknowledge P and pull back inner shoulder to face corners.
- 25-- All set to corner H.Schottische ; turn cnr BH twice
- 33-48 2c+4c repeat [17-32]
- 49-- Women Circle4 L (at end pull back Rsh to face out) ; set to and turn P BH.
- 57-- Men circle4 R, pull back Lsh ; set to and turn P BH.
- 65-- G-Chain (one step per hand)
- 73-- Promenade cclw round the set in Allemande hold, M bring W into middle of set and hold RH for bow and curtesy

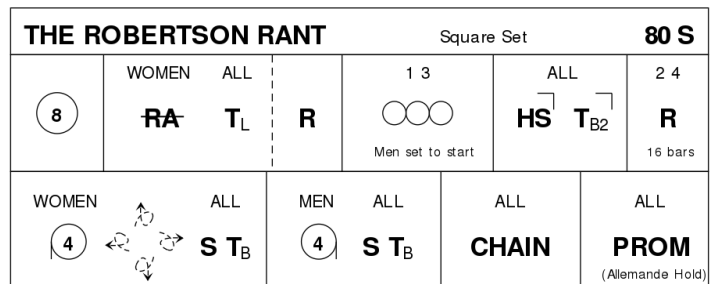

Mrs Douglas Winchester, 1949, RSCDS Book 39.8

4C/4C square set.

## 19 THE DEIL AMANG THE TAILORS R32 · 3/4L

RSCDS XIV 7 · Crib: Eric's E-cribs · Diagram: Keith Rose's Diagrams

- 1- 1c+2c set, ½ RHA ; set, ½ LHA
- 9- 1c lead down the middle and up, 2c step in for
- 17- 1c+2c Allemande
- 25- 2c+1c+3c circle6 and back.

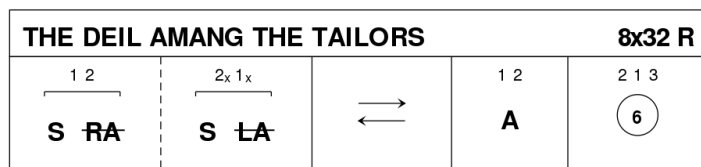

Davies Collection, RSCDS Book 14.7

3C/4C longwise set.

## 20 EXTRAS

## 21 THE MINISTER ON THE LOCH S32 · 3/3L

Roy Goldring: Magazine Dances 2005-2009 · Crib: Eric's E-cribs · Diagram: Keith Rose's Diagrams

- 1- 1c+2c Pousette
- 9- 1c dance down 2 places, turn BH ; dance up 2 places, turn BH, open upwards and face out
- 17- 1c+3c DbIFig8 round 2c, 1c casting, 3c crossing up to begin, 1c finish facing out for
- 25- 1W+2W & 1M+2M turn EH 1½ ; 1c+3c repeat (2,3,1)

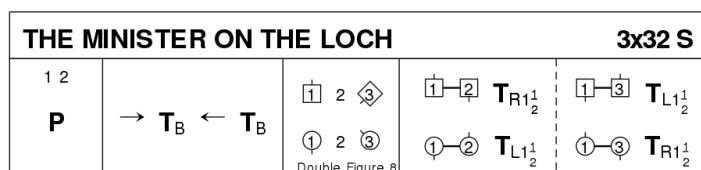

Roy Goldring, 24 Graded & Social Dances, RSCDS 4/2008

3C/3C longwise set.

## 22 THE JUBILEE JIG J32 · 3/4L

RSCDS: The Leaflet Dances with Music · Crib: Eric's E-cribs · Diagram: Keith Rose's Diagrams

- 1- 1M casts off one (2M up) | 1M+3W set (not advancing) ; turn RH to own side
- 9- 1W casts off one (2W up) | 1W+3M set ; turn LH (to 2,1,3)
- 17- 2c+1W & 1M+3c RHA, 1c finish in centre LHJ, facing opposite sides ; 1c set | dance out to opposite side (2,1x,3)
- 25- 1M+2c & 1W+3c RHA, 1c finish in centre LHJ facing own sides ; 1c set | dance out (2,1,3).

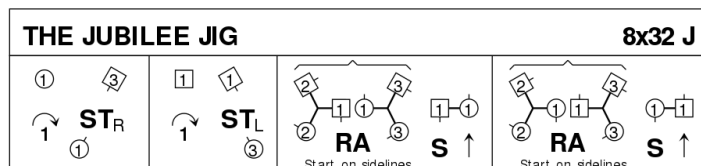

1973, RSCDS Leaflet 19

3C/4C longwise set.