

Leeds Branch Dance 19th May 2018

1 WELCOME TO AYR J32 · 3/4L

Jill Hendricksen/Kathy Stewart: RSCDS XLVII 8 · Crib: E-cribs · Diagram: Keith Rose's Diagrams

- 1- 1c+2c DbIFig8, 1c crossing down to start, at end 2c face out
- 9- 1c+2c turn EH 1¼ on side (2c to 1pl) and 1c face down NHJ ; 1c dance down and turn 3c EH, 3c finish in 3pl and 1c facing 1cnr
- 17- 1c+1cnrs ½ diag. Reel4 and pass Rsh ; repeat with 2cnrs, 1c finish on midline Lsh to Lsh facing own side
- 25- 3c+1M & 1W+2c RHA (3x,1x,2x) ; All chase clw ½ round (2,1,3)

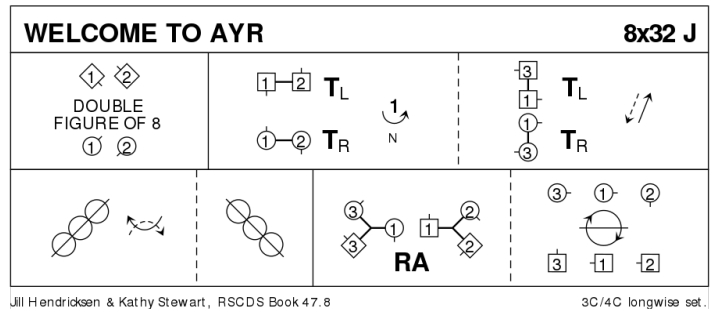

2 MAXWELL'S RANT R32 · 3/4L

David Rutherford: RSCDS XVIII 10 · Crib: E-cribs · Diagram: Keith Rose's Diagrams

- 1- Mirror Reels3 on the sidelines (1c cross down) (1x,2,3)
- 9- 1c cross back into mirror Reels3 on own sides
- 17- 1c cross RH | cast (2c up) ; ½ Fig8 round 2c
- 25- 1c dance down between 3c and cast up to 2pl ; 2c+1c+3c turn RH

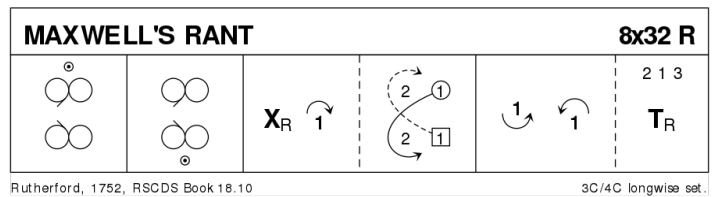

3 THE SILVER CITY S32 · 3/4L

John Drewry: Silver City Book of SCD · Crib: MiniCribs · Diagram: Keith Rose's Diagrams

- 1-8 1s cross down to dance reflection reels of 3 on opposite sides
- 9-16 1s in prom hold dance reel of 3 across with 2s giving RSh to 2M, 2s dance into 1st place as 1s turn LH to face 1st corners
- 17-24 1s turn 1st corner RH, turn partner LH, turn 2nd corner RH, 1/2 turn partner LH to end 1L facing 2s & 1M facing 3s
- 25-32 1s dance RH across (Lady with 2s & Man with 3s), pass RSh & dance LH across with other couple

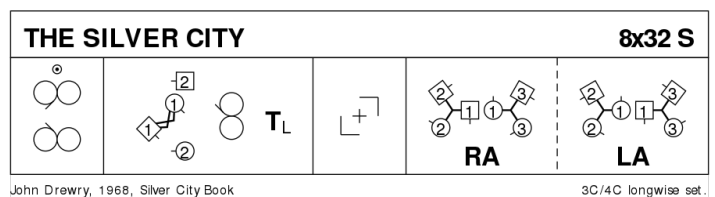

4 JIM'S HABERDASHERY J40 · 3/4L

Alan Macpherson: Bannockburn 700 · Crib: E-cribs · Diagram: Keith Rose's Diagrams

- 1-- 1c+2c DbIFig8, 2c begins out and up
 9-- 1c+2c turn EH 1½ on sidelines ; cast off behind 3c and cross up to (2,1x,3)
 17-- Mirror Reels3 on the sides, 1c starts out and up , At the end 1c cross to (2,1,3)
 25-- Mirror Reels3 on the sides, 1c starts out and up , At the end 1c face up NHJ between 3c
 33-- 1c dance to top, cast off ; All turn P RH (2,1,3)

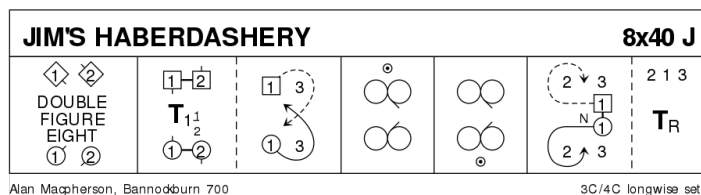

The deviser prefers his original [33-40]: 1c dance up and turn 2c EH (2,1,3) ; 1c turn 3c other hand (2,1,3)

5 THE BLACK BEAR R32 · 3/4L

Ian Galbraith: Berkhamsted Strathspey and Reel Club Golden Jubilee 1952-2002 · Crib: E-cribs · Diagram: Keith Rose's Diagrams

- 1-- 1c+2c set | ½ RHA ; Set, 2c cross LH and 1c turn LH to face 1c
 9-- SetH&G , finish facing 3c
 17-- ½Reel4 on 1diag, pass Rsh to face 4c ; ½Reel4 on 2diag, finish (3x,1,2x)
 25-- Diagonal ½R&L with 1cns ; repeat with 2cns

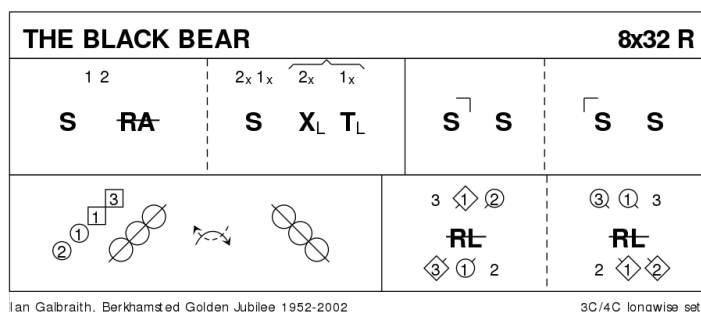

6 CITY OF BELFAST S32 · 3/3L

Lucy Mulholland: RSCDS XLVIII 6 · Crib: E-cribs · Diagram: Keith Rose's Diagrams

- 1-- 1c ½ Fig8 round 2c ; 1c turn 2c EH 1¼ into line across, 1c in the middle
 9-- 1c+2c Reel4, finish 2c in 1pl and 1c (last pass is Lsh) facing 1c
 17-- 1c set to 1cns | set to 2cns, dancing R into sideline (2,1x,3) ; All set | 1c cross RH
 25-- 1c+3c Espagnole (2,3,1)

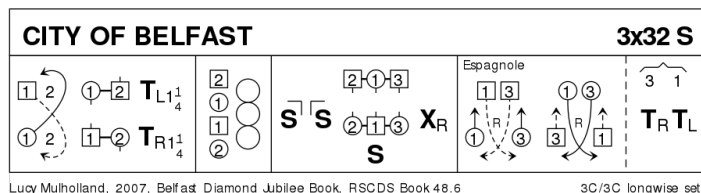

Espagnole: both W lead RHJ to M side, cross and cast back to exchanged places while Men cross to W side, lead RHJ back to M side crossing to exchanged places ; all turn P EH (2,1)

7 A FLOCK OF GEESE J32 · 5/5L

Melbourne Briscoe: *Slip Knot Collection plus 7 More* · Crib: *E-cribs* · Diagram: *Keith Rose's Diagrams*

- 1– 1c+3c+5c set advancing to line of six NHJ with P on the right | BiL ; 1c turn $\frac{3}{4}$ RH and cast to 5pl **while**{4} 3c+5c turn $\frac{3}{4}$ RH and lead up to 1pl / 3pl (3,2,5,4,1)
- 9– 3c+5c+1c repeat bars 1-8 from new places (5,2,1,4,3)
- 17– 1c followed by 5c lead down the middle ; and up to 2pl/4pl (2c+4c up) (2,5,4,1,3)
- 25– 2c+5c & 1c+3c R&L.

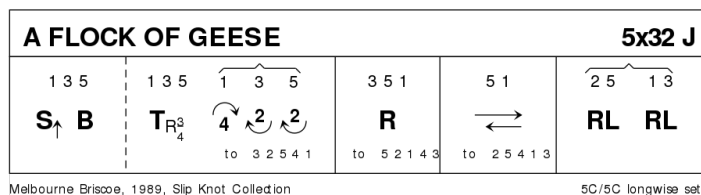

This dance is rather similar to Olivia Robert's »The Black Swans of Narrabeen«; the progression is different

8 SCOTT MEIKLE R32 · 4/4L

Alice McLean: *RSCDS XLVI 3* · Crib: *E-cribs* · Diagram: *Keith Rose's Diagrams*

- 1– 1c cross RH | cast (2c up) ; $\frac{1}{2}$ Fig8 up (2,1,3,4)
- 9– 1c+3c RHA, LHA (2,1,3,4)
- 17– Lsh opposing Reels3 across: (1W+3W behind dancing as one) with 2c and (3M+1M behind) with 4c (to 2,3,1,4)
- 25– 1c+4c $\frac{1}{2}$ R&L ; turn RH $1\frac{1}{2}$ (2,3,4,1)

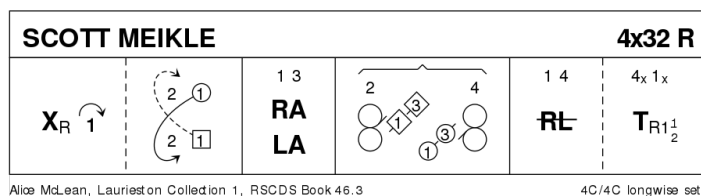

9 PROGRAMME ITEM – Interval

10 GAELFORCE WIND J32 · 3/4L

Derek Haynes: *A Third Book of Graded Scottish Country Dances* · Crib: *E-cribs* · Diagram: *Keith Rose's Diagrams*

- 1– 1c set and cross RH, 1c+2c S&Link, 2W+1W finish facing out. (2,1x,3)
- 9– 2c+1c M-Chain.
- 17– 1c $\frac{1}{2}$ Fig8 L (Rsh to 4cnr) ; All turn RH (2,1,3)
- 25– All Circle6 and back (2,1,3)

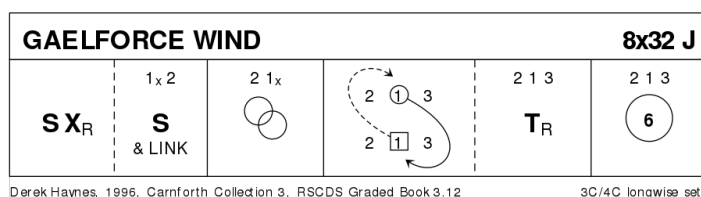

11 RAMADAN-CE R32 · 3/4L

John Drewry: *The Turkish Set* · Crib: *E-cribs* · Diagram: *Keith Rose's Diagrams*

- 1– 1c+2c+3c Inveran Reels (1,2,3)
- 9– 1c cross RH | cast (2c up) ; Turn RH to face 1cnr
- 17– 1c+1cnrs pass Rsh | cnrs turn RH $\frac{1}{2}$ and cast away as 1c meet and pass Rsh to face 2cnrs ; repeat with 2cnrs (3x,1x,2x)
- 25– $\frac{1}{2}$ Reels3 across, 1c Lsh to 3cnr ; $\frac{1}{2}$ Reels3 on the sides, 1c Rsh to 4cnr (2,1,3)

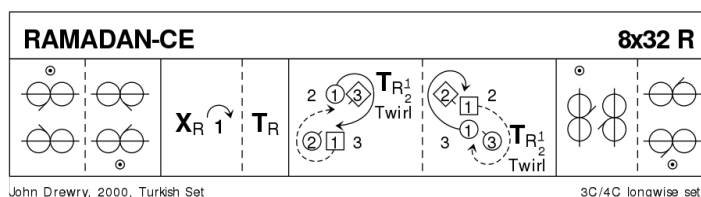

15 MISS ELEANOR S32 · 3/3L

Ann Dix: RSCDS XLIX 5 · Crib: SCDDDB Contributed Cribes & Diagrams · Diagram: Keith Rose's Diagrams

- 1-- Mirror Reels3 on the sides, 1c start in and down
- 9-- 1c set | cast off (2c up) ; turn RH to face out | cast R (2M down, 3W up)
- 17-- 3 couple Bourrel (3,1,2)
- 25-- Circle6 and back

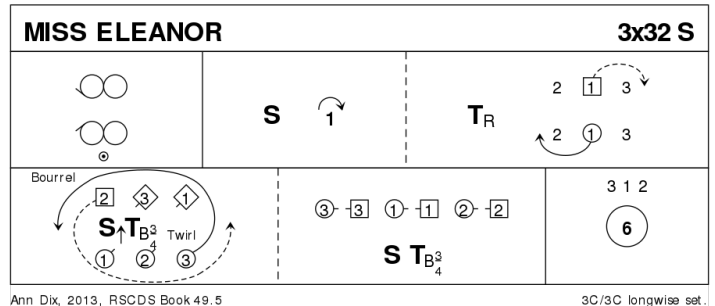

16 THE WAGGLE O' THE KILT J40 · 3/4L

James B Cosh: Twenty Two SCD · Crib: E-cribs · Diagram: Keith Rose's Diagrams

- 1-- 1c cast off, lead through 3c (2c up), cast up, turn LH
- 9-- 1M+2M+3M & 1W+2W+3W RHA (1c pass Rsh) ; 1W+2M+3M & 1M+2W+3W RHA (same hand!), 1c finish facing 1cnr
- 17-- 1c ½Reel4 with 1cnrs, pass Lsh, ½Reel4 with 2cnrs and face 3cnr
- 25-- 1c turn 3cnrs (1cnr person) RH ½, corners turn LH 1½ (or ½) ; 1c turn cnr RH ½, 1c turn LH to face 4cnr (2cnr person)
- 33-- Repeat with 2cnr persons, 1c finish the LH turn (2,1,3).

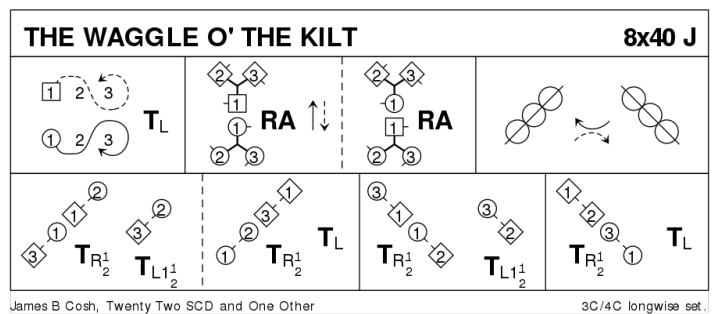

Note: on [13], the description says "change places", so 1c could also make a fast ½ LH turn into the other wheel)

17 MAIRI'S WEDDING R40 · 3/4L

James B Cosh: Twenty Two SCD · Crib: E-cribs · Diagram: Keith Rose's Diagrams

- 1-- 1c turn RH | cast (2c up) ; turn LH to face 1cnrs
- 9-- 1c ½Reel4 with 1cnrs (pass P Lsh) ; Repeat with 2cnrs
- 17-- Repeat with 3cnrs (1cnr person) ; Repeat with 4cnrs (2cnr person)
- 25-- 1W+2c & 1M+3c Reels3 across, Lsh to 1cnr
- 33-- 2c+1c+3c circle6 and back

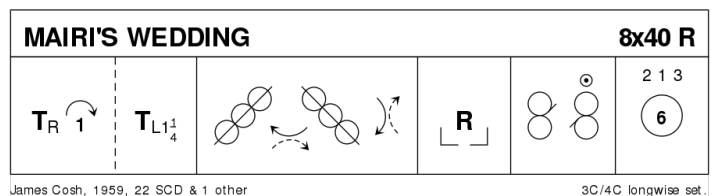

Note: Cosh explicitly tells 1c to pass Lsh in [9-24]; however the Rsh pass is quite common, and nicknamed »Mairi's Divorce«.

18 PROGRAMME ITEM – Extras

19 AIRYHALL DELIGHT J32 · 3/4L

Doris S Young: RSCDS XL 8 · Crib: E-cribs · Diagram: Keith Rose's Diagrams

- 1- 1c+2c set | ½ RHA ; 1c+3c ½ R&L (2x,3x,1)
- 9- 1c+3c set | ½ LHA ; 2c+1c ½ R&L (to 1,2,3)
- 17- 1c lead down the middle (2c up) ; lead up to 2pl | 2c+1c+3c set
- 25- All circle6 and back.

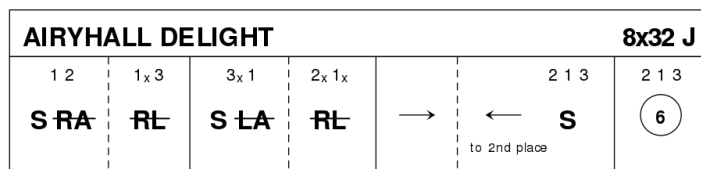

Doris S Young, RSCDS Book 40.8

3C/4C longwise set.

20 THE HIGHLAND RAMBLER R40 · 3/4L

Roy Goldring: Silver Jubilee 25 - Leeds Branch · Crib: E-cribs · Diagram: Keith Rose's Diagrams

- 1- 1c long cast to 2pl (2c up on [3-4] ; 1c+3c RHA (2,1,3)
- 9- 2c+1c LHA, 1W faces out ; 1W followed by 1M cast up round 2W and down the middle of set, 1W between 3c and 1M between 2c, all facing down
- 17- In lines of 3 down the middle (all swivel R) and up
- 25- 1M followed by 1W dance up, cast round 2W and into 2pl ; 1c turn RH
- 33- Circle6 and back

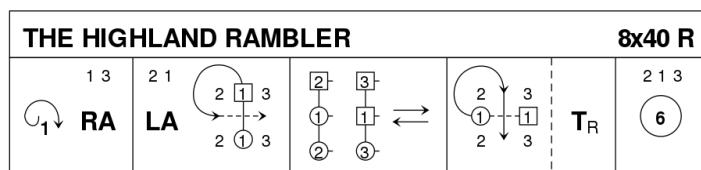

Roy Goldring, 1985, Leeds Silver Jubilee

3C/4C longwise set.

21 THE SWAN AND THE TAY S32 · 3/3L

Audrey Saunders: Scottish Country Dances for Perth 800 · Crib: E-cribs · Diagram: Keith Rose's Diagrams

- 1- 1c (in and down) Fig8 on own sides (give hands) (1,2,3)
- 9- 1c cross into Reels3{6} on opp. sides | 2c dance up as 1c face 1cnr
- 17- 1c+cnrs Pass&Turn, pass Rsh ; repeat with 2cnr, finish (2,1,3)
- 25- All set | cross RH ; chase ½ clw (3,1,2)

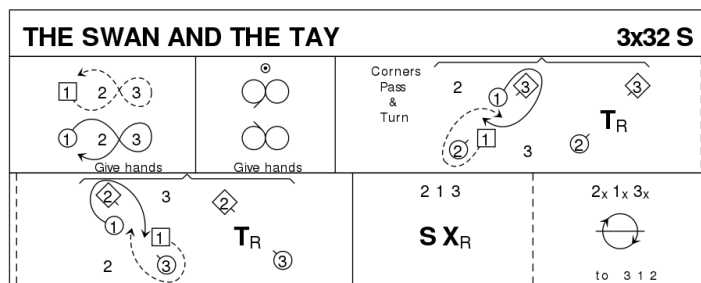

Audrey Saunders, Scottish Country Dances for Perth 800

3C/3C longwise set.