

Leeds Branch Dance 20th October 2018

1 JOIE DE VIVRE J32 · 3/4L

Irene van Maarseveen: RSCDS XXXIX 2 · Crib: E-cribs · Diagram: Keith Rose's Diagrams

- 1-- 1c set | cast (2c up) ; dance between 3c and cast up to (2,1,3)
- 9-- All turn P RH to sidelines ; all chase clw half round (to 3x,1x,2x)
- 17-- All dance BtoB ; all set | all ½ RH turn into
- 25-- 3c+1c+2c Allemande (2,1,3)

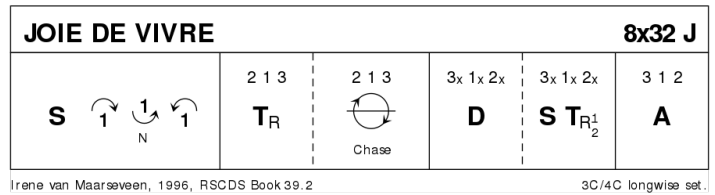

2 ORPINGTON CALEDONIANS R32 · 3/4L

John Brenchley: RSCDS XLIX 2 · Crib: SCDDDB Contributed Cribs & Diagrams · Diagram: Keith Rose's Diagrams

- 1-- 1c set | 1W followed by 1M cast off 1pl (2c up on 5-6) and cross | 1c+3c ½ turn LH on sidelines (1M+3M face out)
- 9-- 1c+3c L-Chain (1M face out)
- 17-- 1M followed by 1W cast up (3c down on 19-20) and cross ; 1c+2c RHA (1M+2W face out)
- 25-- Reels3 on the sides, 1c Lsh to 3c

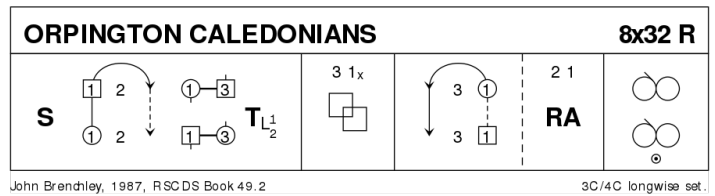

3 MARGARET PARKER'S STRATHSPEY S32 · 3/4L

John Drewry: RSCDS XXXI 3 · Crib: E-cribs · Diagram: Keith Rose's Diagrams

- 1-- 1c lead down crossing between 2c, cast off round 3c and NHJ up the middle ; 1W LHA (and 1M RHA) with 1cnr+2cnr, 1c finish in 1plx facing out (1x,2,3)
- 9-- 1c+2c change places on sides EH | 1c turn BH ¾ to finish facing down, 1M just above 2c and 1W (swivel R) just above 3c ; 1M+2c & 1W+3c Circle3 left, into lines across facing down
- 17-- Lines of 3 dance down the middle, swivel R, dance up, finish line facing line
- 25-- Lines set | cross RH ; set, 2c+3c cross back RH while{2} 1c cast to own side (2,1,3)

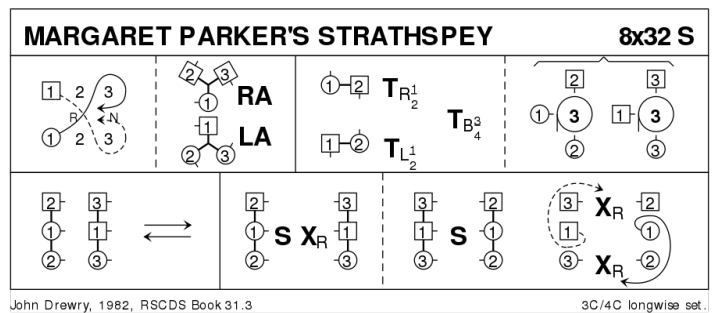

4 NAPIER'S INDEX J40 · 3/4L

Brian Charlton: RSCDS XLV 8 · Crib: E-cribs · Diagram: Keith Rose's Diagrams

- 1- 1c set | cast off ; turn LH 1¼ into
- 9- 1c+1cnrs BiL | 1c+1cncr turn RH {4} | repeat BiL
- 17- 1c+cnrs Reels3 on the sides, Lsh to 2cncr, 1c finish LHJ and RHJ with 2cncr
- 25- 1c+2cncr repeat [9-16]
- 33- Reels3 across, 1c Lsh to 3c, at end 1c cross RH as 2c+3c curve into place (2,1,3)

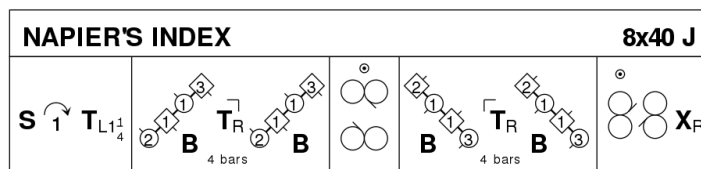

Brian Charlton, 2001, RSCDS Book 45.8

3C/4C longwise set.

5 THE WHISTLING WIND R32 · 3/4L

Elizabeth Goossen: RSCDS XXXVI 5 · Crib: E-cribs · Diagram: Keith Rose's Diagrams

- 1- 1c set | long cast to 2pl (2c up on [5-6]) | set advancing to 1cnrs
- 9- 1c ½Reel4 with 1cnrs, pass Rsh ; 1c ½Reel4 with 2cnrs finishing BtoB in the middle, 1M facing up, 1W down
- 17- DTr up / down, finish 2pl own side (3x,1,2x)
- 25- diagonal R&L (M down, W up) (2,1,3)

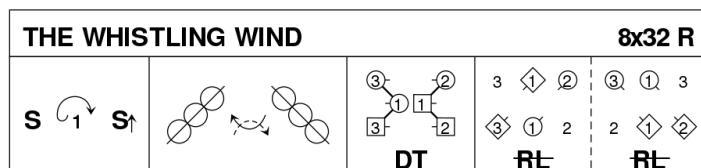

Elizabeth Goossen, 1984, RSCDS Book 36.5

3C/4C longwise set.

6 ROUGEMONT CASTLE S32 · 3/3L

Duncan Brown: RSCDS XLVIII 12 · Crib: E-cribs · Diagram: Keith Rose's Diagrams

- 1- 1c cross between 3c and cast up (2c up) ; ½Fig8 L (W up, M down) (2,1,3)
- 9- All cross RH | chase clw ¼ to lines across ; All cross up/dn RH | chase clw ¼ (3x,1x,2x)
- 17- Chain R&L (mid dancers change place RH with cnrs diagonally R | new mid dancers repeat LH with cnrs to L ; repeat to the R (2x,1x,3x) | 2c Cross RH while{2} 1c+3c turn RH ½ into
- 25- 1c+3c Allemande (2,3,1)

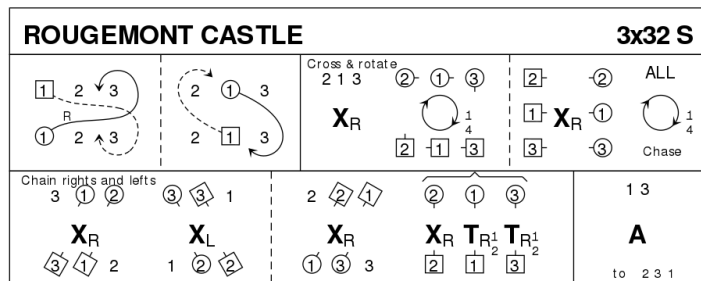

Duncan Brown, Exeter Branch 40, RSCDS Book 48.12

3C/3C longwise set.

7 GAELFORCE WIND J32 · 3/4L

Derek Haynes: A Third Book of Graded Scottish Country Dances · Crib: E-cribs · Diagram: Keith Rose's Diagrams

- 1- 1c set and cross RH, 1c+2c S&Link, 2W+1W finish facing out. (2,1x,3)
- 9- 2c+1c M-Chain.
- 17- 1c ½ Fig8 L (Rsh to 4cncr) ; All turn RH (2,1,3)
- 25- All Circle6 and back (2,1,3)

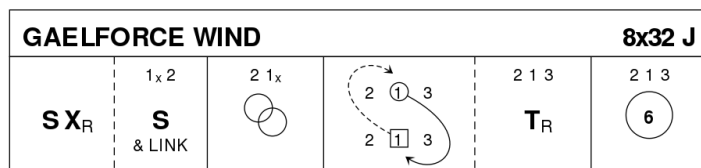

Derek Haynes, 1996, Carnforth Collection 3, RSCDS Graded Book 3.12

3C/4C longwise set.

8 MACDONALD OF KEPPOCH M128 · 4S

Chris Ronald: RSCDS XLIX 11 · Crib: SCDDDB Contributed Cribs & Diagrams · Diagram: Keith Rose's Diagrams

- 1-- 1c+3c 6 bars of R&L to BtoB facing sides | all set
- 9-- Parallel Reels4 across, 1c+3c finish half way the last left pass, in a line up and down the set
- 17-- 1c+3c Lsh Reel4, 1W+3W pass Rsh in middle to start, to finish in original places
- 25-- All set to P | all 1¼ turn P RH | all ¼ cclw chase in promhold (2,3,4,1)

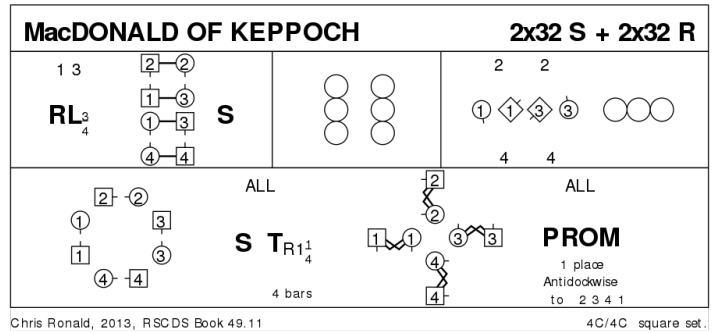

The first two turns are in Strathspey time, the second two are in Reel time.

9 PROGRAMME ITEM – Interval

10 LIQUID ASSETS J32 · 3/4L

John Drewry: Stoneywood Collection Volume 2 · Crib: E-cribs · Diagram: Keith Rose's Diagrams

- 1-- 1c cross down into Mirror Reels3 on opposite side (1x,2,3), 2c facing out
- 9-- 1c turn 2c on sideline EH 1½ (2,1x,3) ; 1c+3c repeat (2,3,1x), 3c facing out
- 17-- 1c cross up into Mirror Reels3 on own side (2,3,1), 3c facing out
- 25-- 1c turn 3c on sideline EH 1½ (2,1,3) ; 1c dance up between 2c and cast off to (2,1,3)

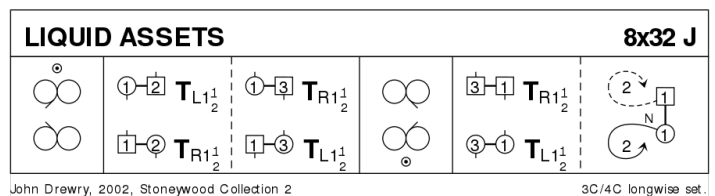

11 SUENO'S STONE R32 · 3/4L

Neil N Grant: Magazine Dances 2005-2009 · Crib: E-cribs · Diagram: Keith Rose's Diagrams

- 1– 1c turn RH | cast (2c up) ; turn LH 1½ to face 2c, LHJ with P
- 9– Set to 2c & turn inwards | set to 4c ; ½Reel4 with 4c, finish LHJ facing 1c
- 17– Set to 1c & turn inwards | set to 3c ; ½Reel4 with 3c, finish 1M above 1W on midline, facing P
- 25– 2c+3c set and chase 1 place clw while {4} 1c turn RH 1½ to join the chase ; All chase 1 place clw and set (2,1,3)

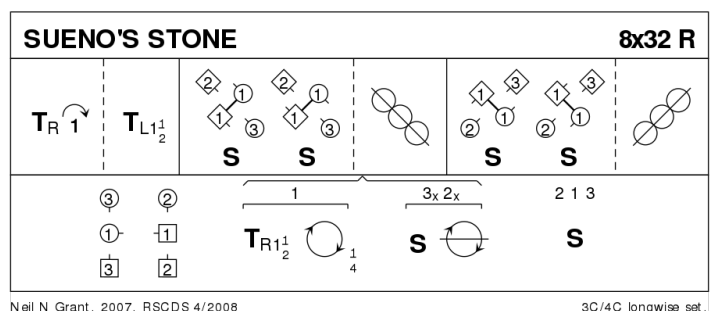

12 THE GENTLEMAN S32 · 3/4L

Roz Scott Huxley: RSCDS XXXV 5 · Crib: E-cribs · Diagram: Keith Rose's Diagrams

- 1- 2c step up as 1c turn BH to face P between them in line4 across | 1c+2c set, 1c advancing and passing on the second step ; ½Reel4, at end 1c pass LH to face down NHJ
- 9- 1c dance down to face P between 3c, repeat set and ½Reel4 with 3c, finish between 3c on own side LHJ
- 17- 1c lead to top, cross and cast to 2plx ; ½Reels3 across, Rsh to 4cnr (W up, M dn) (to 2,1,3)
- 25- 2c+1c Poussette.

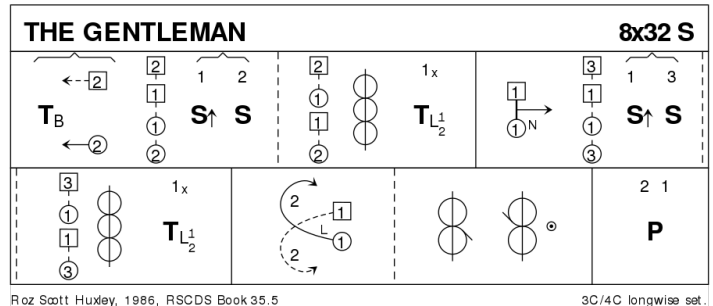

13 THE HAZEL TREE J32 · 3/4L

John Drewry: New Dances by John Drewry 2005 · Crib: E-cribs · Diagram: Keith Rose's Diagrams

- 1- 1c+2c Espagnole, 1c finishing facing 1cnr
- 9- 1c turn 1cnr RH, pass Rsh ; turn 3cnr LH, pass Lsh (cnrs dance for {4})
- 17- Turn 2cnr RH, pass Rsh ; turn 4cnr LH, pass Lsh to 2plx side by side facing down
- 25- Lead LHJ between 3c, cross and cast to 2pl ; All C turn RH

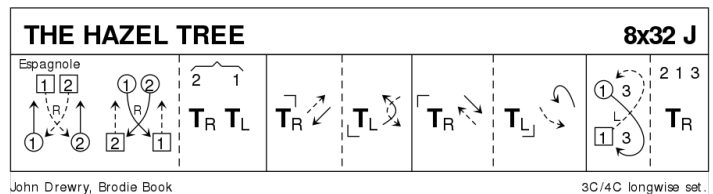

Espagnole: both W lead RHJ to M side, cross and cast back to exchanged places while{} Men cross to W side, lead RHJ back to M side and cross to exchanged places ; all turn P EH (2,1)

14 SWISS LASSIE R32 · 3/4L

Rosi Betsche: RSCDS XXXIX 1 · Crib: E-cribs · Diagram: Keith Rose's Diagrams

- 1- 1c cast off 2 (dance in to begin) (2c+3c up) ; 2c+1c 1¼ turn RH to midline, facing P
- 9- 2c+1c Reel4 on midline, 2M and 1W end facing opposite side, with P behind
- 17- 2c & 1c chase clw round 3c to (1,3,2) ; All A&R
- 25- 3c+2c turn RH ½, leading into ½ RHA, to sidelines ; 1c+2c repeat (2,1,3)

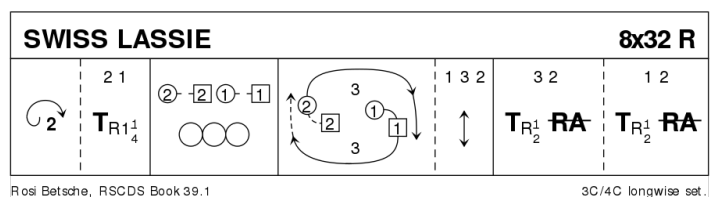

15 JEAN MARTIN OF ABERDEEN

S32 · 3/3L

Muriel A Johnstone: Magazine Dances 2005-2009 · Crib: E-cribs · Diagram: Keith Rose's Diagrams

- 1- 1c Turn RH, cast (2c up) ; All circle6 L $\frac{3}{4}$ into lines across (W facing down, M up)
- 9- All set | change places RH with P ; All circle6 L left $\frac{3}{4}$ and end in middle facing up (3,1,2) for
- 17- Allemande (2,1,3)
- 25- 1c+3c Bourrel : 1M+3W set adv. | Turn BH $\frac{3}{4}$ & twirl to end BtoB in middle, 3W facing up & 1M down **while**{4} 1W+3M chase cclw to face P set to P | Turn BH $\frac{3}{4}$ to (2,3,1)

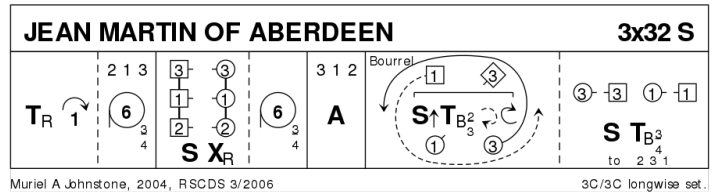

16 THE BEES OF MAGGIEKNOCKATER

J32 · 4/4L

John Drewry: The Canadian Book of Scottish Country Dances · Crib: E-cribs · Diagram: Keith Rose's Diagrams

- 1- 1c cross RH | cast off (2c up) ; 1c+3c RHA, finish as pairs 1M+3W & 3M+1W facing out on W/M side in promhold
- 9- Pairs+ 2c+4c Rsh $\frac{1}{2}$ Reels3 on sides ; pairs meet & take P in promhold for Lsh $\frac{1}{2}$ Reels3 on sides
- 17- Meet and repeat (as pairs Rsh $\frac{1}{2}$ Reels3 ; with P Lsh $\frac{1}{2}$ Reels3)
- 25- 1c (passing inside) turn 3c $1\frac{1}{2}$ Easy Hand ; 1c cross and passing inside turn 4c EH $1\frac{1}{2}$ (to 2,3,4,1)

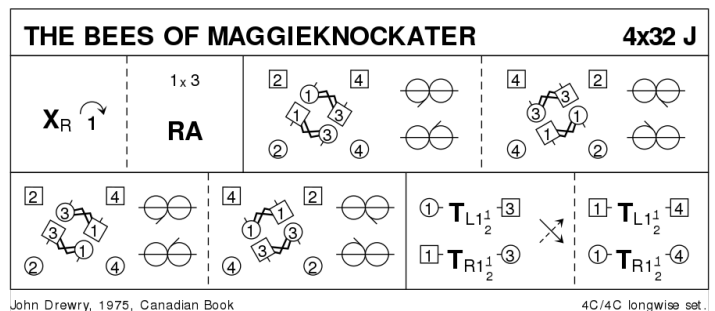

17 THE REEL OF THE ROYAL SCOTS

R32 · 3/4L

Roy Goldring: The Leaflet Dances with Music · Crib: E-cribs · Diagram: Keith Rose's Diagrams

- 1- 1W+2W (1M+2M) turn LH (RH) $\frac{1}{2}$, finishing 1c BtoB in 2pl | All set as in DTr ; 1W+3W (1M+3M) turn RH (LH) $\frac{1}{2}$ | 2c+3c+1c set as in DTr
- 9- 1c followed by 3c dance up between 2c, cast off ; dance NHJ down through 3pl, cast up to face 1cnrs, 3c looping into 3pl
- 17- 1c turn 1cnrs RH, pass Rsh (cnrs dance for {4}) ; turn 2cnrs RH (same), and cross Rsh to (2,1,3)
- 25- All circle6 and back

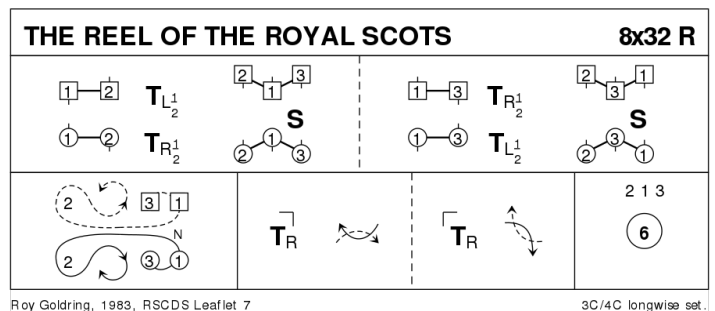

18 EXTRAS

19 THE SAILOR R32 · 3/4L

RSCDS XXIV 4 · Crib: E-cribs · Diagram: Keith Rose's Diagrams

- 1- 1c cross down RH (2c up) to 2plx and BiL with cnrs ; 1c cast R into lines across | all set
- 9- All Reels3 across, Rsh to 1cnr, finishing (2,1x,3)
- 17- 1c lead down | lead to the top ; cross and cast to (2,1,3)
- 25- 2c+1c R&L.

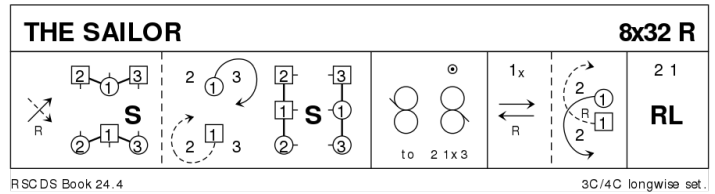

Note: [3-4] is NOT in DT_r position.

20 A CAPITAL JIG J32 · 3/4L

Tine E MacKay: Magazine Dances 2005-2009 · Crib: E-cribs · Diagram: Keith Rose's Diagrams

- 1- 1c+2c Set&Rotate, finish 1c facing 2c (2,1,3)
- 9- Rsh Reels3 on the sides
- 17- 1c set | turn 3/4 RH ; 2c+1W & 1M+3c LHA (to 2,1x,3)
- 25- 1c set | turn 3/4 RH ; 2c+1M & 1W+3c LHA (2,1,3)

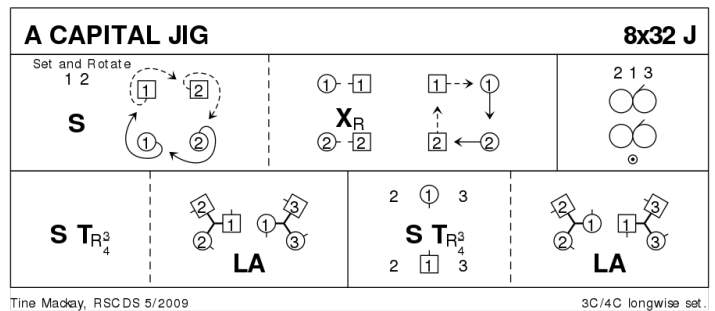

21 THE PAISLEY WEAVERS S32 · 3/3L

Derek Haynes: A Third Book of Graded Scottish Country Dances · Crib: E-cribs · Diagram: Keith Rose's Diagrams

2c start on opposite side (1,2x,3)

- 1- 1c cross down RH | cast down behind 3c ; cross up RH | cast up behind 2c (1,2x,3)
- 9- All G-Ch, 1c cross to start, at end 1M+2M face out for
- 17- 1c+2c L-Chain
- 25- 1c+2c 1/2 R&L ; 1c+3c 1/2 R&L (2,3x,1)

