

Leeds Branch Dance February 2018

1 CUTTY SARK J32 · 3/4L

RSCDS XL 2 · Crib: Eric's E-cribs · Diagram: Keith Rose's Diagrams

- 1- 1c cast off behind own lines (2c up) ; cast up to 2pl
- 9- 2c+1c RHA ; LHA
- 17- 1c turn RH to face 1cnr, turn 1cnr LH ; turn 2cnr RH, cross LH to (2,1,3)
- 25- All A&R ; all turn RH (2,1,3)

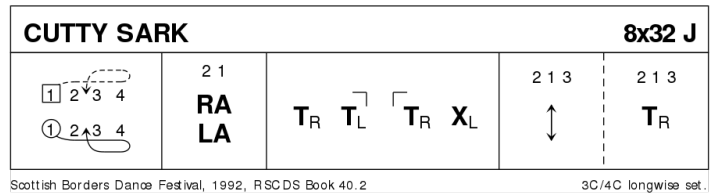

2 MAXWELL'S RANT R32 · 3/4L

Rutherford: RSCDS XVIII 10 · Crib: Eric's E-cribs · Diagram: Keith Rose's Diagrams

- 1- Mirror Reels3 on the sidelines (1c cross down) (1x,2,3)
- 9- 1c cross back into mirror Reels3 on own sides
- 17- 1c cross RH | cast (2c up) ; ½ Fig8 round 2c
- 25- 1c dance down between 3c and cast up to 2pl ; 2c+1c+3c turn RH

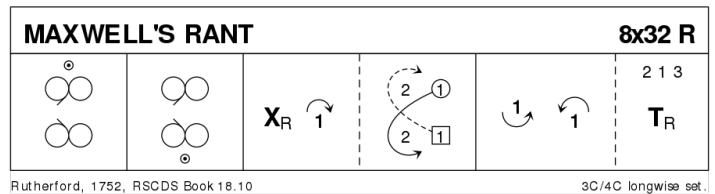

3 AAS YOOOU WIISSSHH S32 · 3/4L

Linda Mae Dennis: The Princess Bride Collection of Scottish Country Dances · Crib: Eric's E-cribs

- 1-- 1c cross RH | cast (2c up) ; turn BH to (2,1x,3)
- 9-- All turn P RH ½ and cast to other side (2x,1,3x) ; All set | all turn P RH ½ into Allemande Hold, 1c facing down
- 17-- 3C Circulating Allemande: On [23-24] 1c finish on opp. side as 2c+3c turn LH ¾ or 1 ¼ to midline, W in middle
- 25-- The Targe: middles turn RH ¾ as outsides chase ¼ cclw | 2c+3c turn P LH while 1c set ; repeat [25-26] | 1c set as 2c+3c turn LH ¾ or 1 ¼ to (2,1,3)

4 GOTHENBURG'S WELCOME J32 · 3/4L

Bobby Munro: RSCDS XXXVII 3 · Crib: Eric's E-cribs · Diagram: Keith Rose's Diagrams

- 1-4 1c cast off one place (2c up) | 1c set advancing to face 1cnrs
- 5-16 Dance to each corner and set (»Free« cnrs set diagonally **while**{ centre dancers change place Rsh with the facing cnr, who in the centre pass Rsh to face next cnr on R | repeat five times, on alternating diagonals), 1c finish facing 3cnr position)
- 17- 1c ½Reel4 on 1diag, pass Rsh ; ½Reel4 on 2diag (2,1,3)
- 25- 2c+1W & 1M+3c RHA ; 2c+1c+3c turn RH.

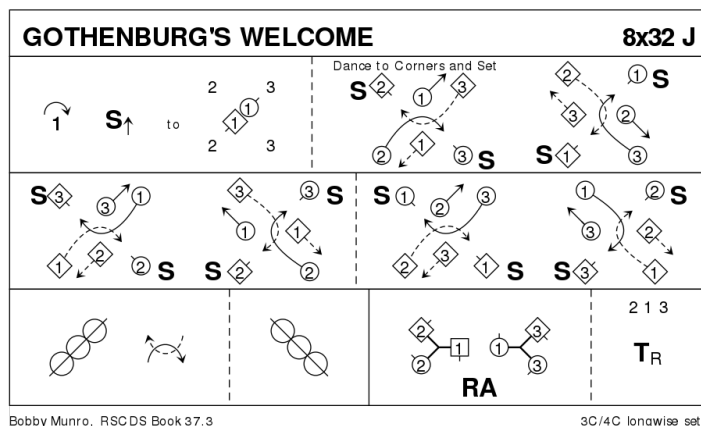

5 THE COUNTESS OF DUNMORE'S REEL R32 · 3/4L

Deirdre MacCuish Bark: RSCDS XLIX 12 · Crib: SCDDDB Contributed Cribs & Diagrams · Diagram: Keith Rose's Diagrams

- 1-- 1c set | dance down (2c up) ; cast up round 3c | set advancing to face 1cnr
- 9-- 1c turn 1cnrs RH, pass Rsh; turn 2cnrs RH, pass Rsh to face out in 2pl (cnrs dance for {4})
- 17-- [3C Chain Progression] 1c cast ¼ clw round set while{ 2c & 3c Turn RH ¾ | 2M+3W turn 1½ LH while{ the others promenade ½ clw round set | 3c+2c turn RH ¾ while{ 1c dance clw to 2pl
- 25-- all chase ½ way clw ; set - cross RH

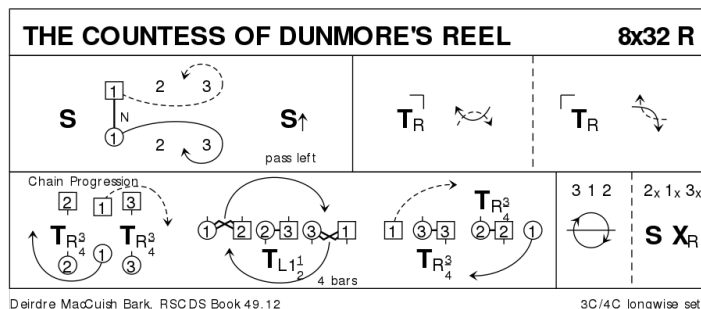

3C Chain Progression was earlier known as Chaperoned Chain Progression

6 CULLA BAY S32 · 4S

Ann Dix: RSCDS XLI 2 · Crib: Eric's E-cribs · Diagram: Keith Rose's Diagrams

- 1- 1c+3c turn RH ½ with person opposite, face that person | twirl R and into opposite place ; 2c+4c repeat this and face in **while**{4} 1c+3c (W leading) chase ¼ clw | curve into centre and swivel R to face out (1c facing 4pl and 3c facing 2pl)
- 9- Parallel Reels4 across
- 17- 2c+1c & 3c+4c circle4 L ; face other couple and set | ½ RHA, flowing into
- 25- 2c+4c LHA in the middle ; dance out passing same sex standing dancer on the side Rsh, and chase R (M leading) to 1pl/3pl (to 2,3,4,1).

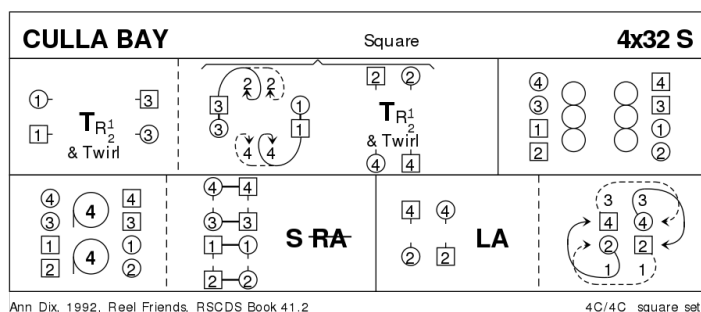

7 MUIRLAND WILLIE J32 · 3/4L

RSCDS XXI 9 · Crib: Eric's E-cribs · Diagram: Keith Rose's Diagrams

- 1- 1c lead down to 3pl, cross and cast to 2pl, **while** 2c set and cross RH into 3pl, **while** 3c cast to top and cross RH ; all C set (may advance a bit) and turn BH to own side (3,1,2)
- 9- Repeat [1-8] from new positions (2,3,1)
- 17- 1c lead to top (2c+3c down) ; 1c set | 1c+2c set advancing
- 25- 1c+2c Poussette (2,1,3).

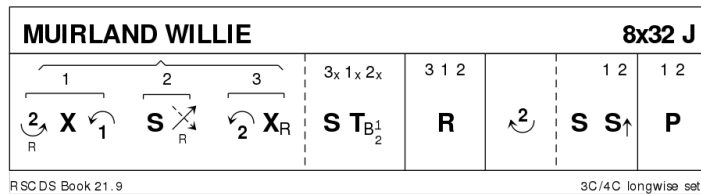

Unofficial: On 2nd turn, 4c has an easier start if 1c+3c+4c dance a 3c Poussette

8 INVERNEILL HOUSE R32 · 3/4L

John Drewry: RSCDS XXXV 2 · Crib: Eric's E-cribs · Diagram: Keith Rose's Diagrams

- 1- 1c+2c 1/2 DbIFig8 (to start, 1c cross down and 2c dance up, 2c finish facing out) ; 1c dance down NHJ between 3c and cast up to 2plx **while** 2c cast up and stand (2x,1x,3)
- 9- 1c+3c 1/2 DbIFig8 (1c cross down and 3c dance up) ; 1c dance up NHJ between 2c and cast off to 2pl own side (2x,1,3x)
- 17- 1c Petronella {8} (to 2x,1x,3x)
- 25- 2c+3c Petronella {8} **while** 1c casts Rsh back | cross (M / W between 3c /2c) ; cast to 2pl | set with 2c+3c (2,1,3)

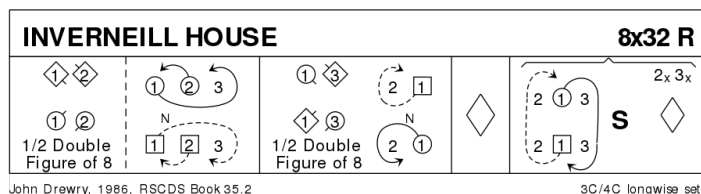

9 INTERVAL

10 COATS LAND J32 · 3/4L

Roy Goldring: The Scotia Suite of Scottish Country Dances · Crib: Eric's E-cribs · Diagram: Keith Rose's Diagrams

- 1- 1c long cast to 3pl (2c+3c up) ; 2c+3c+1c set & turn RH 1/2 to face down for
- 9- 2c+3c+1c Allemande (start down) (to 1x,3x,2x)
- 17- All M (1M leading) chase 1/2 cclw **while** {4} all W (1W leading) chase 1/2 clw inside the men ; 1c dance to top and cast off one (3c down) (2,1,3)
- 25- Teapots R ; and L (1M+3c & 1W+2c RHA ; 1M+2c & 1W+3c LHA)

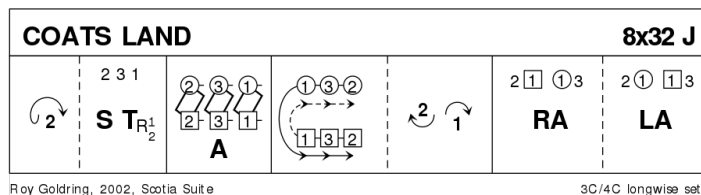

11 PRESTON MILL R32 · 5/5L

Margaret Martin: RSCDS XLV 7 · Crib: Eric's E-cribs · Diagram: Keith Rose's Diagrams

- 1- 1M+2M+4W+5W all dance Fig8 round P and dancer to the R (pass between, cast R, dance up and Lsh round P) to places, at end 1M and 3W face out
- 9- 1M (1W follows) & 3W (3M follows) cast off (2c+4c up) and cross (to 2,1x,4,3x,5) ; 2c+1c & 3c+5c LHA
- 17- 1c+3c set advancing swiveling R into DTr position facing opposite sides | All dance 6 bars of Double DTr (1c+3c now face own side)
- 25- 1c+3c dance out casting off (4c+5c up) | All set ; All turn P RH (2,4,1,5,3)

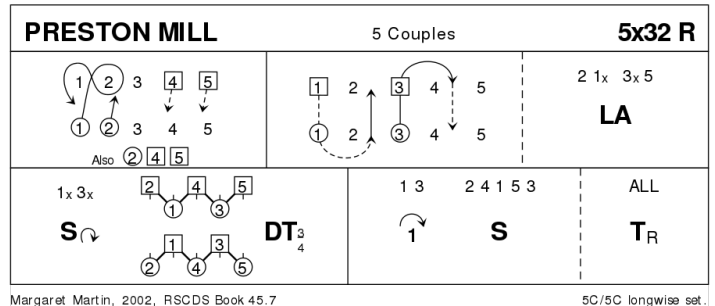

12 THE VALENTINE S32 · 3/4L

Linda C Gaul: Magazine Dances 2005-2009 · Crib: Eric's E-cribs · Diagram: Keith Rose's Diagrams

- 1- 1c set | Turn BH and face down, NHJ ; dance to bottom and cast up (2c up) to (2,1,3)
- 9- 2c+1c DbIFig8 (1c cross up), 1c finish facing 1cnr
- 17-20 1c+1cnrs set **while{2}** 2cnrs set diagonally | 1c dance round P by the R to face 1cnr position again **while{2}** all cnrs chase 1 place clw ;
- 21-24 1c+facings corners set **while{2}** other corners set diagonally | 1c dance round P by the R to 2plx **while{2}** all cnrs chase 1 place clw (3x,1x,2x)
- 25- All C turn RH ½ and face P close by | set in lines of 3 (join H) and all face up; all C dance to top, casting off (2c looping) into (2,1,3)

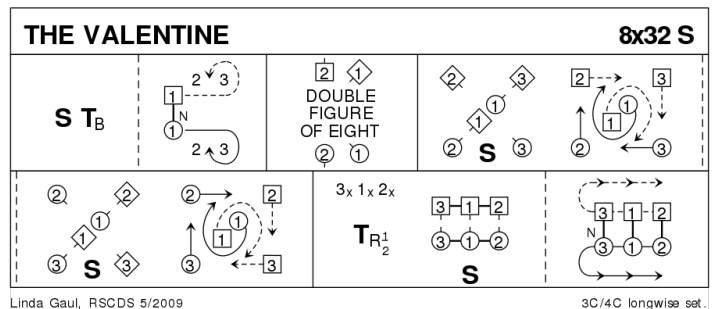

13 BEST SET IN THE HALL J32 · 3/4L

Helen Greenwood: RSCDS XLVI 7 · Crib: Eric's E-cribs · Diagram: Keith Rose's Diagrams

- 1- 1c set | 1W (1M follows) casts off 2, crosses, W dances up behind M line, and M dances up the middle, 1c face 1cnr (2c up)
- 9- 1c set to 1cnr | 1c cast Rsh round each other to 3cnr position **while{2}** 1cnrs dance into centre, and swivel R to face own cnr ; repeat, 1cnrs finishing in exchanged places, and 1c facing 2cnr
- 17- Repeat with 2cnrs (3x,1x,2x)
- 25- All chase clw ½ round ; all turn RH. (2,1,3)

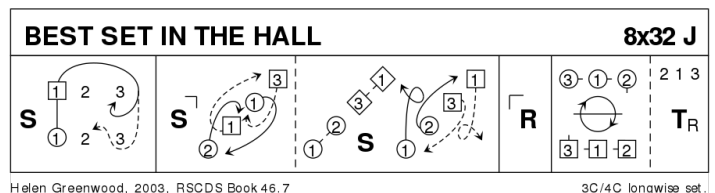

To: Auckland Region President, Campbell MacKay, nov. 2003

14 THE IRISH ROVER R32 · 3/4L

James B Cosh: *Twenty Two SCD · Crib: Eric's E-cribs · Diagram: Keith Rose's Diagrams*

- 1- 1c lead through 3c (2c up) and cast up ; 1M+3c and 1W+2c RHA, finish facing 1cnrs.
- 9- 1c+1cnrs ½Reel4, pass Lsh ; ½Reel4 with 2cnrs, fast ¾ LH turn in the centre
- 17- 1W+3c (at top) & 1M+2c Reels3 across (Lsh to 1cnr pos), (to 3x,1,2x)
- 25- diagonal R&L (1M down,1W up) (2,1,3)

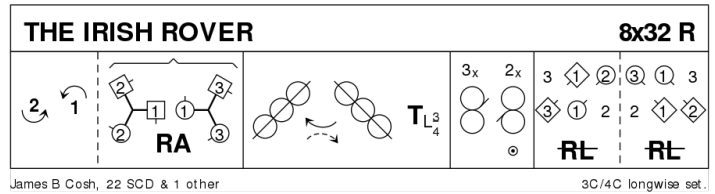

15 CAPE TOWN WEDDING S32 · 3/4L

Tom Kerr: *RSCDS XXXIX 4 · Crib: Eric's E-cribs · Diagram: Keith Rose's Diagrams*

- 1- 1c cross down (no hands) to 2plx (2c up) | change places with 3c EH ; 1c turn RH ½ | lead to top (2c+3c down) and face up in promhold
- 9- 1c with 2c Rsh Reel3 across to finish 1c in 1pos facing down NHJ and 2c in 2pl, on [16] 3c step in and face up NHJ
- 17- All set, all Petronella (1c+3c in tandem) ; all set advancing {1} to join hands in circle, **while** setting {1} pull Rsh back tightly | and cast clw (to 1,2,3)
- 25- 1c+2c the Knot

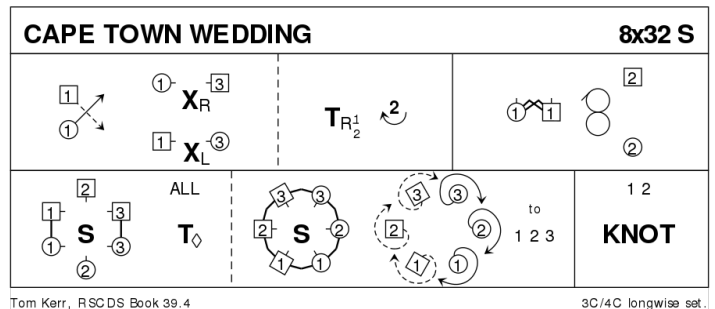

16 IT'S JUST FOR FUN J32 · 3/4L

Roy Fidler: *RSCDS XXXIII 6 · Crib: Eric's E-cribs · Diagram: Keith Rose's Diagrams*

- 1- 1c cross RH | cast off (2c up) ; ½Fig8 round 3cnr, pass Lsh to face 1cnr
- 9- ½Reel4 with 1cnrs, pass Lsh ; Teapots R (1M+2W+3W (at top) & 1W+2M+3M RHA) finish facing 2cnrs
- 17- ½Reel4 with 2cnrs, pass Lsh ; Teapots R on own sides (1M+2W+3W & 1W+2M+3M RHA)
- 25- 1c turn LH ½ (1M faces up, 1W down) **while**{2} all cnrs change places RH on sides (polite turn) | 1c dances out the end and L to 2pl **while**{4} 2c+3c set to P and cross RH | All set (2,1,3).

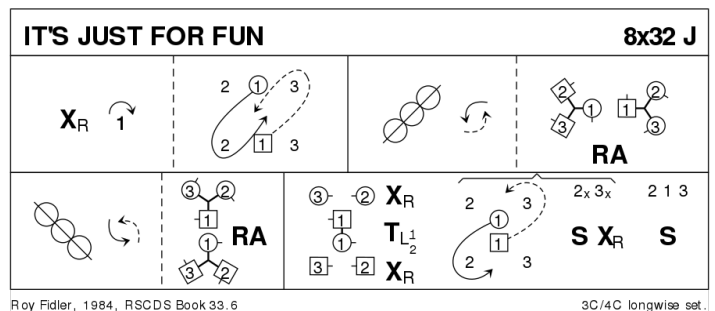

17 THE REEL OF THE ROYAL SCOTS

R32 · 3/4L

Roy Goldring: *The Leaflet Dances with Music* · Crib: *Eric's E-cribs* · Diagram: *Keith Rose's Diagrams*

- 1- 1W+2W (1M+2M) turn LH (RH) ½, finishing 1c BtoB in 2pl | All set as in DTr; 1W+3W (1M+3M) turn RH (LH) ½ | 2c+3c+1c set as in DTr
- 9- 1c followed by 3c dance up between 2c, cast off; dance NHJ down through 3pl, cast up to face 1cnrs, 3c looping into 3pl
- 17- 1c turn 1cnrs RH, pass Rsh (cnrs dance for {4}); turn 2cnrs RH (same), and cross Rsh to (2,1,3)
- 25- All circle6 and back

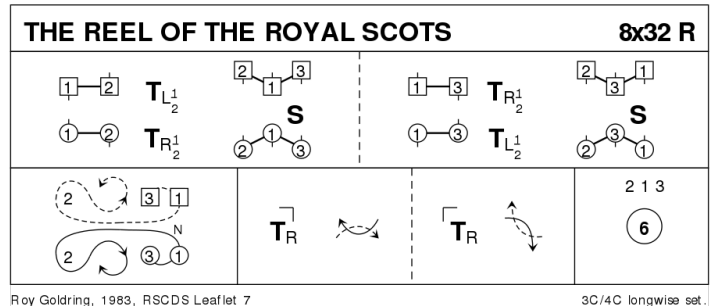

18 EXTRAS

19 CITY OF BELFAST S32 · 3/3L

Lucy Mulholland: *RSCDS XLVIII 6* · Crib: *Eric's E-cribs* · Diagram: *Keith Rose's Diagrams*

- 1- 1c ½ Fig8 round 2c; 1c turn 2c EH 1¼ into line across, 1c in the middle
- 9- 1c+2c Reel4, finish 2c in 1pl and 1c (last pass is Lsh) facing 1cnr
- 17- 1c set to 1cnr | set to 2cnr, dancing R into sideline (2,1x,3); All set | 1c cross RH
- 25- 1c+3c Espagnole (2,3,1)

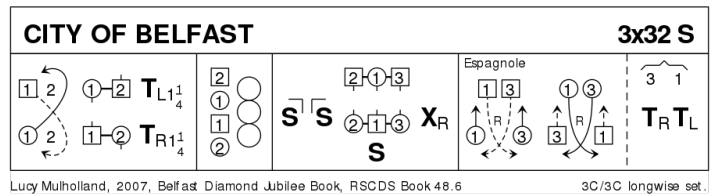

Espagnole: both W lead RHJ to M side, cross and cast back to exchanged places while Men cross to W side, lead RHJ back to M side crossing to exchanged places; all turn P EH (2,1)

20 THE MONTGOMERIES' RANT R32 · 3/4L

Castle Menzies (18C): *RSCDS X 1* · Crib: *Eric's E-cribs* · Diagram: *Keith Rose's Diagrams*

- 1- 1c cross RH | cast off (2c up); cross LH | cast L (W up, M down)
- 9- 2c+1W & 1M+3c Rsh Reels3 across
- 17- 1c NHJ set to 2W (swivel ½ inwards), set to 3M (veer L together), set to 3W (swivel ½ inwards), set to 2M (and face own 2cnr)
- 25- Reels3{6} on the sides, Rsh to 2cnr | 1c cross RH to 2pl

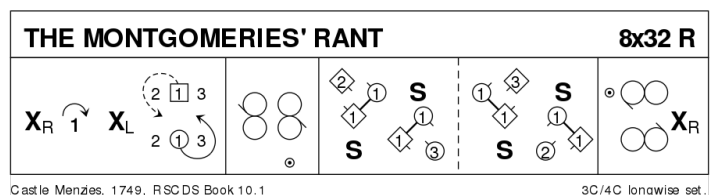

21 PELORUS JACK J32 · 3/4L

Barry Skelton: RSCDS XLI 1 · Crib: Eric's E-cribs · Diagram: Keith Rose's Diagrams

- 1- 1c cross RH, cast (2c up) ; 1c+3c RHA, finish 1M facing 1c, 1W behind him
- 9- 1c in tandem +1cns ½ diagonal Reel3, Rsh to 3W (1M & 1W loop R singly for lead change, so 1W now leads P) ; ½ diagonal Reel3, Rsh to 2W (+ lead change)
- 17- Continue pattern twice
- 25- 2c+1c LHA ; 1c turn LH ½ | all set (2,1,3)

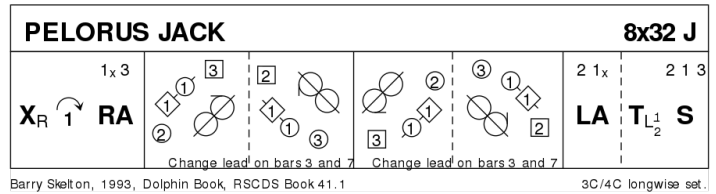

22 A TRIP TO BAVARIA R32 · 4/4L

James MacGregor-Brown: Collins Pocket Reference: Scottish Country Dancing · Crib: Eric's E-cribs · Diagram: Keith Rose's Diagrams

- 1-16 1c+4c cross RH, while{} 2c+3c ½RHA | middle and end Cs change place LH on sides ; repeat 3 times, finish (1,2,3,4) 1c facing down, 2c up
- 17- 1c set to 2c | cross down to face 3c (2c dance up) ; 1c+3c repeat
- 25- 1c+4c repeat ; All A&R, 1c changing sides RH on [30] (2,3,4,1)

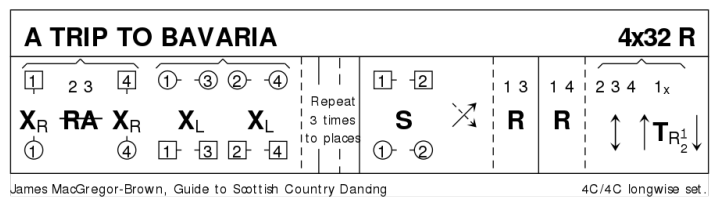

Note: on [30] the original says »RH«, but »BH« is widely used.