

# Leeds Club Dance Summer Special

St Chad's Parish Centre

## 1 TAMBOURINE R32 · 3/4L

Lawrie Bowlen: *East Ivanhoe Book* · Crib: *E-cribs* · Diagram: *Keith Rose's Diagrams*

- 1- 1c lead down the middle (2c up) and up to 2pl
- 9- ½Reels3 across, Lsh to 1cnrs ; ½Reels3 on sidelines (Rsh to 2cnr pos), cnrs end with loop
- 17- ½Reels3 across, Lsh to 3cnr pos ; ½Reels3 on sidelines (Rsh to 4cnr pos) (to 2,1,3) (1c and 2cnrs move cclw, 1cnrs move clw)
- 25- 2c+1c+3c circle6 and back

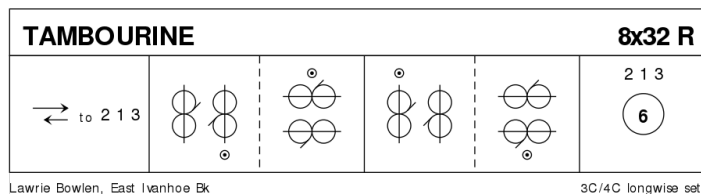

## 2 THE GRUMPY GENTLEMAN J32 · 3/4L

Gillian Jennings: *Birmingham Diamond Jubilee Dance Book - 1946-2006* · Crib: *MiniCribs* · Diagram: *Keith Rose's Diagrams*

- 1-8 1s+2s Set & Rotate :  
Set, rotate singly & dance on 1 place clockwise, change places RH on sides & dance on 1 place to own sides (1s in 2nd pl)
- 9-16 1s dance LSh round 3s & dance 1/2 reel of 3 on sides (RSh to 2s to start) & end facing 1st corners (pstr)
- 17-24 1s dance 1/2 diagonal reel of 4 with 1st corners, pass RSh & dance 1/2 diagonal reel with 2nd corners to end 2nd place opposite sides
- 25-32 All set twice & 1/2 turn partner, twirl & dance out to places

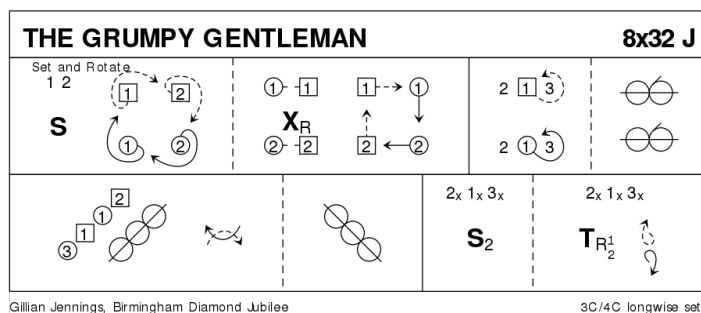

### 3 FAR NORTH QUEENSLAND S32 · 5/5L

John Brendchley: *The Other Kangaroo Paw* · Crib: *MiniCribs* · Diagram: *Keith Rose's Diagrams*

- 1-4 1s+ 5s cross RH & cast down/up 1 place (2s+4s step up/down)
- 5-8 1M+2s also 1L+3s+5M also 5L+4s dance circles round to Left. 1s+5s end in middle facing partners (Men facing down, Ladies facing up)
- 9-16 1s+5s set, dance 1/2 reel of 4, set advancing to partners, pass LSh to face 2nd corner positions
- 17-24 1s+5s dance 1/2 diag. reel of 4 with 2nd corners, turn LH to face 1st corner positions, dance 1/2 diag. reel of 4 with 1st corners, turn LH to face 4th corner positions (partner's 2nd corner position)
- 25-32 1s+5s dance 1/2 diag. reel of 4 with 4th corners, turn LH to face out on own sides, cast 1 place (3s+2s step up 31-32) 4 3 5 2 1

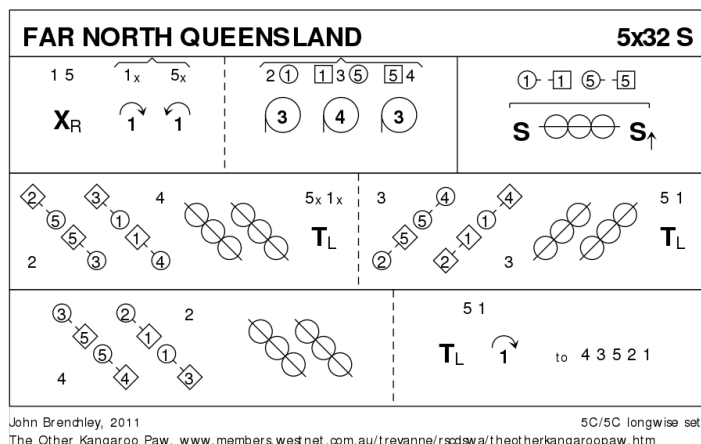

### 4 THE MEETING OF THE WATERS R48 · 3/4L

Iain Boyd: *The Strathtay Album* · Crib: *E-cribs* · Diagram: *Keith Rose's Diagrams*

- 1- 1c+2c Reel4 across, 1M+2W pass Lsh as 1W/2M cast down/up, finish in places (1W+2M final pass is Rsh)
- 9- 1c parallel Rsh Fig8 on own side round 2c+3c
- 17- 1W, followed by 1M, cast off behind 2W, cross down between 3c (2c up), cast up round 3M, (to 2,1,3)
- 25- 1c+3c RHA ; 2c+1c LHA
- 33- 2c+1c+3c parallel Reels3 on the sides (1c Rsh to 3c)
- 41- All Circle6 and back

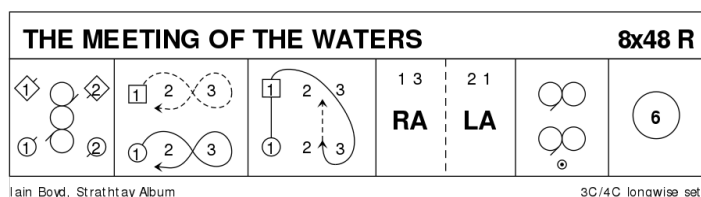

## 5 THE DANDELION PICKER R32 · 3/4L

Ian Barbour · Crib: MiniCribbs · Diagram: Keith Rose's Diagrams

- 1-8** 1s turn RH & cast 1 place (2s step up), 1s turn LH to face 4th corners
- 9-16** 1s dance 1/2 Diag reel with 4th cnrs & pass RSh to face 1st corners, 1s dance 1/2 Diag reel with 1st cnrs to end 1L between 3s (at top), 1M between 2s (3rd place)
- 17-24** 1s dance Diag R&L (up/down):  
**17-20** 1s change places RH with dancer diagonally to Right, dancers change places LH at ends of set  
**21-24** 1s change places RH with dancer diagonally to Left, dancers change places LH at ends of set. 1s end facing 4th corners
- 25-32** RSh reels of 3 across, 1L+2s (at top) & 1M+3s (at bottom) & 1s cross RH to own sides bars 31-32

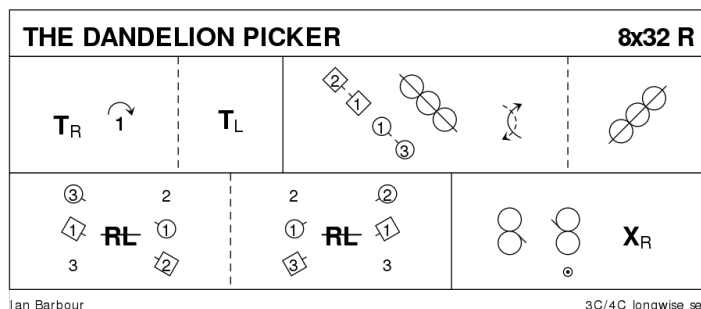

## 6 CITY OF BELFAST S32 · 3/3L

Lucy Mulholland: RSCDS XLVIII 6 · Crib: E-cribs · Diagram: Keith Rose's Diagrams

- 1-** 1c 1/2 Fig8 round 2c ; 1c turn 2c EH 1 1/4 into line across, 1c in the middle
- 9-** 1c+2c Reel4, finish 2c in 1pl and 1c (last pass is Lsh) facing 1cnr
- 17-** 1c set to 1cnr | set to 2cnr, dancing R into sideline (2,1x,3) ; All set | 1c cross RH
- 25-** 1c+3c Espagnole (2,3,1)

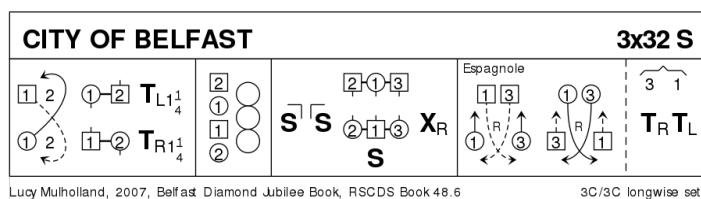

Espagnole: both W lead RHJ to M side, cross and cast back to exchanged places while Men cross to W side, lead RHJ back to M side crossing to exchanged places ; all turn P EH (2,1)

## 7 BLOOMS OF BON ACCORD R32 · 4/4L

John Drewry: Deeside Book Part 2 · Crib: E-cribs · Diagram: Keith Rose's Diagrams

3c+4c cross on 2nd chord(1,2,3x,4x). This dance has top/bottom symmetry

- 1-** All C set | 1c+2c & 3c+4c RHA | 1c & 4c cast in to 2pl/3pl while {2} 2c+3c lead out to end places
- 9-** 1c+4c cross RH, cast to ends, meet in promhold and dance in between end couples, curve round the other couple Rsh to finish 1c / 4c on M/W side facing out and right
- 17-** 1c & 4c (in promhold) Rsh Reels3 with the »corners« on M/W sides, at end meet in the centre
- 25-** 4c+1c RHA, at end M swivels right so couples face ends of set (1c down, 4c up, W on P's left, RHJ) ; 4c&1c cross down between end couples and cast in to 3pl/2pl (to 2,4,1x,3x)

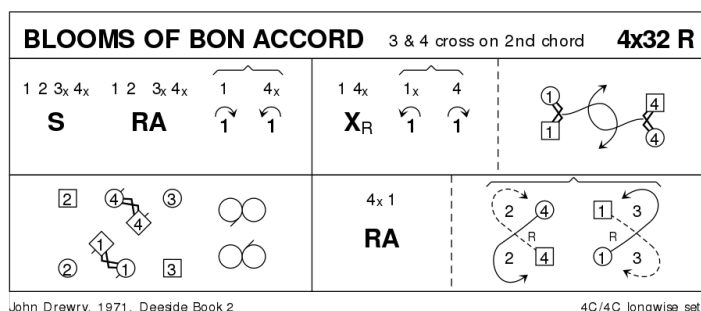

## 8 GLASTONBURY TOR R32 · 3/4L

Duncan Brown: RSCDS XLVII 11 · Crib: E-cribs · Diagram: Keith Rose's Diagrams

- 1- 1c+2c set | ½ RHA ; 1c+3c set | ½ LHA (2x,3x,1)
- 9- 1c set | cross RH ; cast up one (3c down) | turn LH to face 1cnr (pos)
- 17- ½ diag Reel4 with 1cnrs, pass Lsh ; ½ diag Reel4 with 2cnrs, 1c curve R into facing lines of 3 across, 1M at top, 1W at bottom
- 25- All S&Link3 ; 1c turn RH 1½ while{4} cnrs chase clw ½ round (2,1,3)

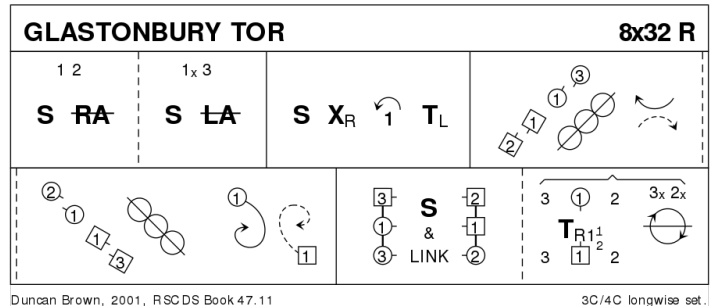

## 9 PROGRAMME ITEM – Interval

## 10 MISS JOHNSTONE OF ARDROSSAN R32 · 5/5L

Roy Goldring: 14 Social Dances for 2000 · Crib: E-cribs · Diagram: Keith Rose's Diagrams

- 1- 1c set | cast off (2c up) ; 1c followed by 3c dance up and cast round 2c to (2,3,1,4,5)
- 9- 1c+4c+5c mirror Reels3, 1c cross down to enter, 4c start out and up (2,3,1x,4,5)
- 17- 2c+3c+1c mirror Reels3, 1c cross up to enter, 3c start out and down
- 25- 1c set | cast off to 4pl (4c up) ; 1c followed by 5c dance up and cast round 4c to (2,3,4,5,1)

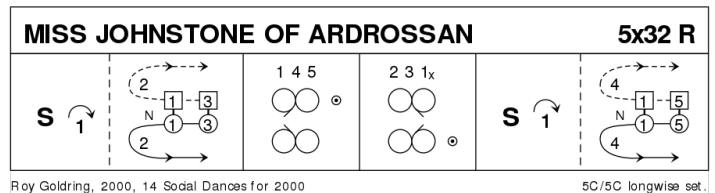

## 11 MACLEOD'S FANCY J32 · 4/4L

John Drewry: RSCDS XXXIII 3 · Crib: E-cribs · Diagram: Keith Rose's Diagrams

- 1- 1c+4c set facing diagonally | 1W+4M cast R round own sideline and meet with ¾ RH turn in the middle, to places while{6} 1M+4W make that turn and cast R round own sideline to places
- 9- All dance Reels4 on the sides to finish (1,2,3,4) facing up/dn
- 17- Middles (2c+3c) turn ends RH ½ way to form a St Andrew's Cross (1c+4c retain RH and give LHA in the middle) | all set ; continue turns once round RH, at the end 1c+4c pass Rsh on own side to end (2,4,1,3) (1M+4W with polite turn)
- 25- (Middle couples solo:) 4c+1c set, Women cross NHJ and face ends while{2} Men cross over outside them and turn inwards to join P ; 4c(1c) lead up RH (lead down LH) between 2c(3c), cross and cast to 2pl(3pl) (2,4,1,3)

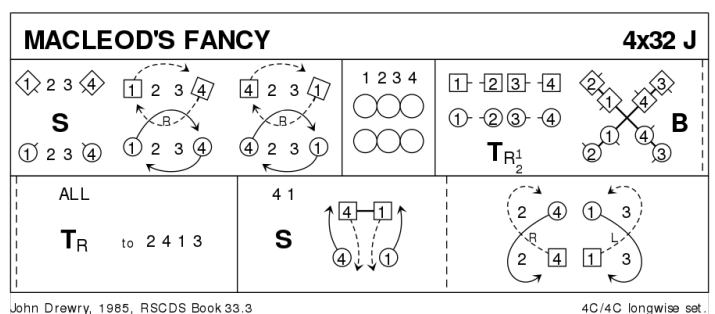

## 12 CHASING THE ECLIPSE S32 · 3/3L

Sandy Gallamore: *The Highland Road Collection* · Crib: *SCDDB Contributed Cribs & Diagrams* · Diagram: *Keith Rose's Diagrams*

- 1-8 1C set, dance NH down the center + cast up to 2pl & cross to face 1cnr.
- 9-16 Reel 3 on sides - 1C pass 1cnr Rsh to begin.
- 17-24 1C+1cnr set , 1C spiral Rsh rnd ptrn to face 2cnr ; 1C+2cnr set , 1C spiral Rsh to face out 2pl own side.
- 25-32 All dance Chaperoned Chain Progression. End 3 1 2.

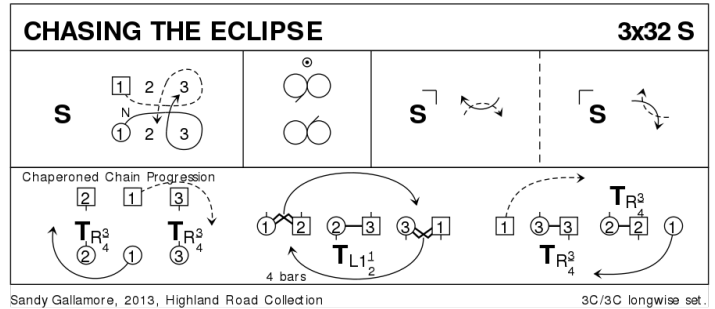

## 13 NOTTINGHAM LACE R96 · 4S

Jenny Bradley: *Nottingham Lace* · Crib: *E-cribs* · Diagram: *Keith Rose's Diagrams*

- 1- Half G-Chain ; all set to P | turn 3/4 RH
- 9- All W 1/2LHA while{2} M dance clw one place | all turn new P RH 1/2 ; repeat (M 1/2LHA, W 1/4 clw)
- 17- Repeat [9-16] to original places
- 25- 1c+3c dance in, change places RH, split and cast behind side C, pass RH to own place, forming a longwise set | All set
- 33- All A&R ; 1c+2W+4M & +3c+2M+4W, circle4 L and open into lines of 4 across with 1c & 3c in the middle
- 41- All A&R ; circle8 half way, finishing in square set opposite original places
- 49-72 Repeat [25-48] with 2c+4c as dancing couples
- 73-96 Repeat [1-24]

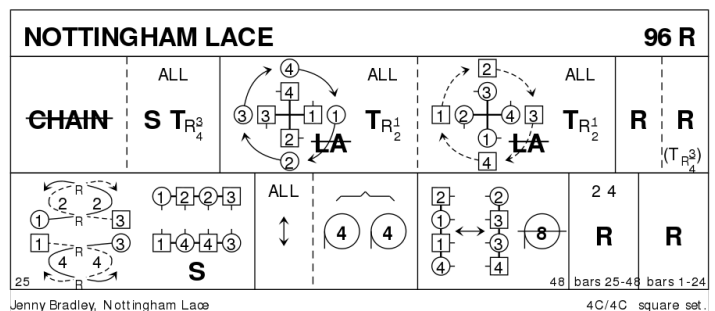

## 14 BLACKFORD JIG J40 · 3/4L

Evelyn Ramwell: *Kirkbrae Collection of SCDs* · Crib: *MiniCribs* · Diagram: *Keith Rose's Diagrams*

- 1-8 1s lead down the middle & back, cast to 2nd place on own sides
- 9-16 1s dance 1/2 Figs of 8 (Lady round 2s & Man down round 3s), turn to face 1st cnr & turn cnr LH (4 bar turn) 1s end in 2nd pl opp sides
- 17-24 1s dance reels of 3 on opposite sides giving RSh to 2nd corner to start (end facing 2nd corners)
- 25-32 1s turn 2nd corners RH (4 bar turn) & dance 1/2 Figs of 8 (Man up round 2s & Lady down round 3s)
- 33-40 1s dance reels of 3 across giving LSh to 1st corners

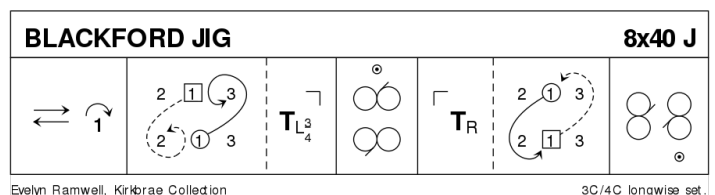

## 15 THE GLENGARRY HOMESTEAD

S32 · 4/4L

John Brenchley: *The Kangaroo Paw* · Crib: *E-cribs* · Diagram: *Keith Rose's Diagrams*

- 1-- 1c ½ Fig8 with 2c **while{4}** 3c ½ Fig8 with 4c ; 1c&3c dance down one and turn inwards to face up NHJ **while{4}** 2c&4c dance up one on sidelines, turn inwards to face down NHJ | All set
- 9-- 2c+1c & 4c+3c Circle4 to L ; ½ Reels4 on sidelines, on [15-16] 1c+4c turn LH ¾ to finish in line across, W in centre, ready for
- 17-- 1c+4c [The Targe:] W turn RH ¾ as M chase cclw ¼ onto midline | W+M turn LH ; repeat [17-20] to finish on sidelines (3x,1,4x,2)
- 25-- ½ Reels4 on sidelines ; All set | 4c&3c cross RH (2,4,1,3)

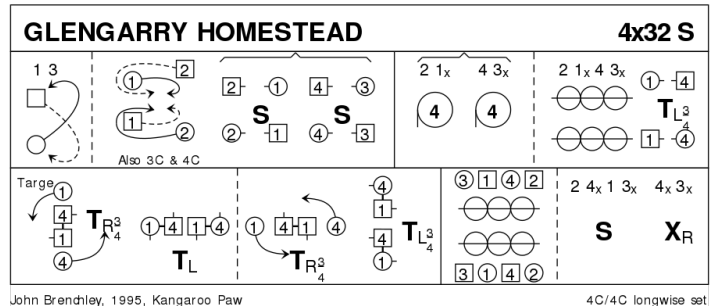

## 16 BEST SET IN THE HALL

J32 · 3/4L

Helen Greenwood: *RSCDS XLVI 7* · Crib: *E-cribs* · Diagram: *Keith Rose's Diagrams*

- 1-- 1c set | 1W (1M follows) casts off 2, crosses, W dances up behind M line, and M dances up the middle, 1c face 1cnr (2c up)
- 9-- 1c set to 1cnr | 1c cast Rsh round each other to 3cnr position **while{2}** 1cnrs dance into centre, and swivel R to face own cnr ; repeat, 1cnrs finishing in exchanged places, and 1c facing 2cnr
- 17-- Repeat with 2cnrs (3x,1x,2x)
- 25-- All chase clw ½ round ; all turn RH. (2,1,3)

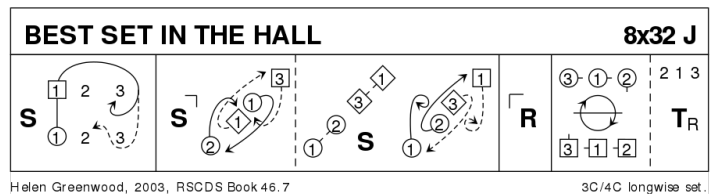

To: Auckland Region President, Campbell MacKay, nov. 2003

## 17 THE MONTGOMERIES' RANT

R32 · 3/4L

Castle Menzies (18C): *RSCDS X 1* · Crib: *E-cribs* · Diagram: *Keith Rose's Diagrams*

- 1-- 1c cross RH | cast off (2c up) ; cross LH | cast L (W up, M down)
- 9-- 2c+1W & 1M+3c Rsh Reels3 across
- 17-- 1c NHJ set to 2W (swivel ½ inwards), set to 3M (veer L together), set to 3W (swivel ½ inwards), set to 2M (and face own 2cnr)
- 25-- Reels3{6} on the sides, Rsh to 2cnr | 1c cross RH to 2pl

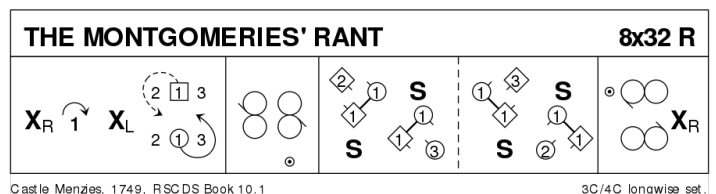

## 18 PROGRAMME ITEM – Extras

## 19 BROADFORD BAY R32 · 3/4L

Anne Grant: *The Leaflet Dances with Music* · Crib: *E-cribs* · Diagram: *Keith Rose's Diagrams*

- 1- 1c (leading)+2c (dance up to begin), dance between 3c, cast up and dance to top, and 1c cast off (to 2,1,3)
- 9- 2c+1c+3c G-Chain (2c cross to start), finish 2M & 1W facing out (2,1,3)
- 17- 2W+1M turn RH 1½ **while{4}** 2M+1W chase ½ round cclw ; 2W+1M chase ½ round clw to 1W/2M places **while{4}** 2M+1W turn LH 1¼ to face P on 2diagonal
- 25- 2c+1c diagonal Reel4 (to 2,1,3)

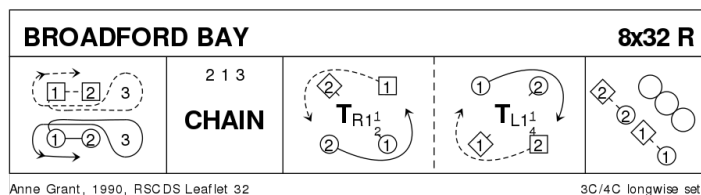

## 20 THE BYRON STRATHSPEY S32 · 3/3L

John Drewry: *Deeside Book Part 2* · Crib: *E-cribs* · Diagram: *Keith Rose's Diagrams*

- 1- 1c+2c+3c Petronella Turn into midline, set ; all turn P BH 1¼ to (1,2,3)
- 9- "Teapots": 1c+2W & 2M+3c RHA ; 1c+2M & 2W+3c LHA , to (1,2,3) with 1c facing out and 2c facing up in promhold
- 17- 2c (promhold) +1W+1M Reel3 across (Rsh to 1W), at end all dance in for
- 25- 2c+1c+3c Allemande (to 3,1,2).

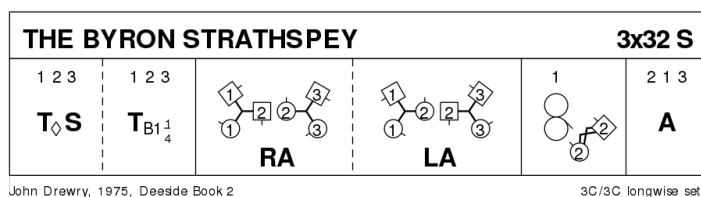

## 21 FLIGHT TO MELBOURNE R32 · 4S

Shirley Campbell: *RSCDS XLVII 3* · Crib: *E-cribs* · Diagram: *Keith Rose's Diagrams*

- 1- 1M+3W (and 1W+3M) Fig 8 round 2c (4c) (W crossing in front of M), to own places
- 9- 1c & 3c in promhold Rsh Reels3 across with the nearest members of 2c & 4c, to places.
- 17- All C S&Link (to face P) ; turn RH ½ | chase 1 place clw. (4,1,2,3)
- 25- All Circle8 and back (4,1,2,3)

