

Leeds Scottish Country Dance Club 27 April 2019

St Chad's Parish Centre 7.30pm

Music: Neil Barron MCs: Patricia Lynch and Lesley Enoch

1 MISS ALLIE ANDERSON J32 · 3/4L

Mina Corson: *The Leaflet Dances with Music* · Crib: *E-cribs* · Diagram: *Keith Rose's Diagrams*

- 1- All clap, 1W+2W+3W dance Rsh once round P to face down with him RHJ ; All lead down the middle
- 9- All M turn P under R arm and lead up to (1x,2x,3x) ; All set, ½ RH turn into
- 17- 1c+2c+3c Promenade (1,2,3)
- 25- 1c+2W RHA, 1M finishing 2pl own side (2M up on [3-4]) ; 1c+2M LHA (2W up on [7-8]) to (2,1,3)

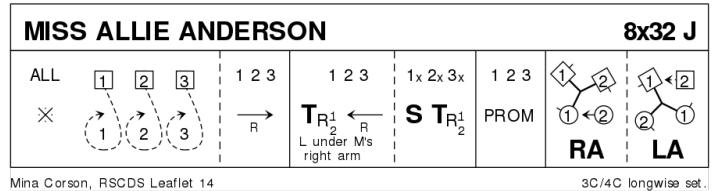

2 THE MONTGOMERIES' RANT R32 · 3/4L

Castle Menzies (18C): *RSCDS X 1* · Crib: *E-cribs* · Diagram: *Keith Rose's Diagrams*

- 1- 1c cross RH | cast off (2c up) ; cross LH | cast L (W up, M down)
- 9- 2c+1W & 1M+3c Rsh Reels3 across
- 17- 1c NHJ set to 2W (swivel ½ inwards), set to 3M (veer L together), set to 3W (swivel ½ inwards), set to 2M (and face own 2cnr)
- 25- Reels3{6} on the sides, Rsh to 2cnr | 1c cross RH to 2pl

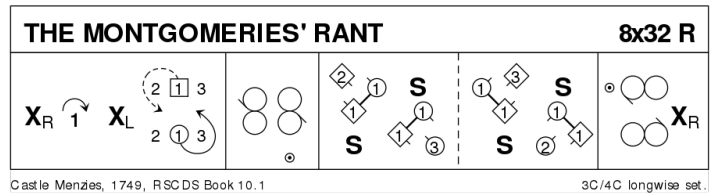

3 RED KITES OVER THE BLACK ISLE S32 · 4/4L

Ann & Ian Jamieson: *The Glen Orrin Collection* · Crib: *MiniCribs* · Diagram: *Keith Rose's Diagrams*

- 1-8 1s & 4s set & cast in 1 place (2s & 3s step up/down), 1s+4s dance 1/2 R&L
- 9-16 2s & 3s set & cast in 1 place (4s & 1s step up/down), 2s+3s dance 1/2 R&L. (4) (3) (2) (1)
- 17-24 4s+3s & 2s+1s dance RH across, 3s+2s dance LH across while 4s & 1s chase clockwise to other end
- 25-32 1s+3s also 2s+4s set facing on sides & change places RH, turn partners 2H to own sides (end couples turn 1.1/2 times)

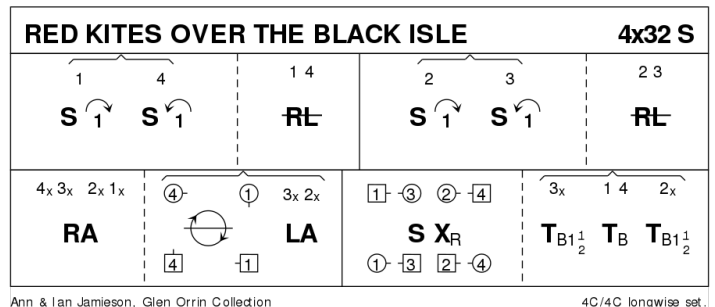

4 LES REMPARTS DE SÉVILLE J32 · 3/4L

Aliénor Latour: RSCDS 50 2 · Crib: E-cribs · Diagram: Keith Rose's Diagrams

- 1-- 1c set | cast off (2c up) ; 1c ½Fig8, Lsh to 1cnr
- 9-- 1c turn LH to face 1cnrs | 6 bars of set H&G, into lines across
- 17-- S&Link3 ; all set | all cross RH
- 25-- Circle6 and back (2,1,3)

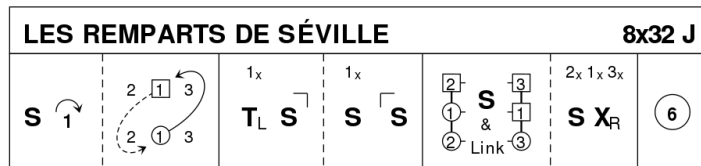

Aliénor Latour, 2014, RSCDS Book 50.2

3C/4C longwise set.

5 SCOTT MEIKLE R32 · 4/4L

Alice McLean: RSCDS XLVI 3 · Crib: E-cribs · Diagram: Keith Rose's Diagrams

- 1-- 1c cross RH | cast (2c up) ; ½ Fig8 up (2,1,3,4)
- 9-- 1c+3c RHA, LHA (2,1,3,4)
- 17-- Lsh opposing Reels3 across: (1W+3W behind dancing as one) with 2c and (3M+1M behind) with 4c (to 2,3,1,4)
- 25-- 1c+4c ½ R&L ; turn RH 1½ (2,3,4,1)

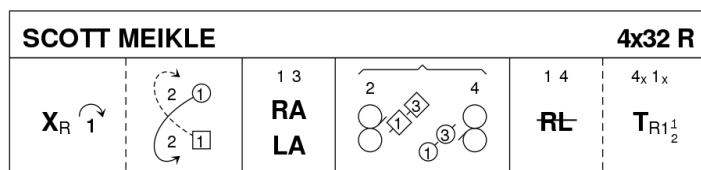

Alice McLean, Laurieston on Collection 1, RSCDS Book 46.3

4C/4C longwise set.

6 BUTTERSCOTCH AND HONEY S32 · 4/4L

Jean Attwood: Alexander Leaflets · Crib: E-cribs · Diagram: Keith Rose's Diagrams

- 1-- 1c set, ½RH turn to promhold facing down ; ½ Rsh Reel3 across with 2c, 2c finish in 1plx
- 9-- ½ Lsh Reel3 across with 3c, 3c finish in 2plx ; repeat Rsh with 4c to (2x,3x,4x,1x)
- 17-- 1c leading, all cast up outside sidelines to the top, cross Lsh to P and dance down on own sidelines (2,3,4,1)
- 25-- All set and turn partners BH ; 2c+3c & 4c+1c Circle4 L.

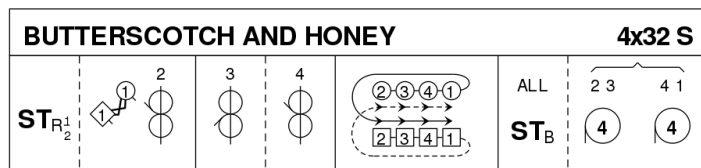

Jean Attwood, Alexander Leaflets

4C/4C longwise set

7 THE REEL OF THE ROYAL SCOTS R32 · 3/4L

Roy Goldring: The Leaflet Dances with Music · Crib: E-cribs · Diagram: Keith Rose's Diagrams

- 1-- 1W+2W (1M+2M) turn LH (RH) ½, finishing 1c BtoB in 2pl | All set as in DTr ; 1W+3W (1M+3M) turn RH (LH) ½ | 2c+3c+1c set as in DTr
- 9-- 1c followed by 3c dance up between 2c, cast off ; dance NHJ down through 3pl, cast up to face 1cnrs, 3c looping into 3pl
- 17-- 1c turn 1cnrs RH, pass Rsh (cnrs dance for {4}) ; turn 2cnrs RH (same), and cross Rsh to (2,1,3)
- 25-- All circle6 and back

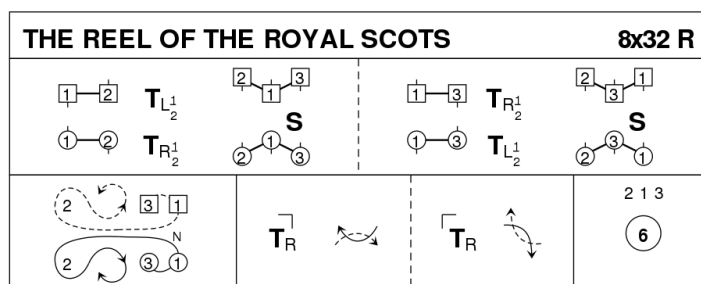

Roy Goldring, 1983, RSCDS Leaflet 7

3C/4C longwise set.

8 MIDNIGHT OIL J48 · 5/5L

John Drewry: Bankhead Book Part 3 · Crib: E-cribs · Diagram: Keith Rose's Diagrams

- 1-- 1c+3c lead far down (2c+4c up) | turn $\frac{3}{4}$ RH and face P, RHJ ; set , W turning under M's arm | 1c+3c dance up (W leading)
- 9-- 1c+2W & 3c+4W RHA ; 1c+4M & 3c+5M LHA, 1c+3c finish facing 1cnrs
- 17-- 1c+3c with 1cnrs pass and turn, pass P Rsh ; repeat with 2cnrs, at end pass P Rsh onto midline, W above and facing M
- 25-- Reel4 on midline, at end pass Rsh in the middle to finish 1c facing out in 2pl on W side / likewise 3c in 4pl on M side
- 33-- 1c dance out between 2W & 4W, split, cast round them, meet in middle, repeat through M side **while{8}** 3c do the same, starting between 4M & 5M. (1M & 3W pass Lsh between 4c). All finish where they started the reel, but 1M faces 3W
- 41-- 1W+3M set twice facing up and down **while{4}** 1M+3W turn RH to face P ; 1c+3c turn P LH $\frac{3}{4}$ | cast off on own side (4c+5c up) (2,4,1,5,3)

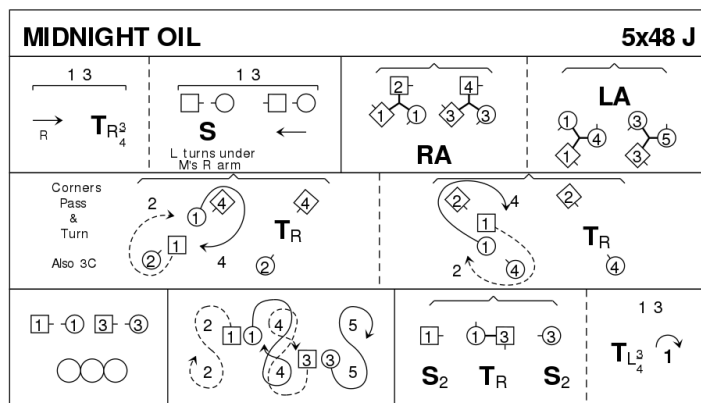

9 RAMADAN-CE R32 · 3/4L

John Drewry: The Turkish Set · Crib: E-cribs · Diagram: Keith Rose's Diagrams

- 1-- 1c+2c+3c Inveran Reels (1,2,3)
- 9-- 1c cross RH | cast (2c up) ; Turn RH to face 1cnr
- 17-- 1c+1cnrs pass Rsh | cnrs turn RH $\frac{1}{2}$ and cast away as 1c meet and pass Rsh to face 2cnrs ; repeat with 2cnrs (3x,1x,2x)
- 25-- $\frac{1}{2}$ Reels3 across, 1c Lsh to 3cnr ; $\frac{1}{2}$ Reels3 on the sides, 1c Rsh to 4cnr (2,1,3)

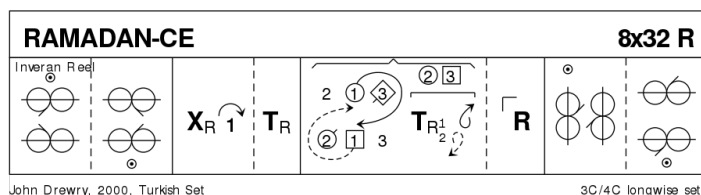

10 PROGRAMME ITEM – Interval

11 THE LAIRD OF MILTON'S DAUGHTER J32 · 3/4L

Craigmyle: RSCDS XXII 10 · Crib: E-cribs · Diagram: Keith Rose's Diagrams

- 1-- 1c set, cross RH ; cast off (2c up), turn LH to 1cnrs
- 9-- Corners' chain: 1c+1cnrs turn $\frac{1}{2}$ RH | 1cnrs turn LH ; 1c+1cnrs turn back RH $\frac{1}{2}$ | 1c turn LH $1\frac{1}{4}$ to 2cnrs
- 17-- Repeat with 2cnrs, 1c crossing LH to 2pl
- 25-- 2c+1c+3c circle6 and back

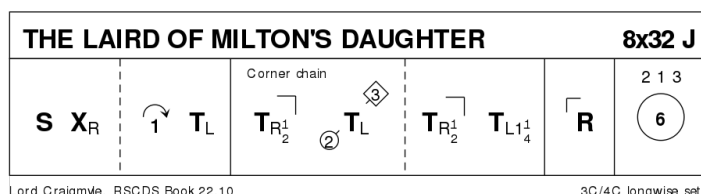

12 J. B. MILNE R32 · 3/4L

Hugh Foss: Angus Fitchet Scottish Dance Album · Crib: E-cribs · Diagram: Keith Rose's Diagrams

- 1– 1M+2W set advancing and turn RH ; 1W+2M repeat
- 9– 1c set advancing | turn BH and open upwards ; cast off one (2c up), Petronella Turn to: 1M between 3c and 1W between 2c
- 17– 1c set, turn $\frac{3}{4}$ RH, set, turn $\frac{3}{4}$ RH, **while**{8} 2c+3c pass RH on the sides, set, cross RH, set
- 25– 1c set, pass RH, cast R into 2pl, **while** {6} 2c+3c pass RH on the sides, set ; cross RH | all set. (2,1,3)

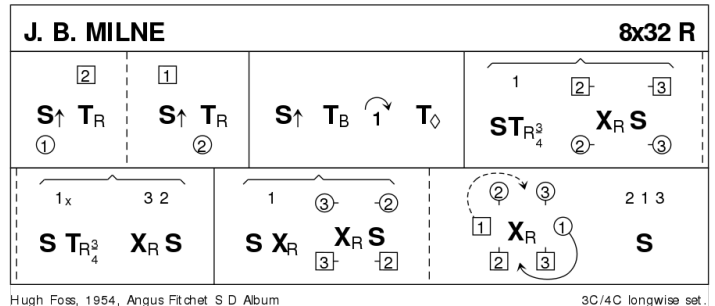

In 17-32, the corners traditionally set one bar to the person you just passed, then one bar to the next person to pass. In a variant for [19-24] 1c turns BH in PdB.

13 ALEC'S LEGACY S32 · 3/4L

Lesley Enoch: Leeds Scottish Country Dance Club 65th Anniversary

14 FATHER CONNELLY'S JIG J64 · 4/4L

John Drewry: The Donside Book · Crib: E-cribs · Diagram: Keith Rose's Diagrams

- 1– 1c+2c Set&Rotate (All set | petronella clw one place ; change places RH with P | chase one place clw) (2,1,3,4)
- 9– $\frac{1}{2}$ diagonal R&L with 1cnrs (W up, M down) **while**{4} the 2cnrs (2M+3W) set & cross RH, all cnrs face out ; $\frac{1}{2}$ Reels3 on the sides, 1c Rsh to 2cnr pos. (no loops at the end) (2x,1x,3x,4)
- 17– Repeat figure from these positions with 2cnr persons (in 3cnr positions ; M up, W down) (to 2,1,3,4), 2c+3c finishing with loops into
- 25– Reels3 across (Lsh to 1cnr) (2,1,3,4)
- 33– 1c cross down RH between 3c | cast Rsh round new 1cnr (4W resp. 3M) ; change places up/dn LH | cast L (3c up) to (2,3,1,4)
- 41-56 3c+1c+4c repeat the figures [9-24] above (2,3,1,4)
- 57– 3c+1c+4c Circle6 and back (optional: 2c join in for Circle8 and back) (1c step down, to 2,3,4,1)

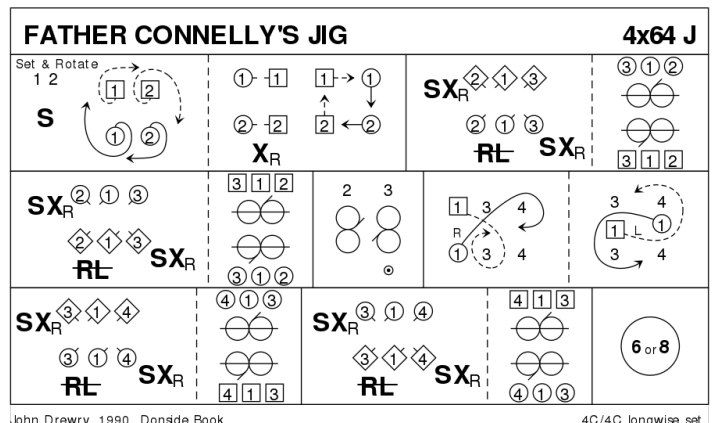

(note by Drewry: This is really two successive 3c dances of 32 bars, the figures of bars 9-24 being similar.

15 THE LADIES OF DUNSE R40 · 3/4L

RSCDS XXVI 11 · Crib: E-cribs · Diagram: Keith Rose's Diagrams

- 1- 1c lead down the middle and up {6}, cast off (2c up)
- 9- 2c repeat (1,2,3)
- 17- 2c (1c following) cross down into a Fig8 round 3c, to finish (2,1,3)
- 25- 1c+3c R&L, finish facing 1cnrs (1M has no polite turn)
- 33- 1c set to 1cnr, to 2cnr, pulling Rsh back to sideline facing P ; turn RH 1½ to (2,1,3).

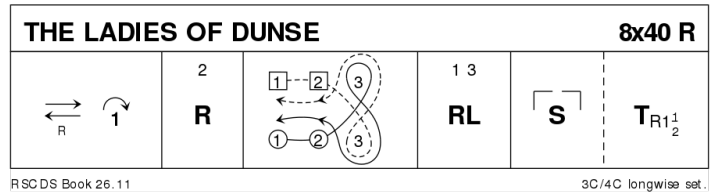

16 THE SWAN AND THE TAY S32 · 3/3L

Audrey Saunders: Scottish Country Dances for Perth 800 · Crib: E-cribs · Diagram: Keith Rose's Diagrams

- 1- 1c (in and down) Fig8 on own sides (give hands) (1,2,3)
- 9- 1c cross into Reels3{6} on opp. sides | 2c dance up as 1c face 1cnr
- 17- 1c+cnrs Pass&Turn, pass Rsh ; repeat with 2cnr, finish (2,1,3)
- 25- All set | cross RH ; chase ½ clw to (3,1,2)

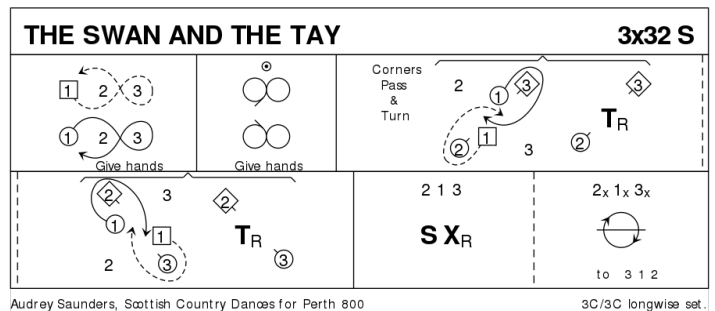

17 THE FIRST RAIN OF SPRING J32 · 3/3L

Wouter Joubert: RSCDS XLIX 4 · Crib: E-cribs · Diagram: Keith Rose's Diagrams

- 1-- 1c dance down below 3c | cast up 1 place ; dance up to 1pl facing out | 1c+2c ½ turn EH, 2c face out
- 9-- 2c+1c DbIFig8, 1c crossing up
- 17-20 1c+3c turn P RH ¾ and face P up/dn | set ;
- 21-28 (½ Celtic Reel) 1c+3c pass Rsh | "outers" chase ¼ way clw **while{2}** "inners" turn (no hands) ¾ Lsh to face same person ; repeat
- 29-32 1c+3c Turn P RH ¾ | all set

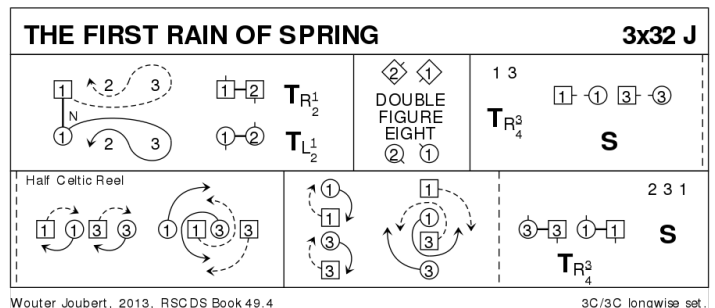

18 MAIRI'S WEDDING R40 · 3/4L

James B Cosh: *Twenty Two SCD · Crib: E-cribs · Diagram: Keith Rose's Diagrams*

- 1- 1c turn RH | cast (2c up) ; turn LH to face 1cnrs
- 9- 1c ½Reel4 with 1cnrs (pass P Lsh) ; Repeat with 2cnrs
- 17- Repeat with 3cnrs (1cnr person) ; Repeat with 4cnrs (2cnr person)
- 25- 1W+2c & 1M+3c Reels3 across, Lsh to 1cnr
- 33- 2c+1c+3c circle6 and back

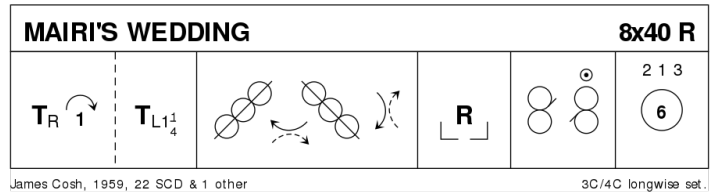

Note: Cosh explicitly tells 1c to pass Lsh in [9-24]; however the Rsh pass is quite common, and nicknamed »Mairi's Divorce«.

19 PROGRAMME ITEM – Extras

20 MACDONALD OF THE ISLES S32 · 3/3L

Derek Haynes: *Carnforth Collection of SC Dances 2 · Crib: E-cribs · Diagram: Keith Rose's Diagrams*

- 1- 2c diagonal Reel4 with 1cnrs, at end dance Lsh round P to face 2cnrs
- 9- 2c diagonal Reel4 with 2cnrs (2cnr loop by the R) (to 1,2,3)
- 17- 1c+2c+3c »snowball« G-Chain (1c begin, 2 bars per hand) (to 3,2x,1)
- 25- 3c+2c ½ R&L ; 3c ½ Fig8 R (3M up, 3W down) (2,3,1)

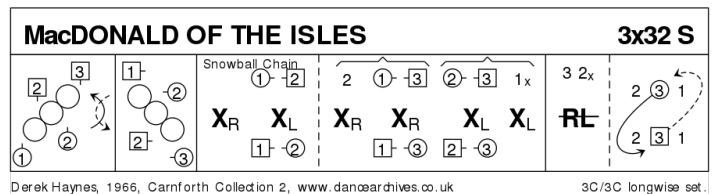

21 THE HAPPY MEETING J32 · 2/4L

RSCDS XXIX 9 · Crib: E-cribs · Diagram: Keith Rose's Diagrams

- 1- 1M+2W cross and dance ¾ Lsh round P, pass down/up Rsh, cast R round standing M/W to places
- 9- 1W+2M repeat (other shoulders)
- 17- 1c slip down the middle | set (1M starts L foot) ; slip to top | cast off (2c up)
- 25- 2c+1c A&R (all clap) ; turn P RH

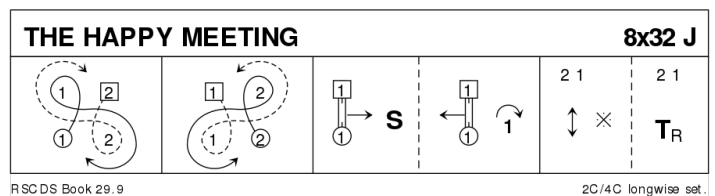

22 THE WIND ON THE HEATH

R32 · 3/4L

Iain Boyd: *Vive La Danse!* · Crib: *E-cribs* · Diagram: *Keith Rose's Diagrams*

- 1- 1c set | 1W (1M following) casts behind W side and crosses below 3c, 1W dances up behind M line while 1M dances up the middle, to (1x,2,3), 1M facing out
- 9- All C Rsh Reels3 on the sides. 1M finishes facing out.
- 17- 1M (1W following) dance behind W side and crosses below 3c, 1M dances up behind M line while 1W dances up the middle, to (1,2,3) | 1c set
- 25- 1c+2c Chain Progression: (turn P RH $\frac{3}{4}$ | 1M+2W turn LH $1\frac{1}{2}$ **while{4}** 1W+2M dance clw half round set and face P | turn P RH $\frac{3}{4}$) to (2,1,3)

