

# Leeds, York and N Humberside Joint Ball 17th November 2018

## 1 CURRIE MOUNTAIN R32 · 3/4L

Mary Pugh: New Brunswick Collection · Crib: E-cribs · Diagram: Keith Rose's Diagrams

- 1- 1c cross RH, cast off one (2c up) ;  
½Fig8 up round 2c (2,1,3)
- 9- 1c (start inwards) turn 3C EH ; 1c turn  
2C EH (2,1,3)
- 17- 1c+3c RHA ; 1c+2c LHA
- 25- 2c+1c+3c Reels3 on the sides, 1c  
giving Rsh to 3c (2,1,3)

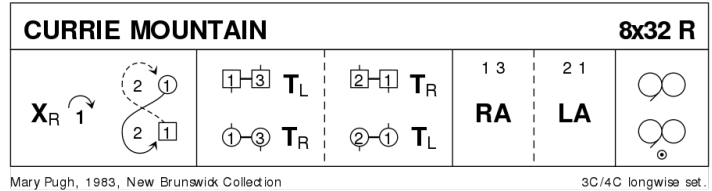

After the second turn the dancing couple continues the reel with bottom couple to change places.

## 2 THE CRANBERRY TART J32 · 3/4L

Terry Glasspool: Dances from the Seven Year Itch · Crib: E-cribs · Diagram: Keith Rose's Diagrams

- 1-16 *Fugue*: 1M set | cast (2M up) ; set |  
petronella to between 3c ;; set with 3c |  
advance with 3c ; retire with 3c |  
advance alone **while{16}** 1W waits {2}  
and then repeats 1M's [1-14], dancing  
with 2W and 2c, on [16] 1W pivots R to  
give Rsh to 2W
- 17- 1W with 1M following Reel3 across  
with 2c, finish (2,1,3)
- 25- Parallel Reels3 on own sides, 1c Rsh to 3c (2,1,3)

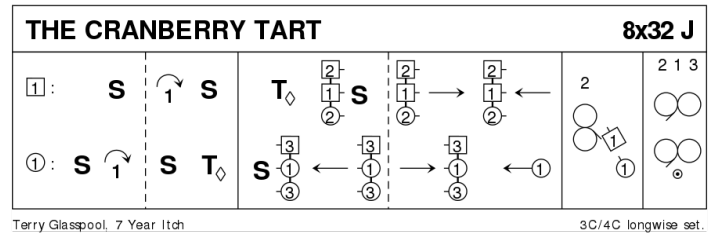

## 3 CHASING THE ECLIPSE S32 · 3/3L

Sandy Gallamore: The Highland Road Collection · Crib: SCDDDB Contributed Cribs & Diagrams · Diagram: Keith Rose's Diagrams

- 1-8 1C set, dance NH down the center +  
cast up to 2pl & cross to face 1cnr.
- 9-16 Reel 3 on sides - 1C pass 1cnr Rsh to  
begin.
- 17-24 1C+1cnr set , 1C spiral Rsh rnd ptrn  
to face 2cnr ; 1C+2cnr set , 1C spiral  
Rsh to face out 2pl own side.
- 25-32 All dance Chaperoned Chain  
Progression. End 3 1 2.

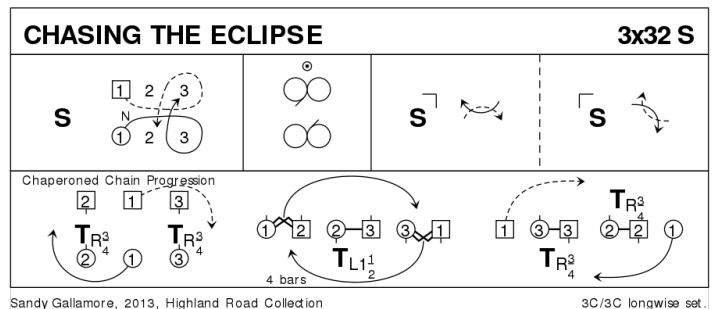

## 4 LADY SOPHIA LINDSAY R32 · 4/4L

Jean Attwood: Alexander Leaflets · Crib: E-cribs · Diagram: Keith Rose's Diagrams

On 2nd chord 3c+4c cross to (1,2,3x,4x)

- 1- 2c+3c RHA ; 2W & 3W with P following cast L round 1W & 4W »=2cnrs«
- 9- 1M+2c & 3c+4M RHA ; 1W+2c & 3c+4W LHA
- 17- 2c (on M side) & 3c (on W side) (still in tandem, W leading) opposing Reels3 on sidelines, Lsh to 4W/1W "=4cnr", to 2,1,4x,3x, middle Cs facing each other up/dn
- 25- 1c+4c set | cross RH on side ; set to P | cross RH (2,4,1x,3x)

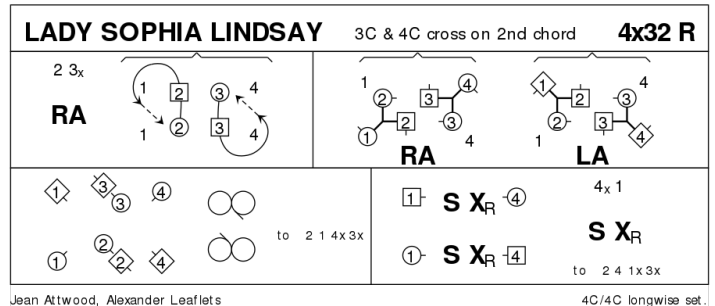

## 5 THE RAVEN'S DANCE J32 · 3/4L

Derek Haynes: Carnforth Collection of SC Dances 5 · Crib: E-cribs · Diagram: Keith Rose's Diagrams

- 1- 1c+2c DbIFig8 (1c cross down, 2c dance up, no cast), at the end 2c face out
- 9- Crossover Reels3 on the sides (1c cross down, 2c out and up), finish 1c side by side at top facing down, W on the R, 2c facing out
- 17- 1c (together) +2c Lead-change Reel3 across, Rsh to 2M. 2c finish in 1pl with 1c in between facing down
- 25- 1c dance down, cast up round 3c, lead up, cross between 2c and cast off (2,1,3)

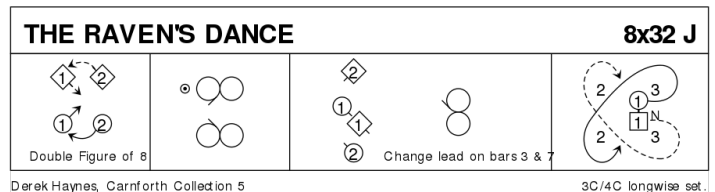

## 6 BEDRULE S32 · 3/4L

Betty Grant: RSCDS XXXIII 7 · Crib: E-cribs · Diagram: Keith Rose's Diagrams

- 1- 1W+2W & 1M+2M turn BH | open into circle4 L | 1c+2c turn P BH (on [8] 3c dance in) into
- 9- 1c+2c+3c Promenade, on [15-16] 1c cast off & 2c dance up (2,1,3)
- 17- 1c+3c RHA to sidelines (1W long turn) ; 2c+1c LHA, 1c finish facing down
- 25- 2c+1c+3c Rsh Reels3 on the sides (2,1,3)

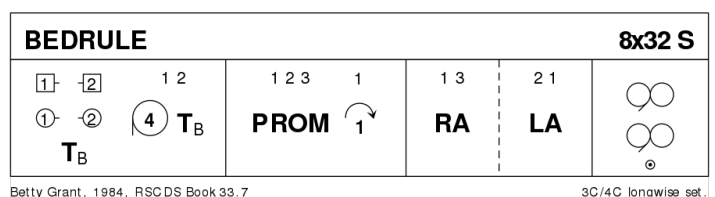

## 7 J. B. MILNE R32 · 3/4L

Hugh Foss: Angus Fitchet Scottish Dance Album · Crib: E-cribs · Diagram: Keith Rose's Diagrams

- 1– 1M+2W set advancing and turn RH ; 1W+2M repeat
- 9– 1c set advancing | turn BH and open upwards ; cast off one (2c up), Petronella Turn to: 1M between 3c and 1W between 2c
- 17– 1c set, turn  $\frac{3}{4}$  RH, set, turn  $\frac{3}{4}$  RH, **while**{8} 2c+3c pass RH on the sides, set, cross RH, set
- 25– 1c set, pass RH, cast R into 2pl, **while** {6} 2c+3c pass RH on the sides, set ; cross RH | all set. (2,1,3)

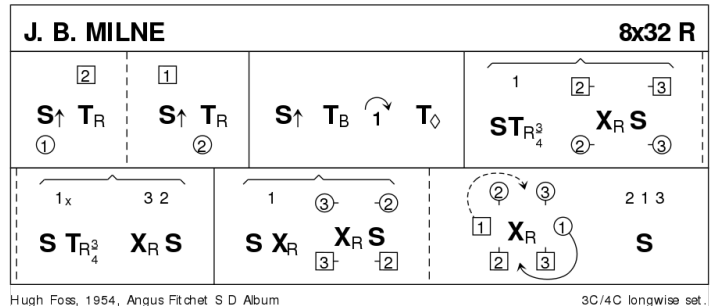

In 17-32, the corners traditionally set one bar to the person you just passed, then one bar to the next person to pass. In a variant for [19-24] 1c turns BH in PdB.

## 8 THE AVIATOR J32 · 3/4L

Carola Fischer: RSCDS LII 9 · Crib: SCDDDB Contributed Cribs & Diagrams · Diagram: Keith Rose's Diagrams

- 1- 8 1s lead down the middle; on bar 4, 1M crosses 1W in front of him. | 1W, followed by 1M, cast behind 4M and 3M to 2nd place.
- 9-16 1s, with W leading, half dolphin reel on 1st diagonal. | 1M dance 2nd half reel of 3 on 1st diagonal, while 1W and 3M turn LH.
- 17-24 1s, with M leading, half dolphin reel on 2nd diagonal. | 1W dance 2nd half reel of 3 on 2nd diagonal, while 1M and 3W turn LH.
- 25-32 In {6}, 1W cast up round 2M and across the top, 1M dance up round 2W, both cast behind 2W to 2nd place as 2s step up and face in; 2s,1s & 3s set.

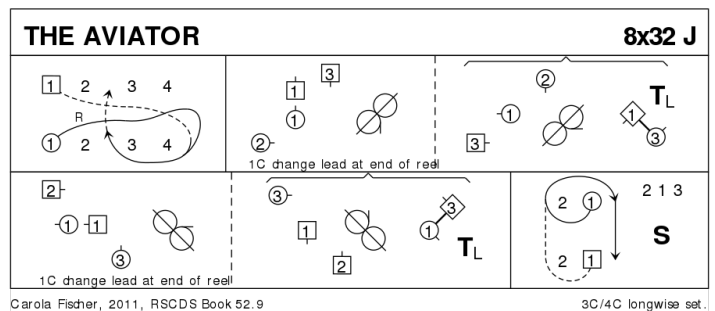

## 9 CULLA BAY S32 · 4S

Ann Dix: RSCDS XLI 2 · Crib: E-cribs · Diagram: Keith Rose's Diagrams

- 1– 1c+3c turn RH  $\frac{1}{2}$  with person opposite, face that person | twirl R and into opposite place ; 2c+4c repeat this and face in **while**{4} 1c+3c (W leading) chase  $\frac{1}{4}$  clw | curve into centre and swivel R to face out (1c facing 4pl and 3c facing 2pl)
- 9– Parallel Reels4 across
- 17– 2c+1c & 3c+4c circle4 L ; face other couple and set |  $\frac{1}{2}$  RHA, flowing into
- 25– 2c+4c LHA in the middle ; dance out passing same sex standing dancer on the side Rsh, and chase R (M leading) to 1pl/3pl (to 2,3,4,1).

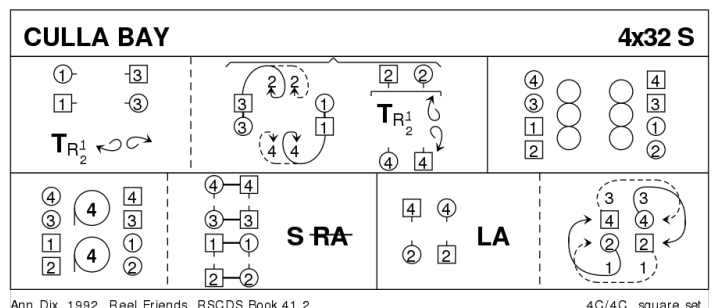

## 10 INTERVAL

### 11 STAIRCASE IN STYRIA R40 · 5/5L

Margaret Gray: CD booklet of *The Sunday Class Dance Book 2* · Crib: *E-cribs* · Diagram: *Keith Rose's Diagrams*

- 1– 1c+2M & 3c+4M RHA 1¼, 1c & 3c finishing in middle facing down, other cpls in own place ; 1c+2W & 3c+4W LHA, finish facing down
- 9– 1c+4M & 3c+5M RHA same way ; 1c+4W & 3c+5W LHA, 1W & 3W face out on own side with P behind
- 17– 1c & 3c (W leading) cast up 1 place, cross, cast up on M side to original places the W looping R
- 25– 1c cross | cast 1 (2c up) ; 1c followed by 3c dance up & cast to (2,3,1x,4,5)
- 33– 1c cross | cast 1 (4c up) ; 1c followed by 5c dance up & cast to (2,3,4,5,1)

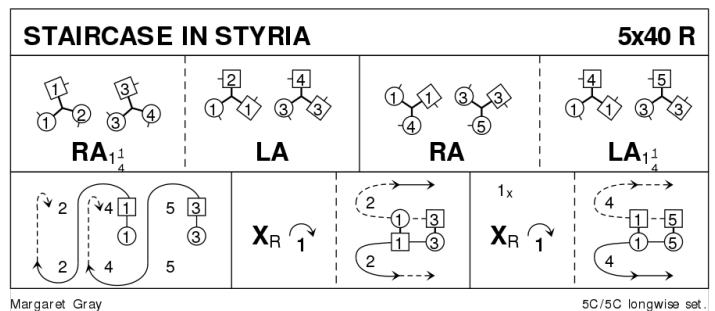

### 12 MONICA'S WAY J32 · 4/4L

Gail Sibley: *RSCDS XLVIII 4* · Crib: *MiniCribs* · Diagram: *Keith Rose's Diagrams*

3s & 4s start on opp sides

- 1-8 1s/4s cross RH as 2s/3s set, 1s+2s & 4s+3s dance 3/4 double Fig of 8 (1s/4s casting down/up to start). 2 1(4)(3)
- 9-16 1s+4s Set & Rotate:  
Set, Rotate singly & dance on 1 place clockwise, change places RH on sides & dance on 1 place to own sides.  
2(4)1(3)
- 17-20 1L+4M also 4L+1M (Lady leads) 1/2 alternating tandem diag RSh reel of 4 with 3L+2L & passing LSh curve to right to next corner (same end)
- 21-24 4M+1L also 1M+4L (Man leads) 1/2 alternating tandem diag RSh reel of 4 with 3M+2M & pass RSh to end 3(1)4(2)
- 25-32 1s & 4s cross passing RSh & loop into places, all Adv+Ret. 3 1(4)(2)

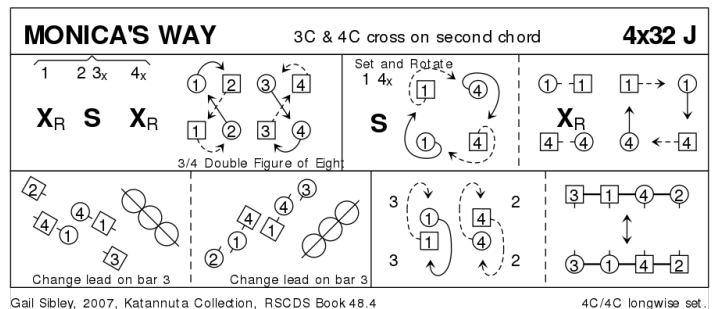

### 13 SCARBOROUGH CASTLE S32 · 3/4L

Ann Dix: *The Leeds Golden Collection* · Crib: *E-cribs* · Diagram: *Keith Rose's Diagrams*

- 1– 1c+2c the Knot, 1c turning on to face 1cnr
- 9– Cnrs pass and turn (with 1cnrs, pass Rsh, with 2cnrs) (to 2,1,3)
- 17– All set | cross RH ; Circle6 ¾ clw into facing lines across
- 25– All set | cross up/down LH ; Circle6 ¾ cclw (2,1,3)

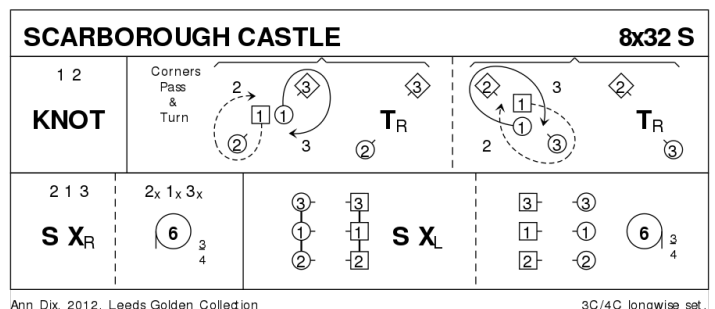

## 14 BURNIEBOOZLE R32 · 3/4L

David G Queen: Southport Book Volume 1 · Crib: E-cribs · Diagram: Keith Rose's Diagrams

- 1- 1c set, cast (2c up) ; turn LH 1½ and face out (2,1x,3)  
 9- Reels3 on the sides (Lsh to 2cnr), at end 1c turn RH to face 1cnrs  
 17-32 »Dance to Each Corner and Set«  
 («Free« cnrs set diagonally **while{2}** centre dancers change place Rsh with the facing cnr, who in the centre pass Rsh to face next cnr on R. Repeat this five times, on alternating diagonals) ;  
 1c turn RH 1½ to 2pl **while{4}** 3c+2c ½ R&L starting along the sides.(2,1,3)

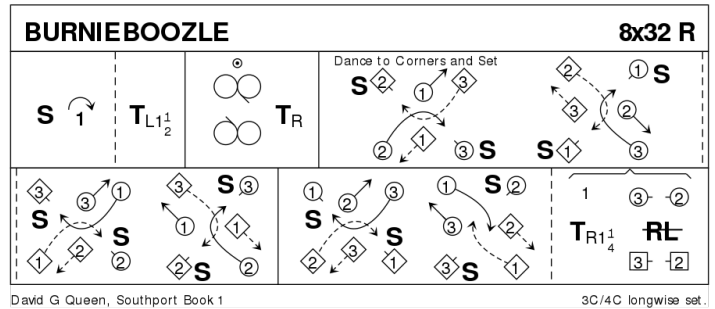

## 15 THE ZOOLOGIST J32 · 3/4L

Duncan Brown: RSCDS XLVI 12 · Crib: E-cribs · Diagram: Keith Rose's Diagrams

- 1- 1c cross down RH (2c up) and cast R to between end cpl facing 4cnr ; ½ Lsh Reels3 across, 1c face 1cnr (pos)  
 9- ½ Reel4 on 1diag, 1c pass Rsh and face 2cnr pos. ; ½ Reel4 on 2diag, 1c finish BtoB in middle facing opposite side (3, 1x\_mid, 2)  
 17- DTr, 1c finish Rsh to Rsh facing opposite side  
 25- 3c+1M & 1W+2c LHA finish as started ; 1M leading 3c & 1W leading 2c dance to 1cnr {1}, 4cnr {2}, 2pl own side {1}, to finish (2,1,3). This is like the »Snake Pass«, but with sharp angles, forming the letter »Z« for Zoologist (from a note by the deviser).

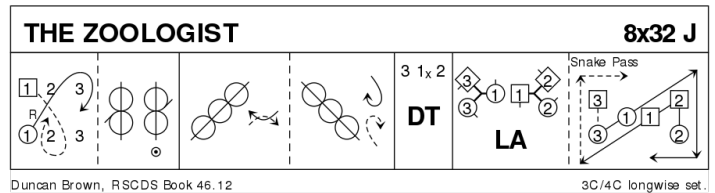

## 16 MACDONALD OF KEPPOCH M128 · 4S

Chris Ronald: RSCDS XLIX 11 · Crib: SCDDDB Contributed Cribs & Diagrams · Diagram: Keith Rose's Diagrams

- 1-- 1c+3c 6 bars of R&L to BtoB facing sides | all set  
 9-- Parallel Reels4 across, 1c+3c finish half way the last left pass, in a line up and down the set  
 17-- 1c+3c Lsh Reel4, 1W+3W pass Rsh in middle to start, to finish in original places  
 25-- All set to P | all 1¼ turn P RH | all ¼ cclw chase in promhold (2,3,4,1)

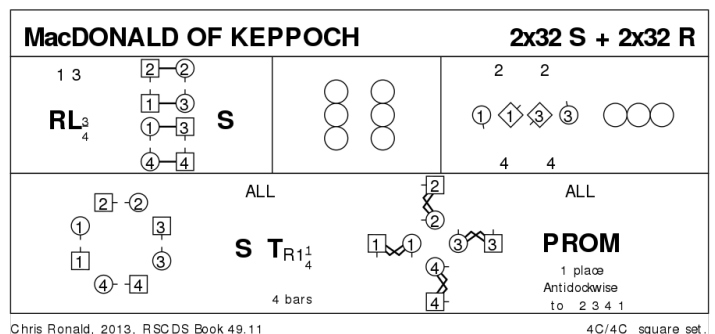

The first two turns are in Strathspey time, the second two are in Reel time.

## 17 MACLEOD'S FANCY J32 · 4/4L

John Drewry: RSCDS XXXIII 3 · Crib: E-cribs · Diagram: Keith Rose's Diagrams

- 1- 1c+4c set facing diagonally | 1W+4M cast R round own sideline and meet with  $\frac{3}{4}$  RH turn in the middle, to places **while{6}** 1M+4W make that turn and cast R round own sideline to places
- 9- All dance Reels4 on the sides to finish (1,2,3,4) facing up/dn
- 17- Middles (2c+3c) turn ends RH  $\frac{1}{2}$  way to form a St Andrew's Cross (1c+4c retain RH and give LHA in the middle) | all set ; continue turns once round RH, at the end 1c+4c pass Rsh on own side to end (2,4,1,3) (1M+4W with polite turn)
- 25- (Middle couples solo:) 4c+1c set, Women cross NHJ and face ends **while{2}** Men cross over outside them and turn inwards to join P ; 4c(1c) lead up RH (lead down LH) between 2c(3c), cross and cast to 2pl(3pl) (2,4,1,3)

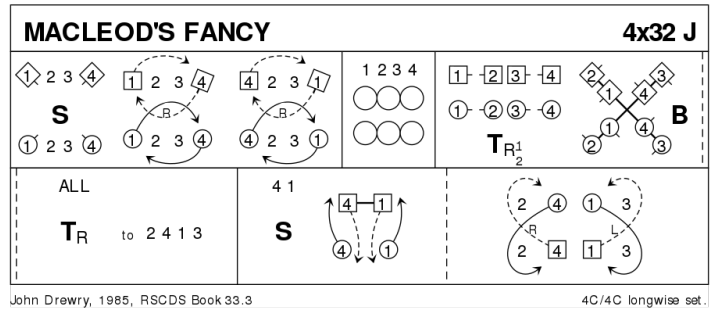

## 18 MISS CATHERINE ANN S32 · 3/3L

David G Queen: Queen Collection of SCD Vol 1 · Crib: MiniCribs · Diagram: Keith Rose's Diagrams

- 1-8 1L+2L Set+Link **while** 1M+2M Reverse Set+Link, 1s dance 1/2 Fig of 8 round 2s
- 9-16 1M+3L Set+Link **while** 1L+3M Reverse Set+Link, 1s dance 1/2 Fig of 8 round 3s
- 17-24 2s+3s+1s petronella turn into centre & set to partners, 1/2 turn 2H & petronella turn back to sides for...
- 25-32 2s+3s+1s circle 6H round & back

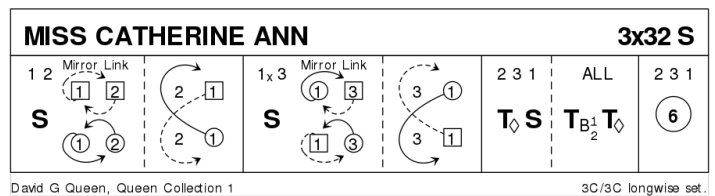

## 19 THE IRISH ROVER R32 · 3/4L

James B Cosh: Twenty Two SCD · Crib: E-cribs · Diagram: Keith Rose's Diagrams

- 1- 1c lead through 3c (2c up) and cast up ; 1M+3c and 1W+2c RHA, finish facing 1cnrs.
- 9- 1c+1cnrs  $\frac{1}{2}$ Reel4, pass Lsh ;  $\frac{1}{2}$ Reel4 with 2cnrs, fast  $\frac{3}{4}$  LH turn in the centre
- 17- 1W+3c (at top) & 1M+2c Reels3 across (Lsh to 1cnr pos), (to 3x,1,2x)
- 25- diagonal R&L (1M down,1W up) (2,1,3)

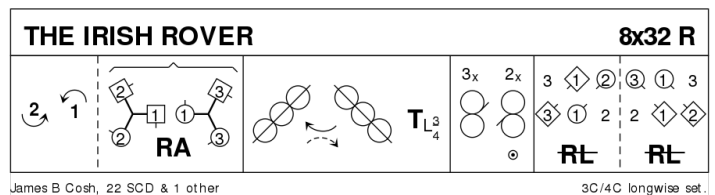

## 20 EXTRAS

## 21 CITY OF BELFAST S32 · 3/3L

Lucy Mulholland: RSCDS XLVIII 6 · Crib: E-cribs · Diagram: Keith Rose's Diagrams

- 1- 1c ½ Fig8 round 2c ; 1c turn 2c EH 1¼ into line across, 1c in the middle
- 9- 1c+2c Reel4, finish 2c in 1pl and 1c (last pass is Lsh) facing 1cnr
- 17- 1c set to 1cnr | set to 2cnr, dancing R into sideline (2,1x,3) ; All set | 1c cross RH
- 25- 1c+3c Espagnole (2,3,1)

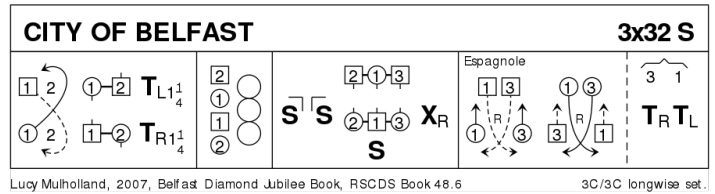

Espagnole: both W lead RHJ to M side, cross and cast back to exchanged places while Men cross to W side, lead RHJ back to M side crossing to exchanged places ; all turn P EH (2,1)

## 22 BROADFORD BAY R32 · 3/4L

Anne Grant: The Leaflet Dances with Music · Crib: E-cribs · Diagram: Keith Rose's Diagrams

- 1- 1c (leading)+2c (dance up to begin), dance between 3c, cast up and dance to top, and 1c cast off (to 2,1,3)
- 9- 2c+1c+3c G-Chain (2c cross to start), finish 2M & 1W facing out (2,1,3)
- 17- 2W+1M turn RH 1½ while{4} 2M+1W chase ½ round cclw ; 2W+1M chase ½ round clw to 1W/2M places while{4} 2M+1W turn LH 1¼ to face P on 2diagonal
- 25- 2c+1c diagonal Reel4 (to 2,1,3)

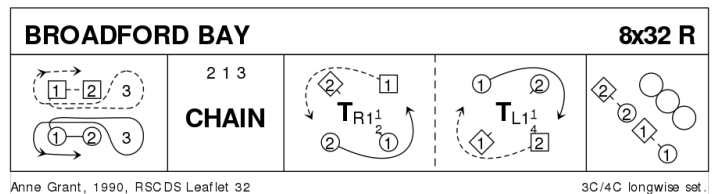

## 23 LES REMPARTS DE SÉVILLE J32 · 3/4L

Aliénor Latour: RSCDS L 2 · Crib: E-cribs · Diagram: Keith Rose's Diagrams

- 1-- 1c set | cast off (2c up) ; 1c ½Fig8, Lsh to 1cnr
- 9-- 1c turn LH to face 1cnrs | 6 bars of set H&G, into lines across
- 17-- S&Link3 ; all set | all cross RH
- 25-- Circle6 and back (2,1,3)

