

Leeds York Joint Ball 16 November 2019

1 THE SHETLAND SHEPHERDESS J32 · 3/4L

Ron Wallace: *A Third Book of Graded Scottish Country Dances* · Crib: *E-cribs* · Diagram: *Keith Rose's Diagrams*

- 1-- 1c dance between 2c and cast up to place ; dance ½ Fig8 round 2c (1x,2,3)
- 9-- 1c cross down into mirror Reels3 on own side, 2c starting out and up (1,2,3)
- 17-- 1c (start inwards) change place with 2c EH and face out | 1c turn 3c EH to face up in the middle ; 1c dance to top and cast off (2,1,3)
- 25-- All A&R and clap on last beat of [28] ; All turn P RH (2,1,3)

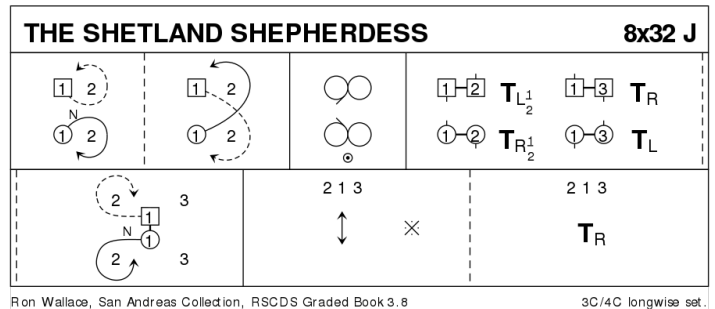

2 BEESWING R32 · 3/4L

Roy Goldring: *Graded and Social Dances 2 - 23 Dances* · Crib: *E-cribs* · Diagram: *Keith Rose's Diagrams*

- 1– 1c dance in to touch hands, cast to 3pl (2c up) , dance up to face own side for
- 9– DTr (to 2,1,3)
- 17– 1c turn RH ; turn LH
- 25– Teapots R ; and L (2,1,3)

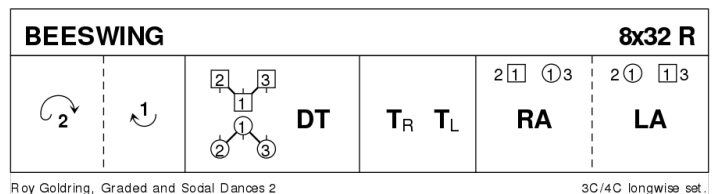

3 SCARBOROUGH CASTLE S32 · 3/4L

Ann Dix: *The Leeds Golden Collection* · Crib: *E-cribs* · Diagram: *Keith Rose's Diagrams*

- 1– 1c+2c the Knot, 1c turning on to face 1cnr
- 9– Cnrs pass and turn (with 1cnrs, pass Rsh, with 2cnrs) (to 2,1,3)
- 17– All set | cross RH ; Circle6 ¾ clw into facing lines across
- 25– All set | cross up/down LH ; Circle6 ¾ cclw (2,1,3)

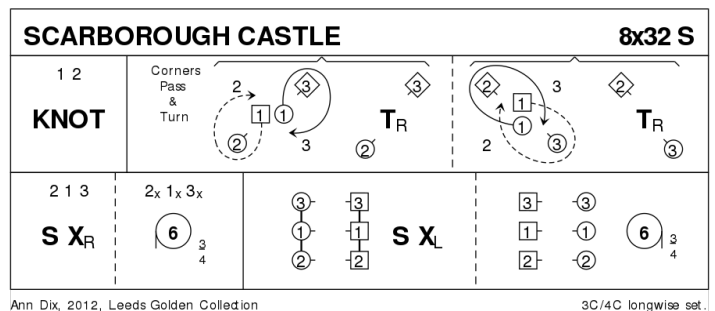

4 THE CHEQUERED COURT J32 · 3/4L

Duncan Brown: RSCDS XLII 3 · Crib: E-cribs · Diagram: Keith Rose's Diagrams

- 1- 1c cross RH | cast off (2c up) ; ½ Fig8 across to the R (1M up, 1W down) to face 1cnr
- 9- 1c+1cnrs pass and turn, at end 1c swivels R to be BtoB facing 4cnr ; 1c+4cnrs pass and turn, 1c swivels R to finish BtoB facing own side for DTr, 1c finish between end couple facing own side
- 17- DTr, 1c finish between end couple facing own side
- 25- Reels3{6} across (Rsh to 4cnr) | 1c cross RH (2,1,3)

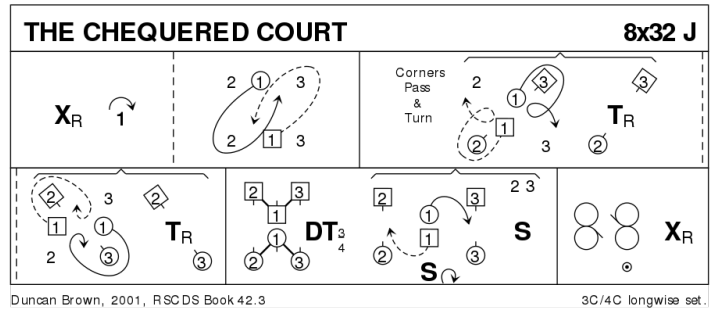

5 BROADFORD BAY R32 · 3/4L

Anne Grant: The Leaflet Dances with Music · Crib: E-cribs · Diagram: Keith Rose's Diagrams

- 1- 1c (leading)+2c (dance up to begin), dance between 3c, cast up and dance to top, and 1c cast off (to 2,1,3)
- 9- 2c+1c+3c G-Chain (2c cross to start), finish 2M & 1W facing out (2,1,3)
- 17- 2W+1M turn RH 1½ **while{4}** 2M+1W chase ½ round cclw ; 2W+1M chase ½ round clw to 1W/2M places **while{4}** 2M+1W turn LH 1¼ to face P on 2diagonal
- 25- 2c+1c diagonal Reel4 (to 2,1,3)

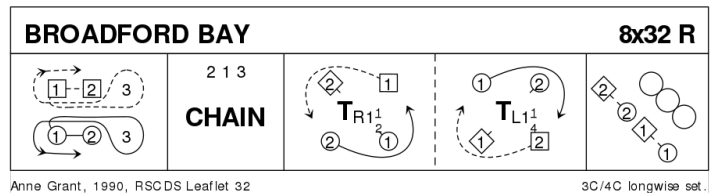

6 MISS CATHERINE ANN S32 · 3/3L

David G Queen: Queen Collection of SCD Vol 1 · Crib: MiniCribs · Diagram: Keith Rose's Diagrams

- 1-8 1L+2L Set+Link **while** 1M+2M Reverse Set+Link, 1s dance 1/2 Fig of 8 round 2s
- 9-16 1M+3L Set+Link **while** 1L+3M Reverse Set+Link, 1s dance 1/2 Fig of 8 round 3s
- 17-24 2s+3s+1s petronella turn into centre & set to partners, 1/2 turn 2H & petronella turn back to sides for...
- 25-32 2s+3s+1s circle 6H round & back

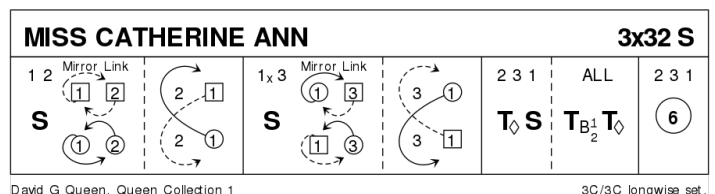

7 A CAPITAL JIG J32 · 3/4L

Tine E MacKay: Magazine Dances 2005-2009 · Crib: E-cribs · Diagram: Keith Rose's Diagrams

- 1- 1c+2c Set&Rotate, finish 1c facing 2c (2,1,3)
- 9- Rsh Reels3 on the sides
- 17- 1c set | turn $\frac{3}{4}$ RH ; 2c+1W & 1M+3c LHA (to 2,1x,3)
- 25- 1c set | turn $\frac{3}{4}$ RH ; 2c+1M & 1W+3c LHA (2,1,3)

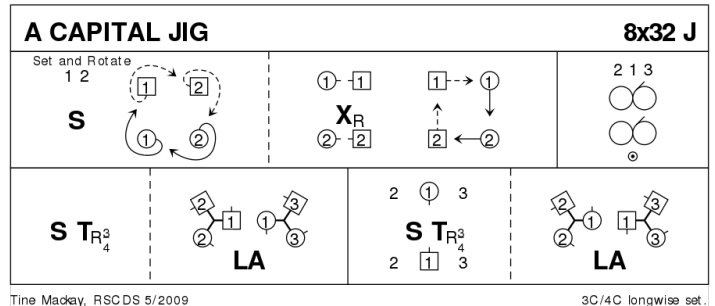

8 RUBY WILKINSON'S FAREWELL TO CRANSHAWS S32 · 4/4L

Alasdair Brown: RSCDS LII 6 · Crib: MiniCribs · Diagram: Keith Rose's Diagrams

2 chords - 2nd chord 3s+4s cross to opp sides

- 1-8 1s+4s set, cast down/up to 2nd/3rd places (2s+3s step up/down bars 3-4). 1s+4s turn 1/2 LH & dance 1/2 LH across to 1M facing 3L, 1L+3M, 4M+2L, 4L+2M
- 9-16 4s+1s dance diagonal interlocking reels of 4 with corner positions (LH across 1/2 way in middle) **while** 2s (in 1st place) & 3s (in 4th place) dance reels of 4 across. End with 4s+1s facing each other, NHJ with partner, (4s face down, 1s face up)
- 17-24 4s+1s Set+Link & dance circle 4H round to Left
- 25-32 2s+4s also 1s+3s dance Poussette 2 4 (1) (3)

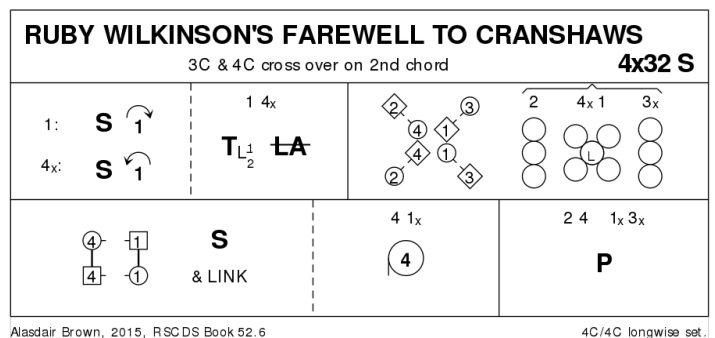

9 PELORUS JACK J32 · 3/4L

Barry Skelton: RSCDS XLI 1 · Crib: E-cribs · Diagram: Keith Rose's Diagrams

- 1- 1c cross RH, cast (2c up) ; 1c+3c RHA, finish 1M facing 1cncr, 1W behind him
- 9- 1c in tandem +1cnrs $\frac{1}{2}$ diagonal Reel3, Rsh to 3W (1M & 1W loop R singly for lead change, so 1W now leads P) ; $\frac{1}{2}$ diagonal Reel3, Rsh to 2W (+ lead change)
- 17- Continue pattern twice
- 25- 2c+1c LHA ; 1c turn LH $\frac{1}{2}$ | all set (2,1,3)

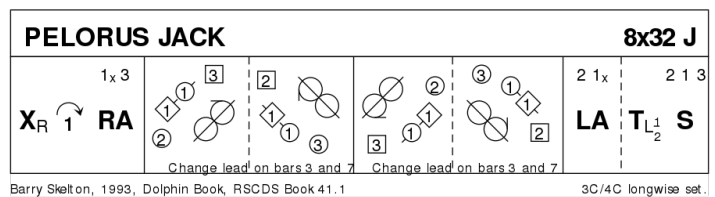

10 THE MONTGOMERIES' RANT

R32 · 3/4L

Castle Menzies (18C): RSCDS X 1 · Crib: E-cribs · Diagram: Keith Rose's Diagrams

- 1– 1c cross RH | cast off (2c up) ; cross LH | cast L (W up, M down)
- 9– 2c+1W & 1M+3c Rsh Reels3 across
- 17– 1c NHJ set to 2W (swivel ½ inwards), set to 3M (veer L together), set to 3W (swivel ½ inwards), set to 2M (and face own 2cnr)
- 25– Reels3{6} on the sides, Rsh to 2cnr | 1c cross RH to 2pl

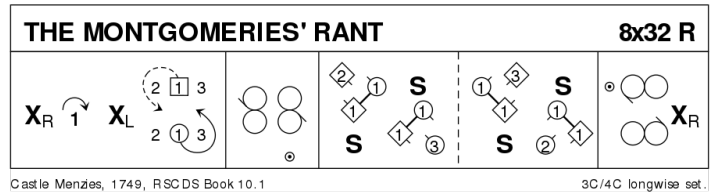

11 PROGRAMME ITEM – Interval

12 BRATACH BANA R32 · 3/4L

John Drewry: Bon Accord Book of Scottish Country Dances · Crib: E-cribs · Diagram: Keith Rose's Diagrams

- 1– 1c turn RH | cast off (2c up) ; ½ Fig8 to R around 1cnr (to 2,1x,3)
- 9– ½ Reel3 on sides (Rsh to 2cnr) ; ½ Reel3 across (Lsh to 3cnr position), finish on sides (3x,1,2x)
- 17– 1c turn ¾ LH, Turn 1cnr person (3cnr position) RH ; pass Rsh, turn 2cnr person (4cnr position) ¾ RH to promhold (cnr on the right)
- 25– These pairs change places Rsh | drop left hand and turn RH ½ to sidelines ; half diagonal R&L (1st diagonal direction)

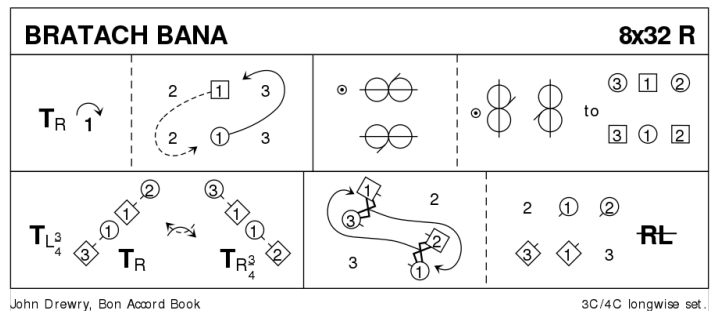

Note on [27-28]: originally 2 PdB. modified by Drewry to SkCh. O. Otto says best variant is corners in PdB, 1c in SkCh

13 RODNEY'S RANT J32 · 3/4L

Ann Dix: QE Diamond Jubilee Dances · Crib: E-cribs · Diagram: Keith Rose's Diagrams

- 1– 1c set | cast (2c up) ; dance between 3c and cast up (2,1,3)
- 9– Diagonal R&L (3x,1,2x)
- 17– All S&Link3 into lines across ; repeat (2,1x,3)
- 25– 1c ½ Fig8 L (W up, M down) ; All turn P RH (2,1,3)

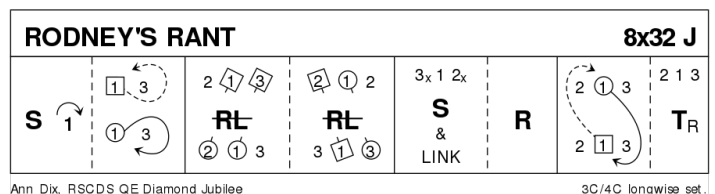

14 MACDONALD OF KEPPOCH M128 · 4S

Chris Ronald: RSCDS XLIX 11 · Crib: E-cribs · Diagram: Keith Rose's Diagrams

- 1-- 1c+3c $\frac{3}{4}$ R&L to BtoB facing sides | all set
- 9-- Parallel Reels4 across, 1c+3c finish half way the last left pass, in a line up and down the set
- 17-- 1c+3c Lsh Reel4, 1W+3W pass Rsh in middle to start, to finish in original places
- 25-- All set to P | all turn P RH $1\frac{1}{4}$ | all in promhold chase cclw $\frac{1}{4}$ (2,3,4,1)

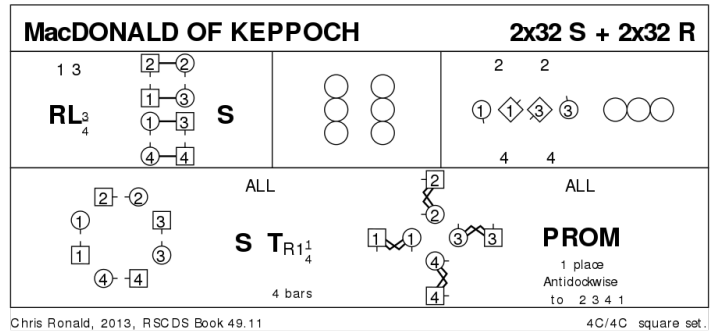

The first two turns are in Strathspey time, the second two are in Reel time.

15 MAJOR IAN STEWART J32 · 3/4L

John Drewry: RSCDS XXXV 4 · Crib: E-cribs · Diagram: Keith Rose's Diagrams

- 1-- 1c+2c turn RH $\frac{1}{2}$ into | $\frac{1}{2}$ RHA into ; 2c+1c turn RH, 2c finish facing out (2,1,3)
- 9-- Opposing Reels3 on own sides (1c inwards, Rsh to 4cnr) 1c finish facing 1cnr, 2c+3c finish with loops
- 17-- SetH&G to (2,1,3)
- 25-- Circle6 L {3}, cross R foot over L and chase back cclw to (2,1,3)

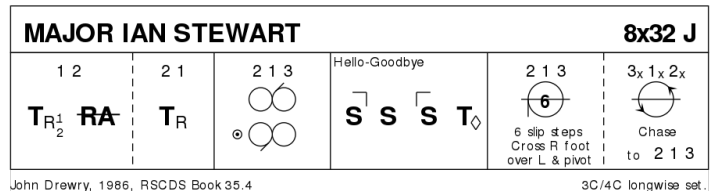

16 THE AVIATOR J32 · 3/4L

Carola Fischer: RSCDS LII 9 · Crib: E-cribs · Diagram: Keith Rose's Diagrams

- 1-- 1c lead down (2c up), on [4] 1W crosses in front and, 1M following, casts up (round any standing M), to finish 1c in 2pl facing 3W
- 9-- 3W+1c+2M Rsh lead-change diag. Reel3 ; 1M dancing the full reel, **while for [13-16]** 1W turns 3M LH to finish behind 1M, both on midline facing up
- 17-- 2W+1c+3M Rsh lead-change diag. Reel3 ; 1W dancing the full reel, **while for [21-24]** 1M turns 3W LH to finish 1c in 2plx, 1W facing out
- 25-- 1c dance up (1W Rsh to 2M, 1M Rsh to 2W) | 1c dance Rsh round 2W to 2pl | All set.

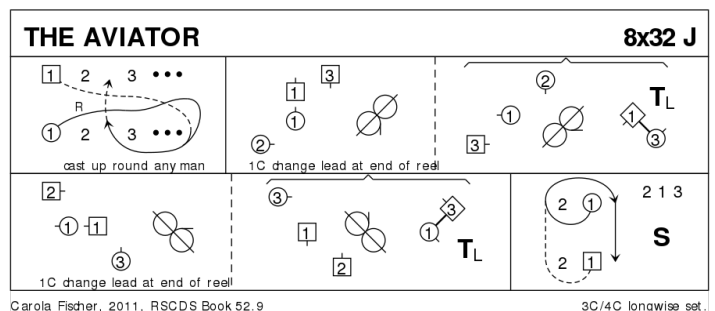

17 MISS OGILVIE'S FANCY S32 · 3/4L

William (18C) Campbell: RSCDS XX 8 · Crib: E-cribs · Diagram: Keith Rose's Diagrams

- 1- 1c+2c Poussette (1,2,3)
- 9- 1c lead down the middle and up | cast off (2c up)
- 17- 1c+3c Circle4 and back
- 25- 2c+1c R&L

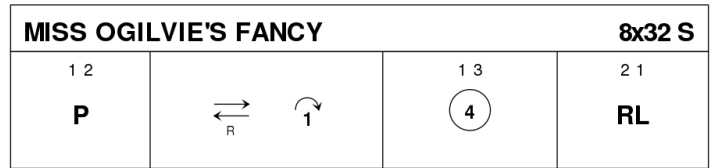

William Campbell, 1789, RSCDS Book 20.8

3C/4C longwise set.

18 MACLEOD'S FANCY J32 · 4/4L

John Drewry: RSCDS XXXIII 3 · Crib: E-cribs · Diagram: Keith Rose's Diagrams

- 1- 1c+4c set facing diagonally | 1W+4M cast R round own sideline and meet with $\frac{3}{4}$ RH turn in the middle, to places **while{6}** 1M+4W make that turn and cast R round own sideline to places
- 9- All dance Reels4 on the sides to finish (1,2,3,4) facing up/dn
- 17- Middles (2c+3c) turn ends RH $\frac{1}{2}$ way to form a St Andrew's Cross (1c+4c retain RH and give LHA in the middle) | all set ; continue turns once round RH, at the end 1c+4c pass Rsh on own side to end (2,4,1,3) (1M+4W with polite turn)
- 25- (Middle couples solo:) 4c+1c set, Women cross NHJ and face ends **while{2}** Men cross over outside them and turn inwards to join P ; 4c(1c) lead up RH (lead down LH) between 2c(3c), cross and cast to 2pl(3pl) (2,4,1,3)

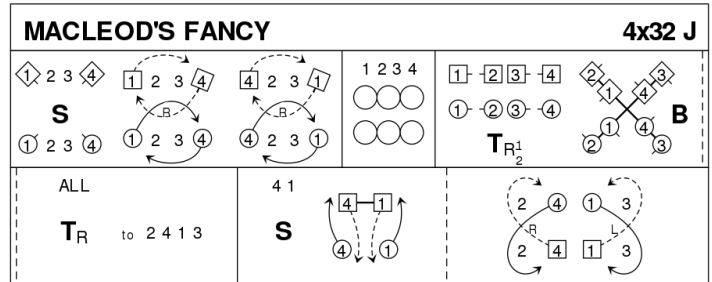

John Drewry, 1985, RSCDS Book 33.3

4C/4C longwise set.

19 STAIRCASE IN STYRIA R40 · 5/5L

Margaret Gray: CD booklet of The Sunday Class Dance Book 2 · Crib: E-cribs · Diagram: Keith Rose's Diagrams

- 1- 1c+2M & 3c+4M RHA $1\frac{1}{4}$, 1c & 3c finishing in middle facing down, other cpls in own place ; 1c+2W & 3c+4W LHA, finish facing down
- 9- 1c+4M & 3c+5M RHA same way ; 1c+4W & 3c+5W LHA, 1W & 3W face out on own side with P behind
- 17- 1c & 3c (W leading) cast up 1 place, cross, cast up on M side to original places the W looping R
- 25- 1c cross | cast 1 (2c up) ; 1c followed by 3c dance up & cast to (2,3,1x,4,5)
- 33- 1c cross | cast 1 (4c up) ; 1c followed by 5c dance up & cast to (2,3,4,5,1)

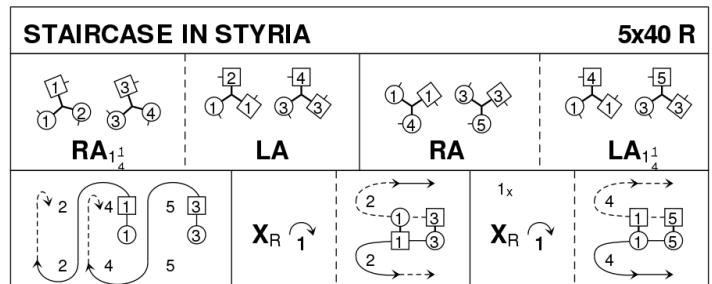

Margaret Gray, CD booklet of The Sunday Class Book 2

5C/5C longwise set.

20 TRIPLE HAPPINESS S32 · 3/3L

Yoshiki Oyama: RSCDS LII 10 · Crib: E-cribs · Diagram: Keith Rose's Diagrams

- 1-- 1c A&R{1+1} taking (or shaking) RH briefly | turn LH ½ facing down ; cross LH between 2c and cast up to 1pl
- 9-- 1c+2c The Knot, 1c finish facing 1cnrs (2,1,3)
- 17-- Corners Pass and Turn BH (2,1,3)
- 25-- All chase clw ½ ; turn BH ½, face each other | cast R to exchanged places (3,1,2)

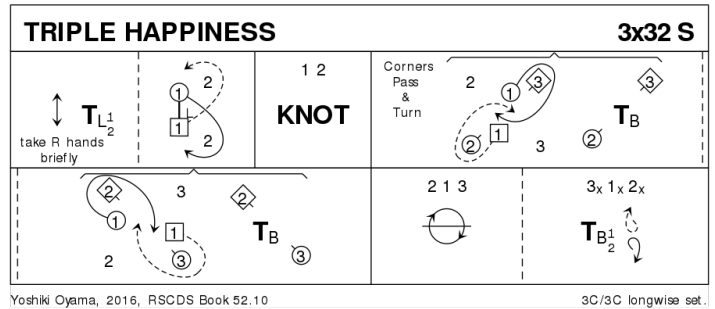

21 THE REEL OF THE ROYAL SCOTS R32 · 3/4L

Roy Goldring: The Leaflet Dances with Music · Crib: E-cribs · Diagram: Keith Rose's Diagrams

- 1-- 1W+2W (1M+2M) turn LH (RH) ½, finishing 1c BtoB in 2pl | All set as in DTr ; 1W+3W (1M+3M) turn RH (LH) ½ | 2c+3c+1c set as in DTr
- 9-- 1c followed by 3c dance up between 2c, cast off ; dance NHJ down through 3pl, cast up to face 1cnrs, 3c looping into 3pl
- 17-- 1c turn 1cnrs RH, pass Rsh (cnrs dance for {4}) ; turn 2cnrs RH (same), and cross Rsh to (2,1,3)
- 25-- All circle6 and back

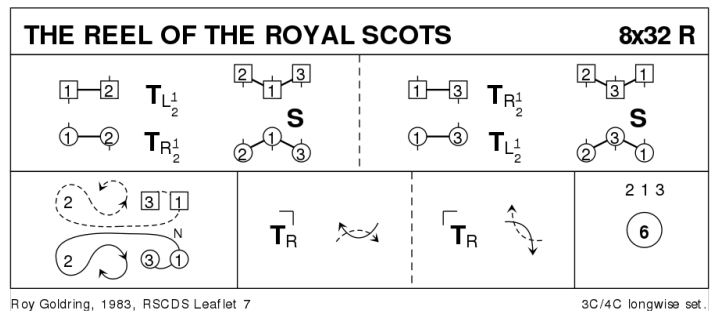

22 SCOTT MEIKLE R32 · 4/4L

Alice McLean: RSCDS XLVI 3 · Crib: E-cribs · Diagram: Keith Rose's Diagrams

- 1-- 1c cross RH | cast (2c up) ; ½ Fig8 up (2,1,3,4)
- 9-- 1c+3c RHA, LHA (2,1,3,4)
- 17-- Lsh opposing Reels3 across: (1W+3W behind dancing as one) with 2c and (3M+1M behind) with 4c (to 2,3,1,4)
- 25-- 1c+4c ½ R&L ; turn RH 1½ (2,3,4,1)

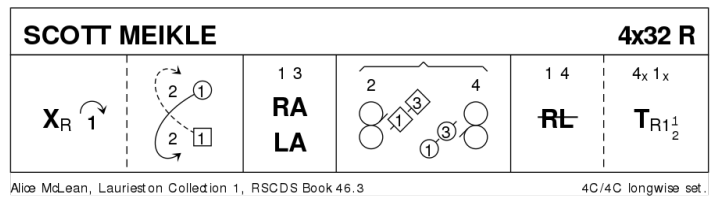

23 WEST'S HORNPIPE R32 · 4/4L

Five Traditional Scottish Country Dances for 1965 · Crib: E-cribs · Diagram: Keith Rose's Diagrams

- 1-- 1c+2c+3c mirror Reels3 on opposite sides (1c cross down, 2c out and up)
- 9-- Repeat, 1c now to own sides
- 17-- 1c lead down ; and up to top to face 2c from the middle diagonally
- 25-- 1c set to 2c | dance to the bottom (2c+3c+4c up) and turn inwards into ; 4c+1c Circle4 L.

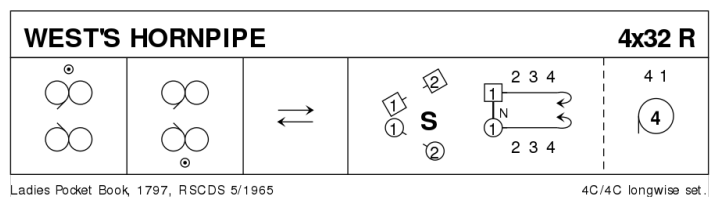

24 THE SWAN AND THE TAY S32 · 3/3L

Audrey Saunders: Scottish Country Dances for Perth 800 · Crib: E-cribs · Diagram: Keith Rose's Diagrams

- 1- 1c (in and down) Fig8 on own sides (give hands) (1,2,3)
- 9- 1c cross into Reels3{6} on opp. sides | 2c dance up as 1c face 1cnr
- 17- 1c+cnrs Pass&Turn, pass Rsh ; repeat with 2cnr, finish (2,1,3)
- 25- All set | cross RH ; chase ½ clw to (3,1,2)

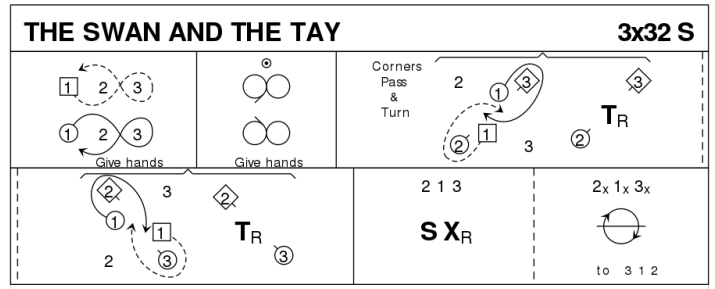

Audrey Saunders, Scottish Country Dances for Perth 800

3C/3C longwise set.