

# White Rose Festival Evening Dance 2018

## 1 MISS ALLIE ANDERSON J32 · 3/4L

Mina Corson: *The Leaflet Dances with Music* · Crib: *Eric's E-cribs* · Diagram: *Keith Rose's Diagrams*

- 1- All clap, 1W+2W+3W dance Rsh once round P to face down with him RHJ ; All lead down the middle
- 9- All M turn P under R arm and lead up to (1x,2x,3x) ; All set, ½ RH turn into
- 17- 1c+2c+3c Promenade (1,2,3)
- 25- 1c+2W RHA, 1M finishing 2pl own side (2M up on [3-4]) ; 1c+2M LHA (2W up on [7-8]) to (2,1,3)

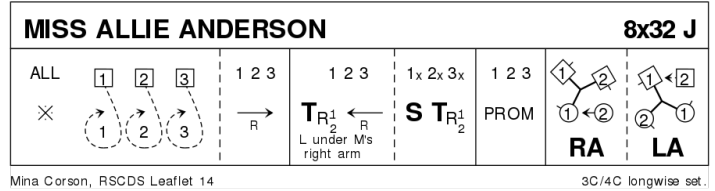

## 2 THE COUNTESS OF DUNMORE'S REEL R32 · 3/4L

Deirdre MacCuish Bark: *RSCDS XLIX 12* · Crib: *SCDDB Contributed Cribs & Diagrams* · Diagram: *Keith Rose's Diagrams*

- 1-- 1c set | dance down (2c up) ; cast up round 3c | set advancing to face 1c nr
- 9-- 1c turn 1cnrs RH, pass Rsh; turn 2cnrs RH, pass Rsh to face out in 2pl (cnrs dance for {4})
- 17-- [3C Chain Progression] 1c cast ¼ clw round set while{} 2c & 3c Turn RH ¾ | 2M+3W turn 1½ LH while{} the others promenade ½ clw round set | 3c+2c turn RH ¾ while{} 1c dance clw to 2pl
- 25-- all chase ½ way clw ; set - cross RH

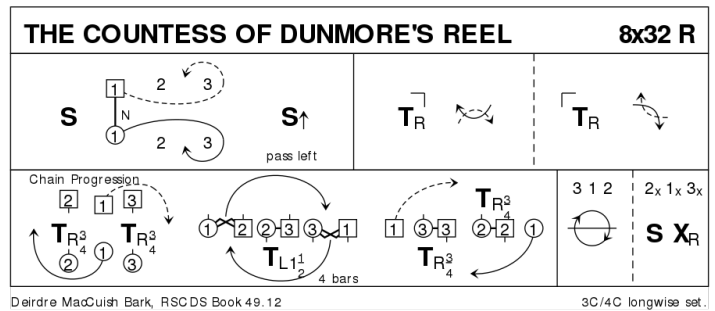

3C Chain Progression was earlier known as Chaperoned Chain Progression

## 3 THE MORAY RANT S48 · 3/3L

John Drewry: *Silver City Book of SCD* · Crib: *Eric's E-cribs* · Diagram: *Keith Rose's Diagrams*

- 1- Inveran reels{6} (1c cross down from top, cross up from bottom) | 1c cross RH to (1x,2,3)
- 9- 1c set advancing | turn BH ; dance down between 2c, cast behind 3c, finish BtoB between 3c facing opp. side
- 17- 1M+3W & 1W+3M set & turn EH ¾ (1c start out between 2c and 3c) ; 1c dance up , cast up behind 2c, finish BtoB between 2c facing opp. side
- 25- 1M+2W & 1W+2M set & turn EH ¾ (1c start out between 2c and 3c) ; 1c ½Fig8 round 2c to (1,2,3)
- 33- 1c+2c Circle4 L ; 1c facing 2c NHJ set and 1c face up | 1c cast off **while{2}** 2c lead up (2,1,3)
- 41- 1c+3c repeat [33-40] to (2,3,1)

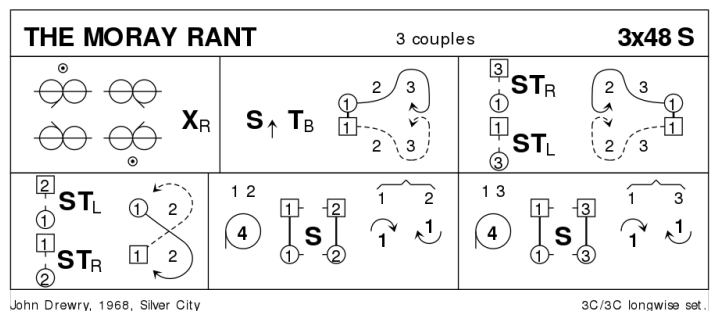

## 4 NEIL M GRANT J32 · 3/4L

Christine Grant: RSCDS XLIX 1 · Crib: Eric's E-cribs · Diagram: Keith Rose's Diagrams

- 1-- 1c cross RH | cast off (2c up) ; ½ Fig8 R (round 3cnr) to join with P LH and 1cnrs RH
- 9-- The Spoke: BiL{1}, advance LHJ cclw to next cnr {1} | repeat 3 times, finish facing 1cnr
- 17-- 1c+1cnrs ½ diag Reel4, pass Rsh ; 1c+2cnrs ½ Diag Reel4 (3x,1x,2x)
- 25-- all chase clw half round ; teapots R (2,1,3)

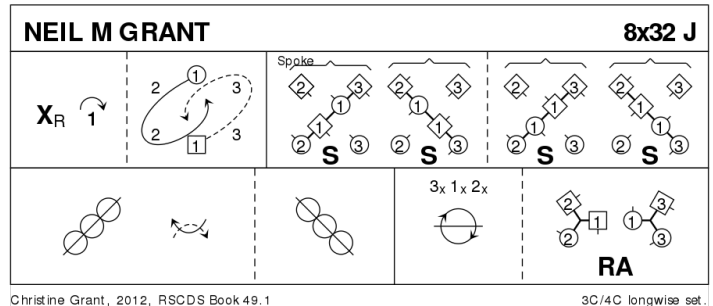

## 5 WHIGMALEERIES R32 · 3/4L

Derek Ivory: Imperial Book of Scottish Country Dances - Volumes 1-3 · Crib: Eric's E-cribs · Diagram: Keith Rose's Diagrams

- 1-- 1c set adv | Turn single R ; slip down BHJ and cast up (2c up) (2,1,3)
- 9-- Teapots R (2c+1W & 1M+3c RHA) ; 1c pass Lsh, cast L round 2cnr and meet in promhold facing 3W (2,1,3)
- 17-- 1c ½ Reel3 across with 3c, Rsh to 3W ; 1c split into ½ Reels3 on own side, starting out and up
- 25-- 1c in promhold (M on R) ½ Reel3 across with 3c, Rsh to 3W ; 1c split into ½ Reels3 on own side, starting out and down (2,1,3)

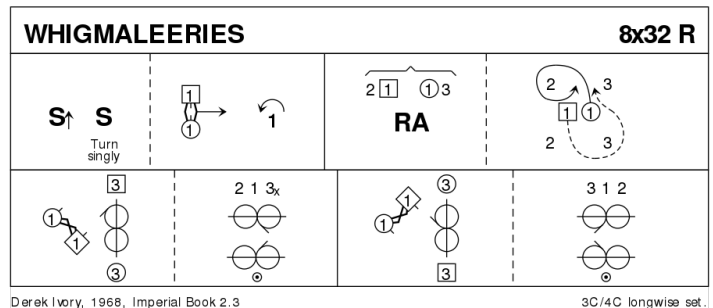

## 6 BARBARA'S STRATHSPEY S32 · 3/4L

Sue McKinnell: RSCDS XLVI 4 · Crib: Eric's E-cribs · Diagram: Keith Rose's Diagrams

- 1-- 1c set | cast (2c up) ; ½ Fig8 L (2,1x,3)
- 9-- All set | 1c cross Rsh ; 1c+3cnr turn RH 1½ (to 1,2,3 on M side, 2,3,1 on W side)
- 17-- 3C Bourrel: 2W+3M chase cclw half round to midline while{4} 1M+3W & 2M+1W set adv | turn BH ¾ and pivot R, all facing P on midline (3,1,2) ; All set | All C turn BH ¾ to sidelines
- 25-- All chase clw ½ round ; all turn P RH ½ and twirl R to (2,1,3)

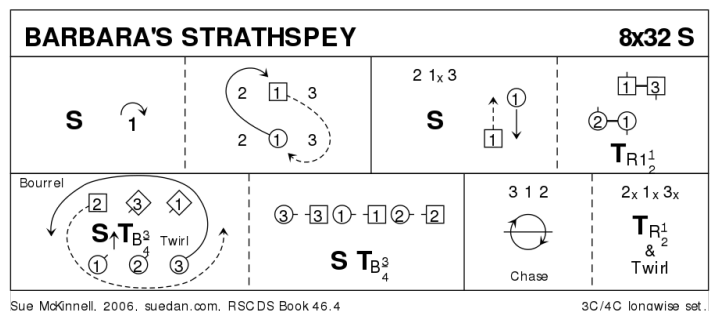

## 7 THE IMMIGRANT LASS J32 · 4/4L

Morton Jay: RSCDS XXXIX 5 · Crib: Eric's E-cribs · Diagram: Keith Rose's Diagrams

- 1- 1c+2c turn RH 1½ ; 1c+2c RHA **while** {} 3c+4c turn RH 1½  
 9- 1c+2c ½ R&L **while** {} 3c+4c RHA ;  
 1c+3c ½ R&L (2,3,1x,4x)  
 17- 3c+1c L-Chain  
 25- 1c+4c lead up {3}, change sides (M loop above **while** {} W under M's arm) ; lead down | 4c casts up **while** {} 1c dances straight into 4pl (2,3,4,1)

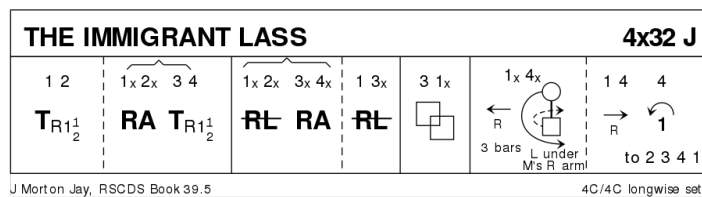

## 8 THE POWDER MONKEY M128 · 4S

Sue Tyler: Exeter Branch 40 · Crib: MiniCribs

- 1-8 All dance interlocking reels of 4 (all pass partner RSh, next person LSh & following person RSh) & end with hands joined with corners  
 9-16 All Set+Link with corners, All advance 1 step with corner & retire 1 step with next person (to end in a square) & set  
 17-24 1s+3s (sides) dance 1/2 R&L, 2s+4s (top & bottom) dance 1/2 R&L  
 25-32 All Set+Link with corners, All advance 1 step with corner & retire 1 step with partner (to end in a square) & set  
 33-40 Ladies dance in front of partner & behind next Man, then dance 3/4 RH across & turn partner LH into RH across joined NH with partner  
 41-44 All dance RH across 1/4 way then change places with partner & dance another 1/4 RH across (Men in centre)  
 45-48 All dance another 1/4 RH across then Men dance out followed by partners to end 1/2 way round set  
 49-56 All dance double Men's Chain & end Ladies facing out  
 57-64 All dance 1/2 Schiehallion reel & end in original places  
 Repeat in reel time but in bars 13-16 & 29-32 all advance 2 steps & retire 2 steps & omit setting.

## 9 SUPPER

## 10 ROARING JELLY J32 · 3/4L

Hugh Foss: Glendarroch Scottish Dance Sheets · Crib: Eric's E-cribs · Diagram: Keith Rose's Diagrams

- 1- 1c cross RH | cast off (2c up) ; cross RH, 1c casts R round 3c to finish in line across between 2c and 3c  
 9- Circle6 and back  
 17- 1c change places up/dn RH | Fig8 round 4c and 1c, (start Rsh), finish on sideline facing 2c  
 25- 1c Reels3{6} on opposite sides (Rsh to 2c) | cross RH

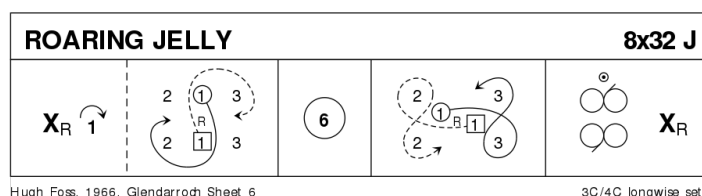

## 11 BROADFORD BAY R32 · 3/4L

Anne Grant: *The Leaflet Dances with Music* · Crib: *Eric's E-cribs* · Diagram: *Keith Rose's Diagrams*

- 1- 1c (leading)+2c (dance up to begin), dance between 3c, cast up and dance to top, and 1c cast off (to 2,1,3)
- 9- 2c+1c+3c G-Chain (2c cross to start), finish 2M & 1W facing out (2,1,3)
- 17- 2W+1M turn RH 1½ **while{4}** 2M+1W chase ½ round cclw ; 2W+1M chase ½ round clw to 1W/2M places **while{4}** 2M+1W turn LH 1¼ to face P on 2diagonal
- 25- 2c+1c diagonal Reel4 (to 2,1,3)

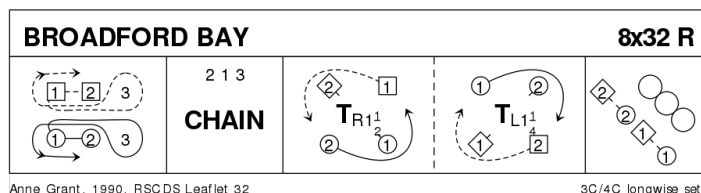

## 12 THE CASHMERE SHAWL S32 · 3/4L

Iain Boyd: *The Strathtay Album* · Crib: *Eric's E-cribs* · Diagram: *Keith Rose's Diagrams*

- 1- 1c turn RH | cast off 2 (2c+3c up) ; cross LH | cast up to 2pl (3c down) (2,1x,3)
- 9- 1c turn P RH, 1cnr LH ; 2cnr RH, P LH to face 1cnrs
- 17- ½Reel4 on 1diag and pass Rsh ; ½Reel4 on 2diag ; ending (3x,1x,2x)
- 25- (»Chain«:) Middle couple change places RH with person diag. to R | new middles repeat LH and L ; repeat R, all C cross LH (2,1,3)

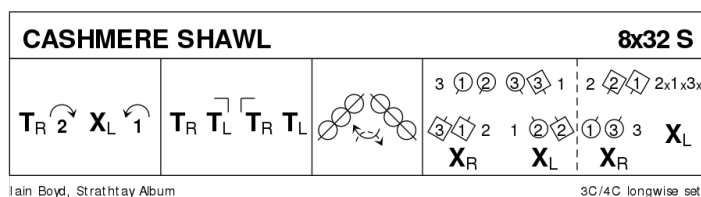

## 13 GAELFORCE WIND J32 · 3/4L

Derek Haynes: *A Third Book of Graded Scottish Country Dances* · Crib: *Eric's E-cribs* · Diagram: *Keith Rose's Diagrams*

- 1- 1c set and cross RH, 1c+2c S&Link, 2W+1W finish facing out. (2,1x,3)
- 9- 2c+1c M-Chain.
- 17- 1c ½ Fig8 L (Rsh to 4cnr) ; All turn RH (2,1,3)
- 25- All Circle6 and back (2,1,3)

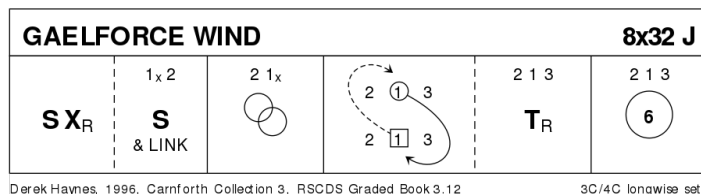

## 14 MIDNIGHT OIL J48 · 5/5L

John Drewry: Bankhead Book Part 3 · Crib: Eric's E-cribs · Diagram: Keith Rose's Diagrams

- 1-- 1c+3c lead far down (2c+4c up) | turn  $\frac{3}{4}$  RH and face P, RHJ ; set , W turning under M's arm | 1c+3c dance up (W leading)
- 9-- 1c+2W & 3c+4W RHA ; 1c+4M & 3c+5M LHA, 1c+3c finish facing 1cnrs
- 17-- 1c+3c with 1cnrs pass and turn, pass P Rsh ; repeat with 2cnrs, at end pass P Rsh onto midline, W above and facing M
- 25-- Reel4 on midline, at end pass Rsh in the middle to finish 1c facing out in 2pl on W side / likewise 3c in 4pl on M side
- 33-- 1c dance out between 2W & 4W, split, cast round them, meet in middle, repeat through M side **while{8}** 3c do the same, starting between 4M & 5M. (1M & 3W pass Lsh between 4c). All finish where they started the reel, but 1M faces 3W
- 41-- 1W+3M set twice facing up and down **while{4}** 1M+3W turn RH to face P ; 1c+3c turn P LH  $\frac{3}{4}$  | cast off on own side (4c+5c up) (2,4,1,5,3)

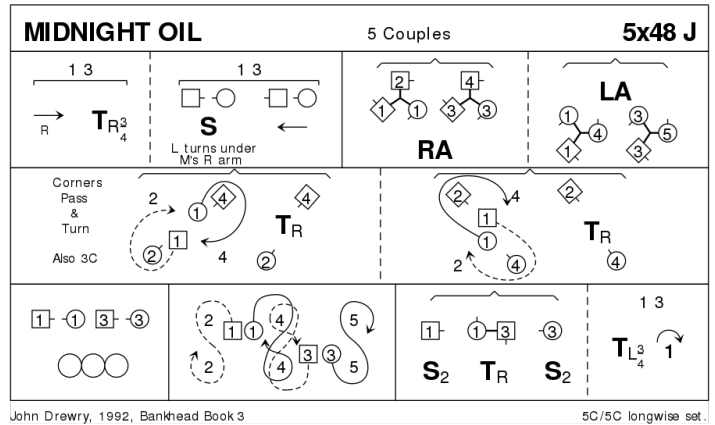

## 15 CULLA BAY S32 · 4S

Ann Dix: RSCDS XLI 2 · Crib: Eric's E-cribs · Diagram: Keith Rose's Diagrams

- 1-- 1c+3c turn RH  $\frac{1}{2}$  with person opposite, face that person | twirl R and into opposite place ; 2c+4c repeat this and face in **while{4}** 1c+3c (W leading) chase  $\frac{1}{4}$  clw | curve into centre and swivel R to face out (1c facing 4pl and 3c facing 2pl)
- 9-- Parallel Reels4 across
- 17-- 2c+1c & 3c+4c circle4 L ; face other couple and set |  $\frac{1}{2}$  RHA, flowing into
- 25-- 2c+4c LHA in the middle ; dance out passing same sex standing dancer on the side Rsh, and chase R (M leading) to 1pl/3pl (to 2,3,4,1).

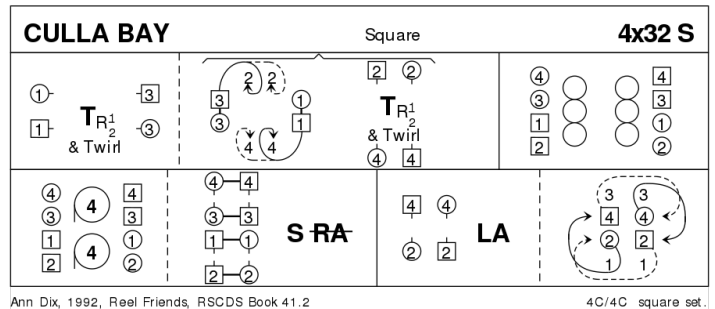

## 16 THE ZOOLOGIST J32 · 3/4L

Duncan Brown: RSCDS XLVI 12 · Crib: Eric's E-cribs · Diagram: Keith Rose's Diagrams

- 1- 1c cross down RH (2c up) and cast R to between end cpl facing 4cnr ; ½ Lsh Reels3 across, 1c face 1cnr (pos)
- 9- ½ Reel4 on 1diag, 1c pass Rsh and face 2cnr pos. ; ½ Reel4 on 2diag, 1c finish BtoB in middle facing opposite side (3, 1x\_mid, 2)
- 17- DTr, 1c finish Rsh to Rsh facing opposite side
- 25- 3c+1M & 1W+2c LHA finish as started ; 1M leading 3c & 1W leading 2c dance to 1cnr {1}, 4cnr {2}, 2pl own side {1}, to finish (2,1,3). This is like the »Snake Pass«, but with sharp angles, forming the letter »Z« for Zoologist (from a note by the deviser).

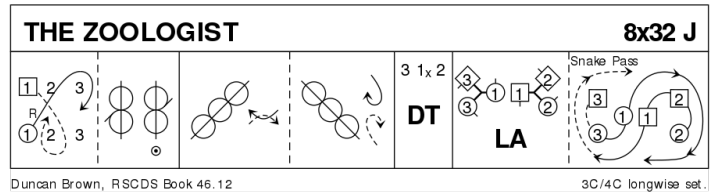

## 17 THE HIGHLAND RAMBLER R40 · 3/4L

Roy Goldring: Silver Jubilee 25 - Leeds Branch · Crib: Eric's E-cribs · Diagram: Keith Rose's Diagrams

- 1- 1c long cast to 2pl (2c up on [3-4] ; 1c+3c RHA (2,1,3)
- 9- 2c+1c LHA, 1W faces out ; 1W followed by 1M cast up round 2W and down the middle of set, 1W between 3c and 1M between 2c, all facing down
- 17- In lines of 3 down the middle (all swivel R) and up
- 25- 1M followed by 1W dance up, cast round 2W and into 2pl ; 1c turn RH
- 33- Circle6 and back

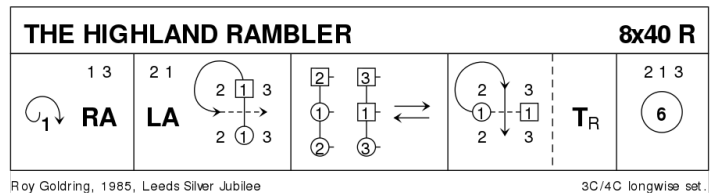

## 18 EXTRAS

## 19 JEAN MARTIN OF ABERDEEN S32 · 3/3L

Muriel A Johnstone: Magazine Dances 2005-2009 · Crib: Eric's E-cribs · Diagram: Keith Rose's Diagrams

- 1- 1c Turn RH, cast (2c up) ; All circle6 L ¾ into lines across (W facing down, M up)
- 9- All set | change places RH with P ; All circle6 L left ¾ and end in middle facing up (3,1,2) for
- 17- Allemande (2,1,3)
- 25- 1c+3c Bourrel : 1M+3W set adv. | Turn BH ¾ & twirl to end BtoB in middle, 3W facing up & 1M down while{4} 1W+3M chase cclw to face P set to P | Turn BH ¾ to (2,3,1)

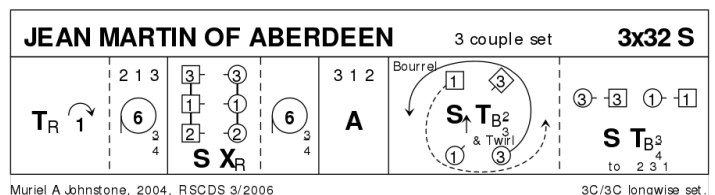

## 20 BLOOMS OF BON ACCORD

R32 · 4/4L

John Drewry: Deeside Book Part 2 · Crib: Eric's E-cribs · Diagram: Keith Rose's Diagrams

3c+4c cross on 2nd chord(1,2,3x,4x). This dance has top/bottom symmetry

- 1- All C set | 1c+2c & 3c+4c RHA | 1c & 4c cast in to 2pl/3pl **while{2}** 2c+3c lead out to end places
- 9- 1c+4c cross RH, cast to ends, meet in promhold and dance in between end couples, curve round the other couple Rsh to finish 1c / 4c on M/W side facing out and right
- 17- 1c & 4c (in promhold) Rsh Reels3 with the »corners« on M/W sides, at end meet in the centre
- 25- 4c+1c RHA, at end M swivels right so couples face ends of set (1c down, 4c up, W on P's left, RHJ) ; 4c&1c cross down between end couples and cast in to 3pl/2pl (to 2,4,1x,3x)

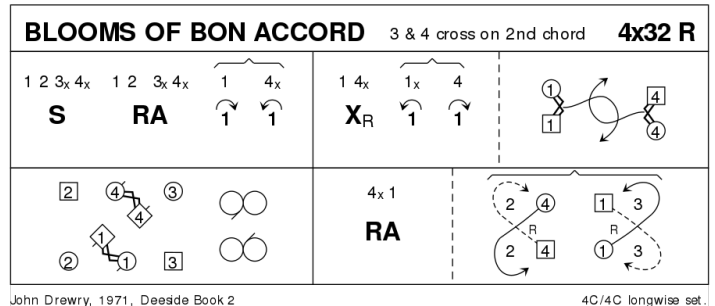

## 21 THE SAILOR

R32 · 3/4L

RSCDS XXIV 4 · Crib: Eric's E-cribs · Diagram: Keith Rose's Diagrams

- 1- 1c cross down RH (2c up) to 2plx and BiL with cnrs ; 1c cast R into lines across | all set
- 9- All Reels3 across, Rsh to 1cnr, finishing (2,1x,3)
- 17- 1c lead down | lead to the top ; cross and cast to (2,1,3)
- 25- 2c+1c R&L.

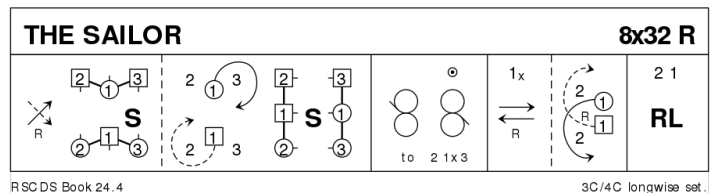

Note: [3-4] is NOT in DT<sub>r</sub> position.

## 22 HOOPER'S JIG

J32 · 3/4L

Miss Milligan's Miscellany of Scottish Country Dances · Crib: Eric's E-cribs · Diagram: Keith Rose's Diagrams

- 1- All clap, 1c cross Rsh and cast off one (2c up) ; 1c+3c RHA
- 9- All clap, 1c cross back Rsh, cast up to own place (2c down) ; 1c+2c LHA
- 17- 1M+3W change places RH | 1W+3M change RH, **while{2}** 1M+3W dance a Rsh loop ; 1M+3W cross back RH **while{2}** 1W+3M loop | 1W+3M cross back LH, 1W to 2pl **while{2}** 1M casts to 2pl (2c up)
- 25- 2c+1c R&L

