

RSCDS Leeds Branch 16 May 2026

1 JOIE DE VIVRE J32 · 3/4L

Irene van Maarseveen: RSCDS XXXIX 2 · Crib: E-cribs · Diagram: Keith Rose's Diagrams

- 1- 1c set | cast (2c up) ; dance between 3c and cast up to (2,1,3)
- 9- All turn P RH to sidelines ; all chase clw half round (to 3x,1x,2x)
- 17- All dance BtoB ; all set | all ½ RH turn into
- 25- 3c+1c+2c Allemande (2,1,3)

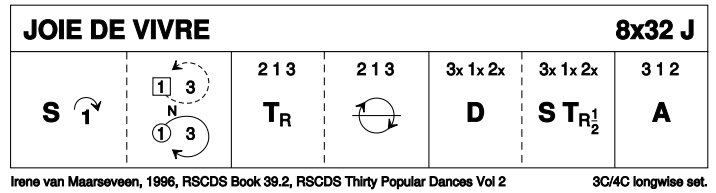

2 THE CRAVEN REEL R32 · 3/4L

Derek Haynes: Carnforth Collection of SC Dances 5 · Crib: E-cribs · Diagram: Keith Rose's Diagrams

- 1- 1W+1M following cast off 2 (2c+3c up) and cross ; 3c+1c RHA (1W face out)
- 9- 1W+1M following cast up to 1pl (2c+3c down) ; 1c+2c RHA (1,2,3)
- 17- Parallel Reels3 on own side, 1c Rsh to 2c (1,2,3)
- 25- 1W with 1M following cast off 1, cross up between 2c, cast Lsh round 2M (2c up) to (2,1,3)

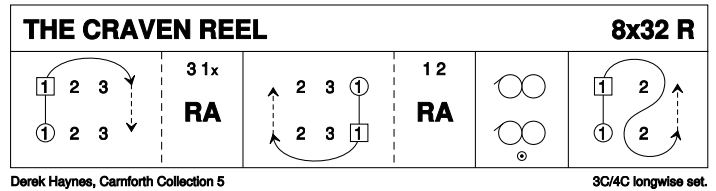

3 SLYTHERIN HOUSE S32 · 3/4L

Chris Ronald: RSCDS LII 3 · Crib: E-cribs · Diagram: Keith Rose's Diagrams

- 1- 1c+2c S&Link ; Circle4 L (2,1,3)
- 9- 1c cast clw round 3cnr, pass Lsh up/down, cast Lsh round 1cnr and turn P LH to midline, M below W
- 17- 2c+1W & 1M+3c RHA ; (Snake) 1W+2W+2M & 1M+3M+3W unwind, pass the other dancers Lsh and loop L to (3,1,2)
- 25- 3c+1M & 1W+2C LHA ; (Snake) 1W+2W+2M & 1M+3M+3W unwind, pass the other dancers Rsh and loop R to (2,1,3)

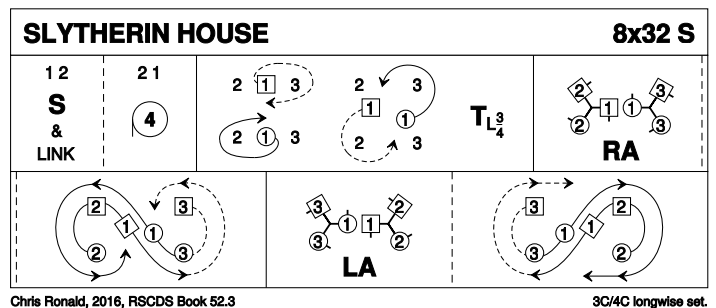

4 THE SCALLYWAG J40 · 3/4L

Jennifer Kelly: RSCDS LII 5 · Crib: E-cribs · Diagram: Keith Rose's Diagrams

- 1- 1c long cast (2c up) ; turn LH to face 1cnr
 9- 1c set to 1cnr | Turn 1cnr RH $\frac{3}{4}$ into lines across and face 4cnr ; $\frac{1}{2}$ Lsh Reel3 across into facing lines across
 17- Lines A&R ; 1c dance Rsh round P to face 3cnr (pos)
 25- repeat [9-16] with these corners, finishing 1M between 2c facing 1W between 3c
 33- 1c set adv and join RH | set RHJ, 1W turning under the arms and 1c face up RHJ still on opp. side ; 1c cross up and cast to 2pl (2,1,3)

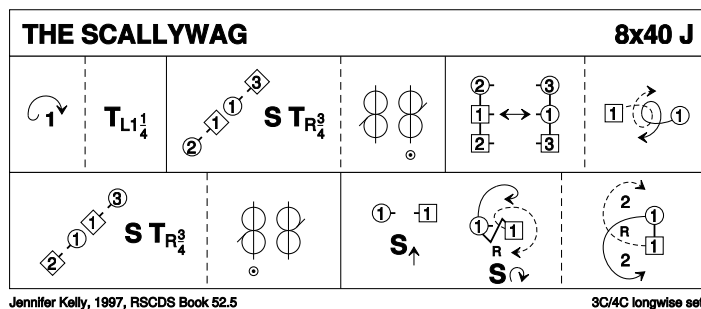

5 SLEEPY MAGGIE R32 · 3/4L

Alexander Bowman: RSCDS XI 5 · Crib: E-cribs · Diagram: Keith Rose's Diagrams

- 1- 1c+2c circle4 to the left ; 1c set | cast off (2c up)
 9- 1c+3c RHA ; LHA, 1c finish facing 1cnrs
 17- 1c set to and turn corners, finish facing 1cnrs
 25- Reels3{6} with cnrs (Lsh to 1cnr), 1c cross RH (2,1,3).

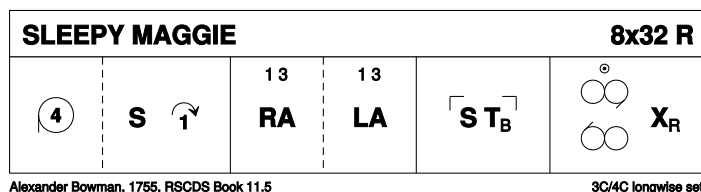

6 SEAGREEN S32 · 3/3L

John Drewry: Summer Collection 1989 · Crib: E-cribs · Diagram: Keith Rose's Diagrams

- 1- 1c+2c+3c set | {1M+3W petronella-turn to finish BtoB between 2c with 1M facing up and 3W facing down ; dance through P's place | cast R to exchanged places} **while**{6} {1W+3M cast clw to other end ; petronella to finish BtoB with 3M facing up and 1W facing down | both dance out to exchanged places (3x,2,1x)
 9- All set, circle6 L. On [14], all drop hands, dance into the centre pulling Rsh back to face out, and dance clw to starting places (3x,2,1x)
 17- 3c+2c+1c repeat figure [1-8] to (1,2,3)
 25- 2c followed by 1c dance down NHJ between 3c and cast up to 1pl / 2pl ; 1c with 3c following dance up NHJ between 2c and cast off to 3pl / 2pl (to 2,3,1)

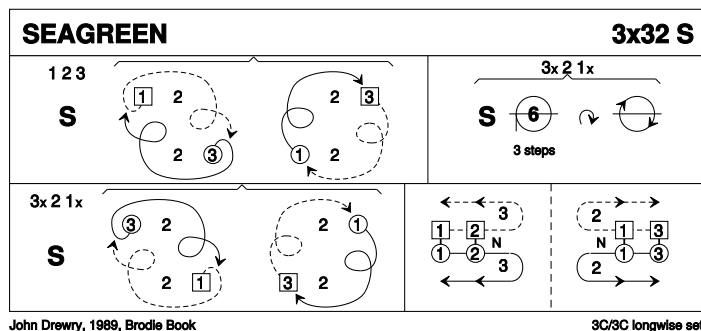

7 BILL CLEMENT MBE J32 · 3/4L

John Wilkinson: RSCDS XLVII 1 · Crib: E-cribs · Diagram: Keith Rose's Diagrams

- 1- 1c set | dance between 3c (2c up) and cast up to finish side by side LHJ facing 1cnr
- 9- Set to 1cnr and turn inwards and join RH | set to 3cnr ; turn 3cnr LH to face 2cnr RHJ
- 17- Set to 2cnr and turn inwards and join LH | set to 4cnr ; turn 4cnr RH to (2,1,3)
- 25- Circle6 and back

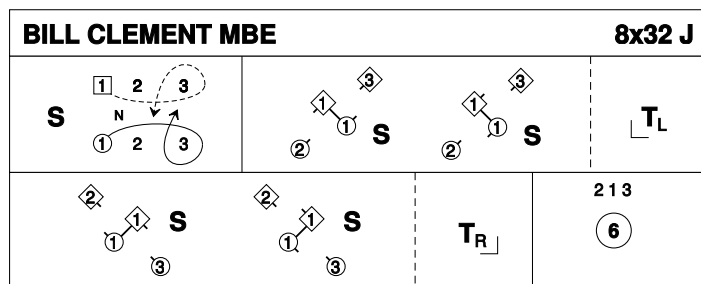

John Wilkinson, 2008, RSCDS Book 47.1

3C/4C longwise set.

8 TOGETHERNESS R32 · 3/4L

John Drewry: The Brodie Book · Crib: E-cribs · Diagram: Keith Rose's Diagrams

16-bar pattern: ½ RH turn | Promenade down 2 places ; cross LH | cast up one ; Set turning to | cast up 1 place ; turn RH ½ | Promenade down 1 place to face 2M position.

- 1-16 1c dance pattern **while**{16} 2c set turning and cast up 1 place ; and follow pattern for 12 bars **while**{16} 3c set turning and cast up ; repeat ; follow pattern for 6 bars | set to P
- 17- 2M+1c+3W diagonal Rsh. Reels3
- 25- 2W+1c+3M diagonal Lsh. Reels3 (but 1c ½Reel, dance up through 1pl, cast off to 2pl)

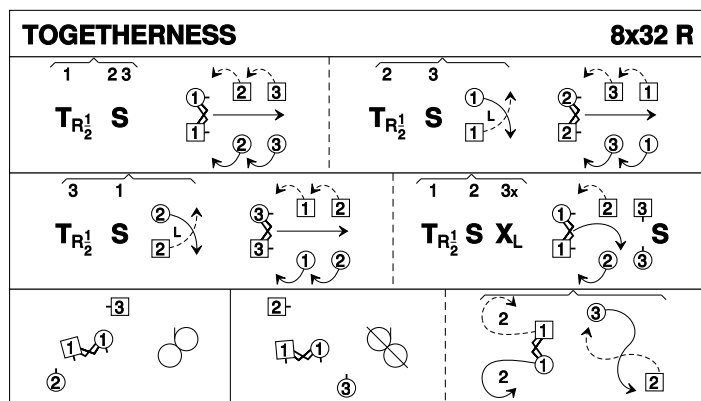

John Drewry, 1988, Brodie Book

3C/4C longwise set.

Interval

9 THE LAST OF THE LAIRDS J32 · 3/4L

Hugh A Thurston: RSCDS XXII 5 · Crib: E-cribs · Diagram: Keith Rose's Diagrams

- 1- 1c+2c+3c Reels3 on opposite side, all crossing from the top, 2c starts out and up (1x,2x,3x)
- 9- 1c+2c+3c Reels3 on own sides, all crossing back from the top (1,2,3)
- 17- 1c set, cross RH, cast off (2c up) ; cross down LH between 3c and cast up (2,1,3)
- 25- 1c dance to top and cast off ; all turn P RH (2,1,3)

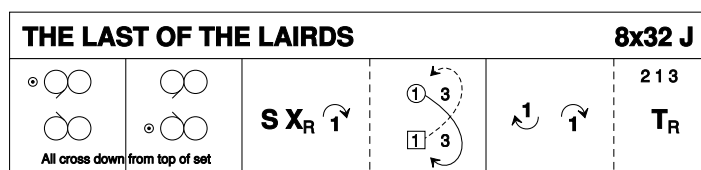

Hugh Thurston, RSCDS Book 22.5

3C/4C longwise set.

10 STANFORD SWING J40 · 3/4L

Bob McMurtry: *The Devil's Quandary Book 2* · Crib: *E-cribs* · Diagram: *Keith Rose's Diagrams*

- 1- 1c set | cross RH ; cast off (2c up) | Turn LH $\frac{3}{4}$ to face 1cnr
- 9- 1c+1cnrs set | La Baratte [turn RH $\frac{1}{2}$ to full arms' length | change back sideways, W passing in front with her back to M, changing hands overhead to LH | turn LH $\frac{1}{2}$ to exchanged places], 1c face out and 1cnrs face in
- 17- 1cnrs turn RH, and dance through 2pl to own place **while**{4} 1c dance Lsh round 2cnr and in through the ends ; 1c turn LH $1\frac{3}{4}$ to face 2cnr
- 25- 1c+2cnrs set | La Baratte, 1c face out and 2cnrs face in
- 33- 2cnrs turn RH, to own place facing 1c **while**{4} 1c dance Lsh round 3cnr into 2pl facing 4cnr ; 1c+4cnr dance BtoB (2,1,3)

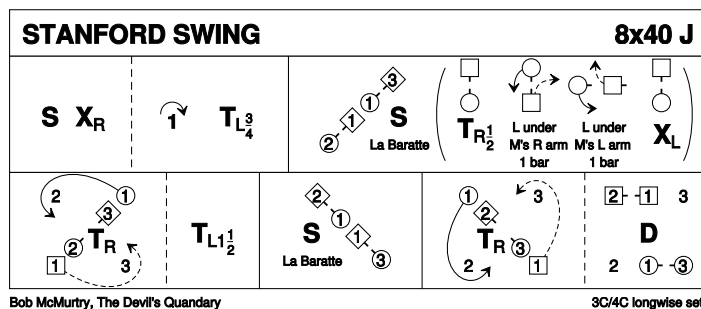

11 THANK YOU PATRICIA S32 · 3/4L

Deb Lees: *RSCDS LIV 15* · Crib: *E-cribs* · Diagram: *Keith Rose's Diagrams*

- 1- 1c set | Petronella Turn (2c up) ; 1c & 2c set, 1c advancing into line4 across, 1c facing opp sides | all turn opp person BH, 1c finishing in tandem (1W leading) facing 2M
- 9- $\frac{1}{2}$ Reel3 in tandem (with lead change) on 1diag, 1c RSh to 2M. 1c (1M leading) face 3M ; $\frac{1}{2}$ Reel3 in tandem (with lead change) on 2diag, 1c RSh to 3M. 1c finish in 2pl centre facing up NHJ, 1W pulling RSh back to finish on P's Right
- 17- 1c dance up | cast off to 2pl (to 3x,1,2x) ; 1c turn P RH **while**{4} 2c & 3c set | turn P RH $\frac{1}{2}$, all 3C into allemande hold
- 25- 3C Allemande (2,1,3)

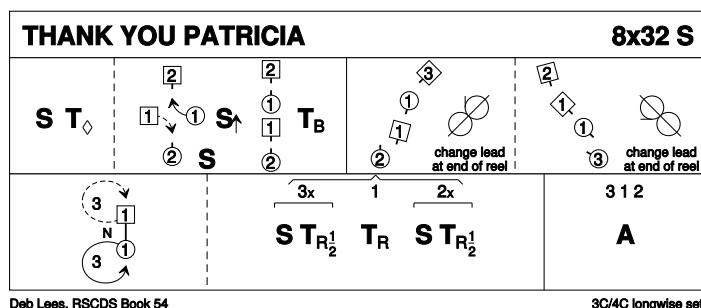

12 GAELFORCE WIND J32 · 3/4L

Derek Haynes: *A Third Book of Graded Scottish Country Dances* · Crib: *E-cribs* · Diagram: *Keith Rose's Diagrams*

- 1- 1c set and cross RH, 1c+2c S&Link, 2W+1W finish facing out. (2,1x,3)
- 9- 2c+1c M-Chain.
- 17- 1c $\frac{1}{2}$ Fig8 L (Rsh to 4cnr) ; All turn RH (2,1,3)
- 25- All Circle6 and back (2,1,3)

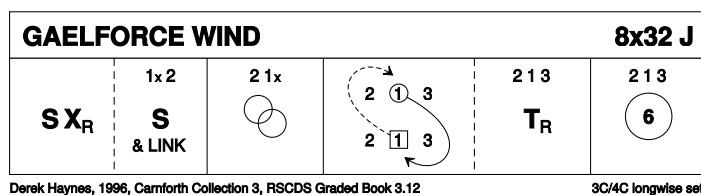

13 THE INIMITABLE DEREK R32 · 3/4L

Roy Goldring: Magazine Dances 2005-2009 · Crib: E-cribs · Diagram: Keith Rose's Diagrams

- 1- 1W+2W & 1M+2M turn 1¼ EH, 1c starting inwards, into line across with 1c BtB in the middle | 1c+2c set ; turn with the other hand ¾ (1c starts up) to (2,1,3), 2c facing out
- 9- Opposing Reels3 on the sides, 1c start to the R (1M Rsh to 3M, 1W Rsh to 2W), on [13-14] 1c cross to "2cnr position, on [15-16] 1c turn 2cnr persons (2W and 3M) RH into 2diagonal line
- 17- 1c+2cnrs BiL | 1c turn LH to join 1cnr with RH ; BiL | 1c turn LH to finish side by side in the centre, 1W facing up, 1M down
- 25- 1W+2W+3W & 1M+2M+3M RHA ; 1M+1W dance out the end and cast R into (2,1,3)

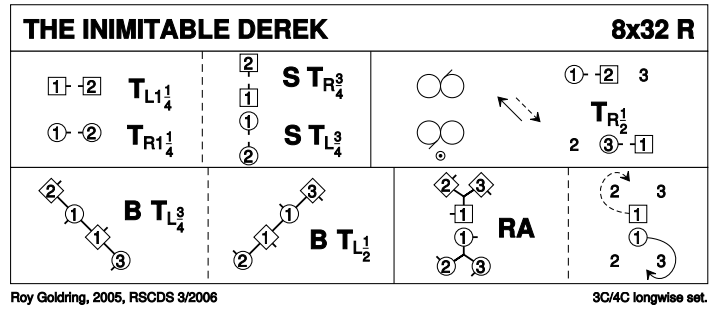

14 THE MINISTER ON THE LOCH S32 · 3/3L

Roy Goldring: Magazine Dances 2005-2009 · Crib: E-cribs · Diagram: Keith Rose's Diagrams

- 1- 1c+2c Pousette
- 9- 1c dance down 2 places, turn BH ; dance up 2 places, turn BH, open upwards and face out
- 17- 1c+3c DblFig8 round 2c, 1c casting, 3c crossing up to begin, 1c finish facing out for
- 25- 1W+2W & 1M+2M turn EH 1½ ; 1c+3c repeat (2,3,1)

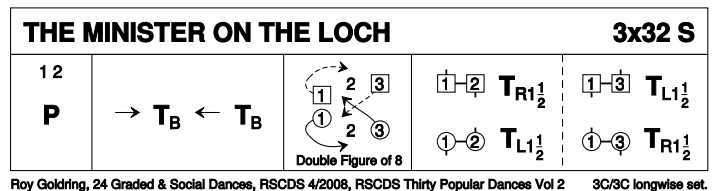

15 THE WILD GEESE J32 · 3/4L

RSCDS XXIV 3 · Crib: E-cribs · Diagram: Keith Rose's Diagrams

- 1- 1c+3c set advancing to midline with P on R | BiL ; 1c turn ¾ RH and cast off to 3pl while(4) 3c turn ¾ RH and lead to 1pl (3,2,1)
- 9- Repeat [1-8] from new positions (1,2,3)
- 17- 1c lead down the middle (2c up on [19-20]) ; and up to (2,1,3)
- 25- 2c+1c R&L

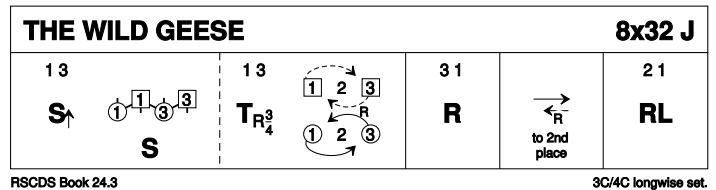

16 TRIP TO TIMBER RIDGE R32 · 3/4L

Linda Henderson: RSCDS LII 12 · Crib: E-cribs · Diagram: Keith Rose's Diagrams

- 1- 1c turn RH | cast (2c up) ; 1W+2c & 1M+3c RHA, 1c facing 1cnrs at end
- 9- Corners Pass and Turn, on [16] 1c pull Rsh back to finish BtoB in centre facing opposite side
- 17- DT_R, on [23-24] 1c Petronella turn to 2pl (2,1,3)
- 25- Circle6 and back

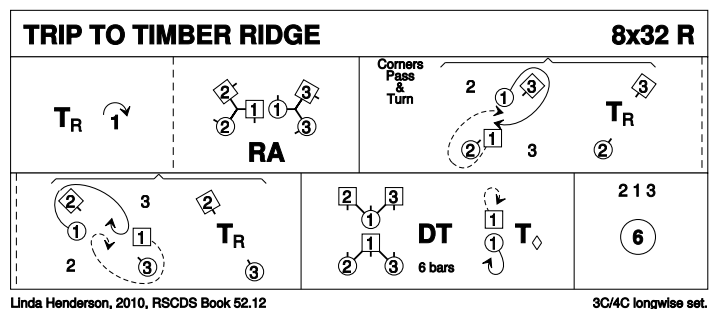

Extras

17 [?] LANGHOLM FAIR S32 · 3/3L

Jean Attwood: Alexander Dances Book 3 · Crib: E-cribs · Diagram: Keith Rose's Diagrams

- 1- 1M leading +2M+3M dance across the top and down to behind the Women ; all M cross to own side (1M below 3W, 2M below 2W. 3M below 1W) | All set
- 9- Teapots R ; and L (2c RHA with pair to the R ; LHA to the L)
- 17- 1W leading +2W+3W dance across the top and down behind the M to join own P (who swivels $\frac{3}{4}$ L on [20] into promhold facing down ; half 3C Promenade to finish 1c in the middle facing up, 2c & 3c on sides (1,2,3)
- 25- 1c cast off as 2c dance to top | 1c turn BH ; cast off to 3pl (3c up) | 1c turn BH. (2,3,1)

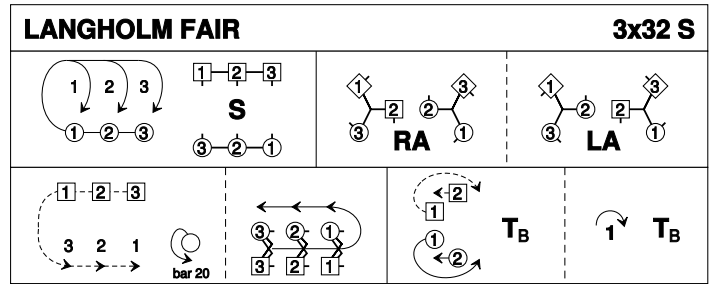

Jean Attwood, Alexander Dances Book 3

3C/3C longwise set.

18 [?] THE FALLS OF ROGIE R32 · 3/4L

Jean Attwood: Alexander Dances Book 1 · Crib: E-cribs · Diagram: Keith Rose's Diagrams

- 1- 1c cross RH | cast (2c up) ; cross RH | cast R (M up, W down)
- 9- $\frac{1}{2}$ Reels3 across (Lsh to 2cnr) ; set in lines across | all cross up/down RH
- 17- Corners chase once clw **while(8)** 1c chase half way clw and turn RH $1\frac{1}{4}$ to face 1cnr positions
- 25- $\frac{1}{2}$ diag. Reel4 with 1cnrs, 1c pass Rsh ; $\frac{1}{2}$ diag. Reel4 with 2cnrs, 1c passing Rsh to 2pl.

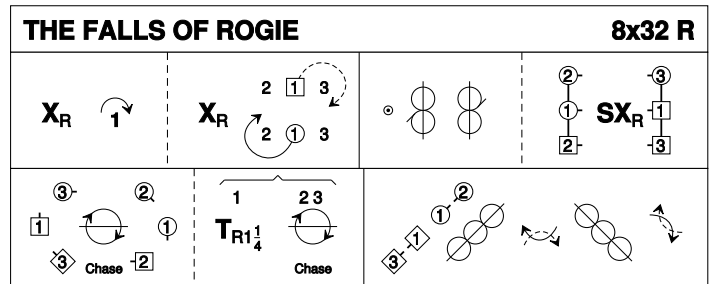

Jean Attwood, Alexander Dances Book 1

3C/4C longwise set.