

RSCDS Leeds Branch Dance 19 October 2024

1 ECCLEFECHAN FELINE J32 · 3/4L

Bob McMurtry: *Le Petit Chat Celtique* · Crib: *E-cribs* · Diagram: *Keith Rose's Diagrams*

- 1- 1c Fig8 on own side (start in and down ; take NH where possible).
- 9- 1c+2c+3c Mirror Reels3 on own sides (2c start out & up)
- 17- 1c dance down middle {3}, up {3}, and cast off (2c up)
- 25- Teapots R ; and L (1M+3c & 1W+2c RHA, 1c pass Rsh ; 1M+2c & 1W+3c LHA) (2,1,3)

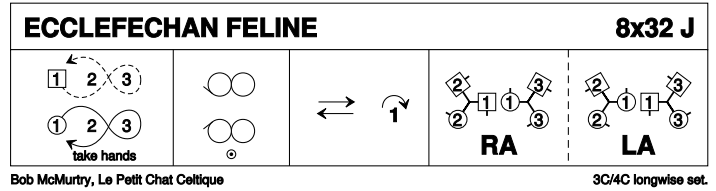

2 ANDREW'S DANCE R32 · 3/4L

Andrew 'Andy' Mills: *The Harbour City* · Crib: *E-cribs* · Diagram: *Keith Rose's Diagrams*

- 1- 1M followed by 1W cast off one, cross below 2M to 2plx ; 1M dances Rsh round 3W **while{4}** 1W dances Rsh round 3M (2c up) (2,1x,3)
- 9- 2c+1c+3c Reels3 on sides (1c Lsh to 2c) (2,1x,3)
- 17- 2c+1c L-Chain
- 25- 1c ½ Fig8 up round 2c ; 1c Turn RH (2,1,3)

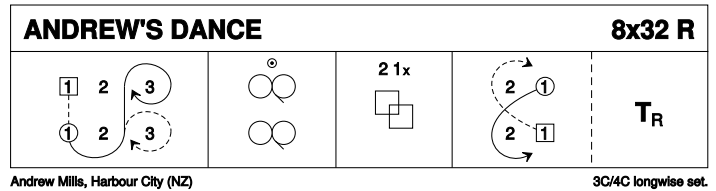

3 SNOWDROPS S32 · 3/3L

Frans Ligtmans: *Thistle Club Jubilee Book 1977-2002* · Crib: *E-cribs* · Diagram: *Keith Rose's Diagrams*

- 1- 1c turn RH | cast off (2c up) ; ½ Fig8 up (2,1x,3)
- 9- G-Chain, (2c cross to start)
- 17- 1c turns RH | cast off (3c up) ; ½ Fig8 round 3c (2,3,1)
- 25- 3c+1c R&L

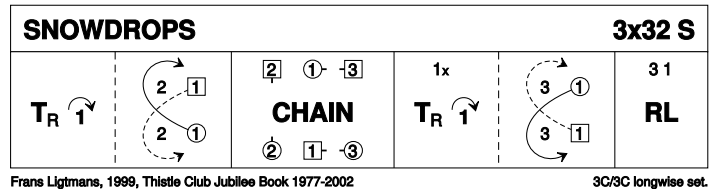

4 AIRD OF COIGACH J48 · 4/4L

John Bayley: *Imperial Book of Scottish Country Dances - Volumes 1-3 · Crib: E-cribs · Diagram: Keith Rose's Diagrams*

- 1- All four men cross above P, cast below 4W and back up own side to 4,3,2,1
- 9- All circle8 and back, end in a square set, with the dancers spaced equally around the circle.
- 17- 1M+LH person (=2M) & 1W+LH person (=2W) dance as pairs diagonally across the circle (1M pair forms arch, 1W pair passes under) through opposite places, divide and 1M & 1W cast R to pick up next person on left in the circle ; 1W+3M & 1M+3W repeat across
- 25- 1W+4W & 1M+4M repeat diagonally ; 1W+2M & 1M+2W repeat up and down
- 33- Top and bottom couples cross RH to start 4 changes of a snow ball chain, to finish Men 2,3,4,1 and Women 1,4,3,2
- 41- All women cross below opposite man, cast up round top and down own side to longwise set 2,3,4,1

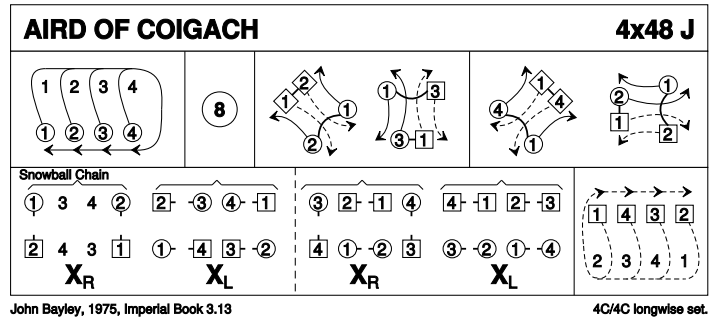

5 TRIP TO TIMBER RIDGE R32 · 3/4L

Linda Henderson: *RSCDS LII 12 · Crib: E-cribs · Diagram: Keith Rose's Diagrams*

- 1- 1c turn RH | cast (2c up) ; 1W+2c & 1M+3c RHA, 1c facing 1cnrs at end
- 9- Corners Pass and Turn, on [16] 1c pull Rsh back to finish BtoB in centre facing opposite side
- 17- DTr, on [23-24] 1c Petronella turn to 2pl (2,1,3)
- 25- Circle6 and back

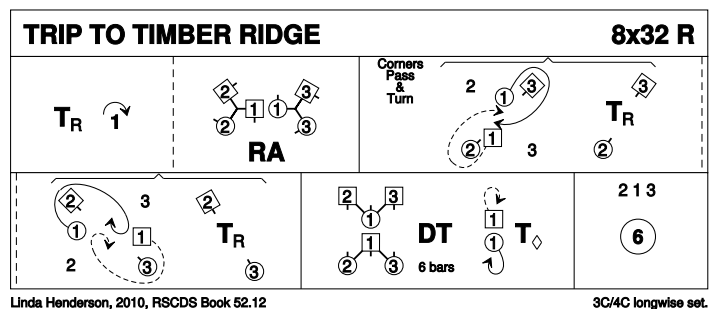

6 RED KITES OVER THE BLACK ISLE S32 · 4/4L

Ann & Ian Jamieson: *The Glen Orrin Collection · Crib: E-cribs · Diagram: Keith Rose's Diagrams*

- 1- 1c & 4c set | cast inwards (2c & 3c step out) ; 1c+4c ½ R&L (2,4x,1x,3)
- 9- All repeat pattern of [1-8] (4x,3x,2x,1x)
- 17- 4c+3c & 2c+1c RHA ; 3c+2c LHA **while(4)** 4c+1c chase clw ½. All finish as for Reel4 position (1,3x,2x,4)
- 25- All set facing on sides | change places RH (to 3,1x,4,2x) ; 3c & 2c turn P BH 1½ **while(4)** 1c & 4c turn P BH (3,1,4,2)

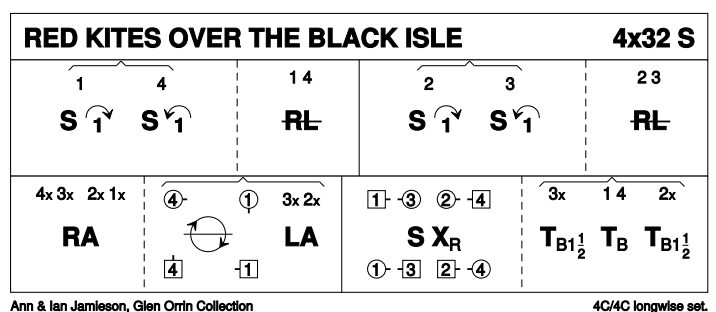

7 THE BLACK SWANS OF NARRABEEN J32 · 5/5L

Olivia Roberts: Sydney Triad · Crib: E-cribs · Diagram: Keith Rose's Diagrams

- 1- 1c+3c+5c set advancing into line of 6 NHJ, with P on the R | BiL ; 3c+5c Turn RH and lead up 2 places **while**{4} 1c cast off to 5pl (3,2,5,4,1)
- 9- Repeat from new places (to 5,2,1,4,3)
- 17- 2c+4c lead down {3}, up {3}, and cast off one (1c+3c up) (to 5,1,2,3,4)
- 25- 5c+1c & 3c+4c R&L **while**{8} 2c cross RH, Set, cross back RH, set (5,1,2,3,4)

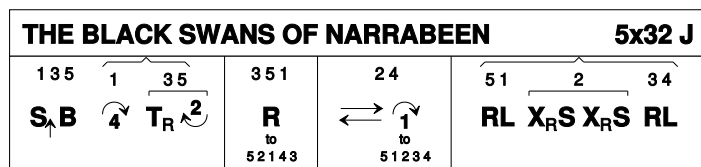

8 LADY SOPHIA LINDSAY R32 · 4/4L

Jean Attwood: Braes o' Lochaber and Three More Scottish Country Dances · Crib: E-cribs · Diagram: Keith Rose's Diagrams

On 2nd chord 3c+4c cross to (1,2,3x,4x)

- 1- 2c+3c RHA ; 2W & 3W with P following cast L round 1W & 4W "=2cnrs"
- 9- 1M+2c & 3c+4M RHA ; 1W+2c & 3c+4W LHA
- 17- 2c (on M side) & 3c (on W side) (still in tandem, W leading) opposing Reels3 on sidelines, Lsh to 4W/1W "=4cnr", to 2,1,4x,3x, middle Cs facing each other up/dn
- 25- 1c+4c set | cross RH on side ; set to P | cross RH (2,4,1x,3x)

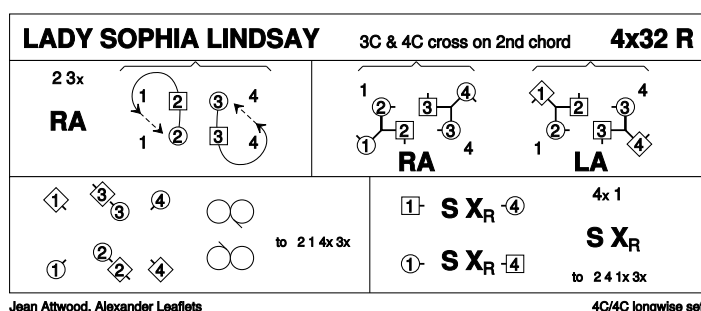

Interval

9 GRANVILLE MARKET J32 · 3/4L

Elinor M Vandegrift: A Second Book of Graded Scottish Country Dances · Crib: E-cribs · Diagram: Keith Rose's Diagrams

- 1- 1c+2c RHA, LHA
- 9- 1c cross RH | cast (2c up) ; ½ Fig8 up to face 1cnr
- 17- 1c turn 1cnr RH | pass Rsh ; turn 2cnr RH | pass Rsh to (2,1,3)
- 25- Circle6 and back

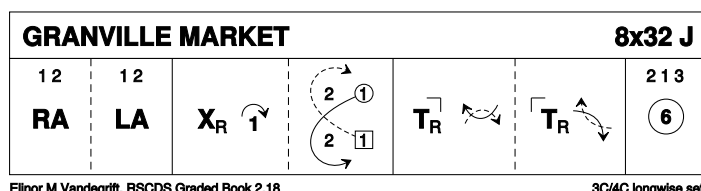

10 CURRIE MOUNTAIN R32 · 3/4L

Mary Pugh: New Brunswick Collection · Crib: E-cribs · Diagram: Keith Rose's Diagrams

- 1- 1c cross RH, cast off one (2c up) ; ½ Fig8 up round 2c (2,1,3)
- 9- 1c (start inwards) turn 3C EH ; 1c turn 2C EH (2,1,3)
- 17- 1c+3c RHA ; 1c+2c LHA
- 25- 2c+1c+3c Reels3 on the sides, 1c giving Rsh to 3c (2,1,3)

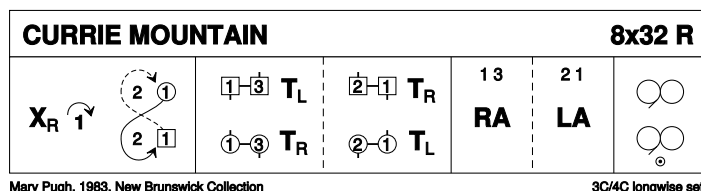

After the second turn the dancing couple continues the reel with bottom couple to change places.

11 TRIPLE HAPPINESS S32 · 3/3L

Yoshiki Oyama: RSCDS LII 10 · Crib: E-cribs · Diagram: Keith Rose's Diagrams

- 1- 1c A&R{1+1} taking (or shaking) RH briefly | turn LH ½ facing down ; cross LH between 2c and cast up to 1pl
- 9- 1c+2c The Knot, 1c finish facing 1cnrs (2,1,3)
- 17- Corners Pass and Turn BH (2,1,3)
- 25- All chase clw ½ ; turn BH ½, face each other | cast R to exchanged places (3,1,2)

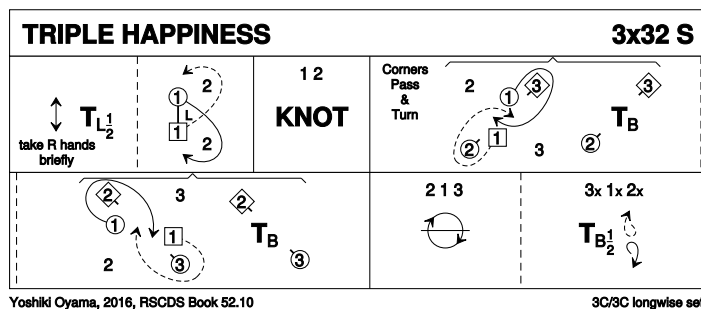

12 THE WAGGLE O' THE KILT J40 · 3/4L

James B Cosh: Twenty Two SCD · Crib: E-cribs · Diagram: Keith Rose's Diagrams

- 1- 1c cast off, lead through 3c (2c up), cast up, turn LH
- 9- 1M+2M+3M & 1W+2W+3W RHA (1c pass Rsh) ; 1W+2M+3M & 1M+2W+3W RHA (same hand!), 1c finish facing 1cnr
- 17- 1c ½Reel4 with 1cnrs, pass Lsh, ½Reel4 with 2cnrs and face 3cnr
- 25- 1c turn 3cnrs (1cnr person) RH ½, corners turn LH 1½ (or ½) ; 1c turn cnr RH ½, 1c turn LH to face 4cnr (2cnr person)
- 33- Repeat with 2cnr persons, 1c finish the LH turn (2,1,3).

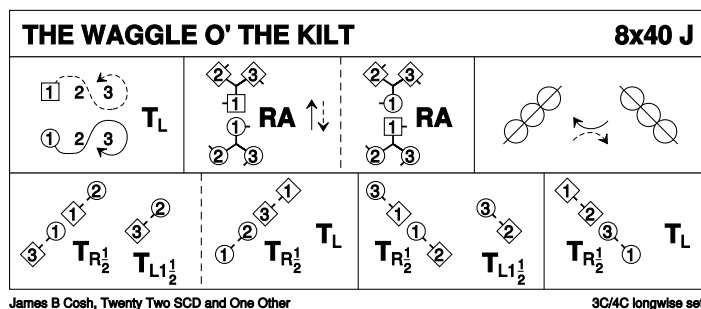

Note: on [13], the description says "change places", so 1c could also make a fast ½ LH turn into the other wheel)

13 AILEEN'S REEL R32 · 3/4L

Roy Goldring: 14 Social Dances for 2000 · Crib: E-cribs · Diagram: Keith Rose's Diagrams

- 1- 1c cross RH, 1W to sideline, 1M staying just inside, and face M side | turn 2c LH ½ ; 1c (1M leading) cast up and dance down the middle into lines across facing down (2c+1W & 3c+1M)
- 9- In lines dance down ; all pivot R and dance up
- 17- 1c (1W leading) dance up and cast L into (2,1,3) ; 1c turn LH 1¼ to finish 1M below 1W
- 25- Teapots R ; Teapots L (RHA with end couple, LHA with other end couple) (2,1,3)

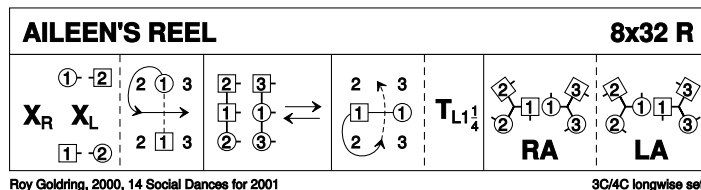

14 THE SILVER CITY S32 · 3/4L

John Drewry: Silver City Book of SCD · Crib: MiniCrib · Diagram: Keith Rose's Diagrams

- 1-8 1s cross down to dance reflection reels of 3 on opposite sides
- 9-16 1s in prom hold dance reel of 3 across with 2s giving RSh to 2M, 2s dance into 1st place as 1s turn LH to face 1st corners
- 17-24 1s turn 1st corner RH, turn partner LH, turn 2nd corner RH, 1/2 turn partner LH to end 1L facing 2s & 1M facing 3s
- 25-32 1s dance RH across (Lady with 2s & Man with 3s), pass RSh & dance LH across with other couple

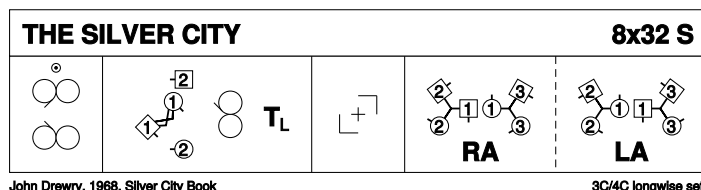

15 QUARRIES' JIG J32 · 3/4L

Kent W Smith: RSCDS XXXVI 3 · Crib: E-cribs · Diagram: Keith Rose's Diagrams

- 1- 1c set | cast (2c up) ; ½ Fig8 Lsh round 1cnr (2,1x,3)
- 9- 1M+2c and 1W+3c Lsh Reels3 across, at end 1c LH turn to face 1cnrs
- 17- 1c+1cnrs change places RH **while{2}** 2cnrs set | centre dancers change places LH **while{2}** the others chase clw one position ; repeat from new positions
- 25- Repeat from new positions, but to finish 1c turn LH to 2plx ; 2c+1c+3c set | 1c cross RH.

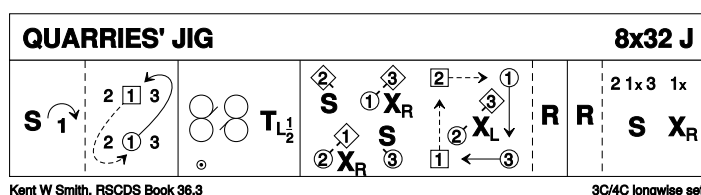

16 MAIRI'S WEDDING R40 · 3/4L

James B Cosh: Twenty Two SCD · Crib: E-cribs · Diagram: Keith Rose's Diagrams

- 1- 1c turn RH | cast (2c up) ; turn LH to face 1cnrs
- 9- 1c ½Reel4 with 1cnrs (pass P Lsh) ; Repeat with 2cnrs
- 17- Repeat with 3cnrs (1cnr person) ; Repeat with 4cnrs (2cnr person)
- 25- 1W+2c & 1M+3c Reels3 across, Lsh to 1cnr
- 33- 2c+1c+3c circle6 and back

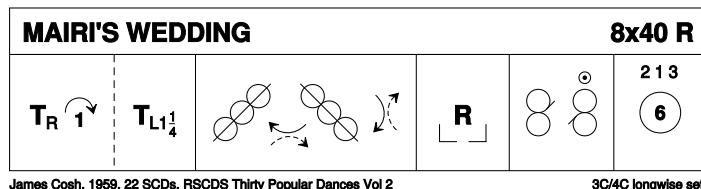

Note: Cosh explicitly tells 1c to pass Lsh in [9-24]; however the Rsh pass is quite common, and sometimes nicknamed "Mairi's Divorce".

E1 ? INCHMICKERY J32 · 5/5L

Roy Goldring: RSCDS LIII 23 · Crib: E-cribs · Diagram: Keith Rose's Diagrams

- 1- 1c+2c circle4 L ; 1c long cast to 3pl (2c+3c up) (2,3,1,4,5)
- 9- Teapots R ; and L (1c RHA with C on R ; LHA with C on L)
- 17- 1M+5W & 1W+2M Turn RH to places ; 1M+2W & 1W+5M repeat LH
- 25- 1c long cast to 5pl (4c+5c up) ; 5c+1c circle4 R (2,3,4,5,1)

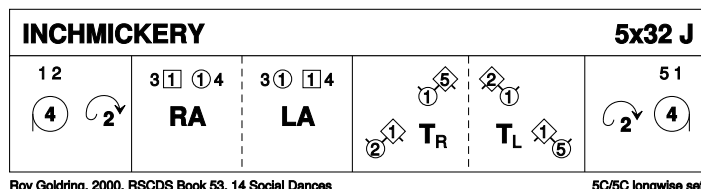

E2 [?] THE CASTLE OF MEY R32 · 3/4L

John Walton: QE Diamond Jubilee Dances · Crib: E-cribs · Diagram: Keith Rose's Diagrams

- 1- Inveran Reels 3 on the sides, 1c crossing down to start (1,2,3)
- 9- 1c+2c DblFig8, 1c cross down to start
- 17- 1c lead down the middle and up, finishing for
- 25- 1c+2c Poussette

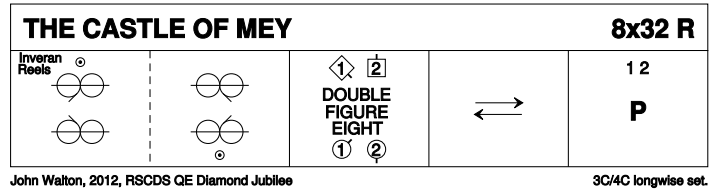

E3 [?] THE SWAN AND THE TAY S32 · 3/3L

Audrey Saunders: Scottish Country Dances for Perth 800 · Crib: E-cribs · Diagram: Keith Rose's Diagrams

- 1- 1c (in and down) Fig8 on own sides (give hands) (1,2,3)
- 9- 1c cross into Reels3{6} on opp. sides | 2c dance up as 1c face 1cnr
- 17- 1c+cnrs Pass&Turn, pass Rsh ; repeat with 2cnr, finish (2,1,3)
- 25- All set | cross RH ; chase 1/2 clw to (3,1,2)

